



# Table Of Contents

## Inhaltsverzeichnis

**VIGOUR<sup>®</sup>**

**Wir bieten Lösungen für Ihre Ideen!**  
**We offer solutions regarding your ideas!**

**Regulator Selection Guide**  
*Leitfaden für die Auswahl der Regulierungsbehörden*

**Cylinder Pressure Regulators**  
*Flaschendruckminderer*

**Dual Stage Regulators**  
*Zweistufige Druckminderer*

**Panel & Line Regulators**  
*Leitungs- & Paneldruckminderer*

**Back Pressure Regulators**  
*Leitungs- & Paneldruckminderer*

**Calibration Gas Regulators**  
*Regler fuer Kalibriergase*

**High pressure self-venting Regulator**  
*Druckminderer selbstentlüftend*

**Manifold & Hydrogen Regulators**  
*Vielfältige Regulatoren*

**Pressure Control Panels**  
*Entspannungsstationen*

**Generator Back-up Panel**  
*Generator-Absicherungspanel*

**Tapping points**  
*Entnahmestellen*

**Extensions & Mounting Station**  
*Erweiterungspanele & Flaschenanschlusspanel*

**Purge Assemblies**  
*Spüleinheiten*

**Diaphragm Valves / Needle Valves / Check Valves / Relief Valves**  
*Membranventile / Kugelhähne / Nadelventile / Rückschlagventile / Abblaseventil*

**Alarm Systems**  
*Signalgeber*

**Accessories**  
*Zubehör*

**Quick Connectors & Cylinder Connections**  
*Schnellsteckverbinder & Flaschenanschlüsse*

**Tube Fittings**  
*Zweiklemmring Verschraubung*

**Conversion Factor & Material Compatibility**  
*Umrechnungstabellen*

**Cross-section Drawing**  
*Querschnitt*

SERIES	Diaphragm regulator	Piston regulator	Dual stage regulator	Pressure control panel	Double-sided pressure control panels	Wall-mounting generator backup panel	Calibration regulator	Back pressure regulator	Max inlet pressure (bar)	Pressure control range.												
										0 to ....												
										psi	15	30	60	120	145	300			450	500		
bar	1	2	4	8	10	20	V2	V10	30	35												
<b>Cylinder Pressure Regulator</b>																						
VSR-1EM	✓								250bar			✓	✓									
VSR-1E	✓								300bar			✓	✓		✓	✓						
VSR-2E	✓	✓*											✓	✓								✓
VSR-3	✓	✓*											✓	✓								✓
VSR-6E		✓																				
VSR-11E			✓										✓	✓								
VSR-11EHP			✓																			
<b>Panel&amp;Line Regulator</b>																						
VSR-1ML/1MP	✓								100bar			✓	✓		✓	✓						
VSR-1EL/1EP	✓												✓	✓								
VSR-2EL/2EP	✓	✓*											✓	✓								✓
VSR-3L/3P	✓	✓*											✓	✓								✓
VSR-4L	✓								35bar			✓	✓		✓	✓						
VSR-6EL/6EP		✓							300bar													
VSR-12L/12HL	✓								35bar	✓	✓		✓	✓								
VSR-3PH	✓								40bar			✓	✓		✓	✓						
VSR-3F	✓								40bar			✓	✓		✓	✓	✓	✓				
VSR-4PH	✓								35bar			✓	✓		✓	✓						
VSR-4F	✓											✓	✓		✓	✓						
<b>Back Pressure Regulator</b>																						
VSR-51								✓	17bar													
VSR-52								✓	50bar													
VSR-53								✓	300bar													
<b>Calibration Gas Regulator</b>																						
VSR-15							✓		200bar			✓	✓									
VSR-19							✓															
<b>High Pressure Self-venting Regulator</b>																						
VSR-7		✓							300bar						✓						✓	
VSR-8		✓							400bar/700bar												✓	
<b>Manifold Regulator</b>																						
VSR-36		✓							300bar						✓							
<b>Hydrogen Pressure Regulator</b>																						
VSR-9		✓*										✓	✓	✓						✓		
<b>Pressure Control Panel</b>																						
VSP-1E				✓					300bar			✓	✓		✓	✓						
VSP-1				✓									✓	✓		✓	✓					✓
VSP-2E				✓									✓	✓		✓	✓					
VSP-2				✓									✓	✓		✓	✓					✓
VSP-3AE				✓									✓	✓		✓	✓					
VSP-6A				✓									✓	✓		✓	✓					✓
VSP-8AE				✓									✓	✓		✓	✓					
VSP-11E				✓									✓	✓		✓	✓					
VSP-36					✓											✓	✓					
VSP-5A				✓								✓	✓		✓	✓					✓	
<b>Generator Back-up Panel</b>																						
VSP-B						✓			300bar						✓							
<b>Tapping Points</b>																						
VSR-1ET	✓								100bar			✓	✓		✓	✓						
VSR-2T	✓												✓	✓		✓	✓					✓
VSR-1ETG	✓												✓	✓		✓	✓					
VSR-2TG	✓												✓	✓		✓	✓					✓
VSR-3T	✓								60bar			✓	✓			✓						
VSR-3TG	✓												✓	✓		✓	✓					
VSR-4T	✓												✓	✓		✓	✓					
VSR-5T	✓												✓	✓		✓	✓					

\*: Outlet Pressure more than 20bar

psig (bar)								Cv															Page	SERIES				
600	750	900	1500	3000	4500	6000		0.06	0.07	0.08	0.1	0.12	0.14	0.15	0.18	0.28	0.46	0.5	0.8	1	1.7	2			3.1	5.1		
<b>Cylinder Pressure Regulator</b>																												
								✓																			1	VSR-1EM
									✓																		3	VSR-1E
	✓									✓																	5	VSR-2E
	✓										✓											✓					7	VSR-3
✓			✓	✓	✓									✓													9	VSR-6E
									✓																		11	VSR-11E
	✓		✓	✓										✓													13	VSR-11EHP
<b>Panel&amp;Line Regulator</b>																												
												✓															15	VSR-1ML/1MP
															✓												17	VSR-1EL/1EP
	✓															✓											19	VSR-2EL/2EP
	✓																				✓						21	VSR-3L/3P
																								✓			23	VSR-4L
	✓		✓	✓										✓													25	VSR-6EL/6EP
																							✓				27	VSR-12L/12HL
																					✓						29	VSR-3PH
																					✓						33	VSR-3F
																						✓					31	VSR-4PH
																							✓			35	VSR-4F	
<b>Back Pressure Regulator</b>																												
										✓																	37	VSR-51
											✓																39	VSR-52
											✓		✓														41	VSR-53
<b>Calibration Gas Regulator</b>																												
																											43	VSR-15
																											44	VSR-19
<b>High Pressure Self-venting Regulator</b>																												
	✓		✓																		✓						45	VSR-7
	✓		✓	✓	✓	✓	✓																				47	VSR-8
<b>Manifold Regulator</b>																												
✓		✓																						✓			49	VSR-36
<b>Hydrogen Pressure Regulator</b>																												
																					✓						51	VSR-9
<b>Pressure Control Panel</b>																												
	✓		✓	✓					✓																		53	VSP-1E
	✓									✓																	55	VSP-1
	✓		✓	✓					✓																		57	VSP-2E
	✓									✓																	59	VSP-2
	✓		✓							✓																	61	VSP-3AE
	✓																				✓						63	VSP-6A
	✓		✓							✓																	65	VSP-8AE
											✓																67	VSP-11E
✓		✓																									69	VSP-36
	✓									✓																	71	VSP-5A
<b>Generator Back-up Panel</b>																												
										✓																	73	VSP-B
<b>Tapping Points</b>																												
	✓								✓																		75	VSR-1ET
	✓									✓						✓											77	VSR-2T
	✓										✓																79	VSR-1ETG
	✓											✓					✓										81	VSR-2TG
													✓														83	VSR-3T
													✓														85	VSR-3TG
													✓														87	VSR-4T
									✓																		89	VSR-5T

# Cylinder Pressure Regulators / Flaschendruckminderer

## VSR-1EM Series

### Product Features

- Cylinder pressure regulator with lightweight materials
- Brass chrome plated or aluminium body and aluminium bonnet for inert, reactive, flammable and oxidizing gas and mixtures up to grade 6.0
- Stainless steel 316L body and aluminium bonnet for corrosive gases
- Accurate and stable pressure control
- Minimal internal volume allows for rapid purging and carry-over
- Various porting configurations are available
- Tested for use with oxygen



### Typical Applications

- Analyzers
- Lecture bottles
- Sampling systems

### Technical Data

Type:	single-stage
Inlet pressure P <sub>1</sub> :	max. 250 bar
Outlet pressure P <sub>2</sub> :	2/4/10 bar
Materials	
Body regulator:	see ordering info
Valve seat:	PCTFE
Diaphragm:	Hastelloy® C276
O-ring: (option)	Viton® (FKM) Kalrez® (FFKM)
Filter:	SS 316L
Inlets and Outlets:	1/8", 1/4" NPT
Temperature range:	-30°C to +74°C
Leak rate (to atmosphere) (via seat)	1x10 <sup>-6</sup> m bar l/s He Bubble-tight
Flow capacity:	C <sub>v</sub> = 0.06
Weight:	0.47 kg

### Dimensions (mm)

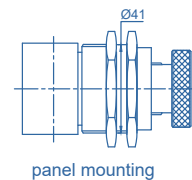
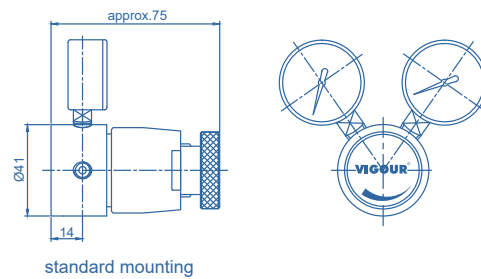

### Flow Chart

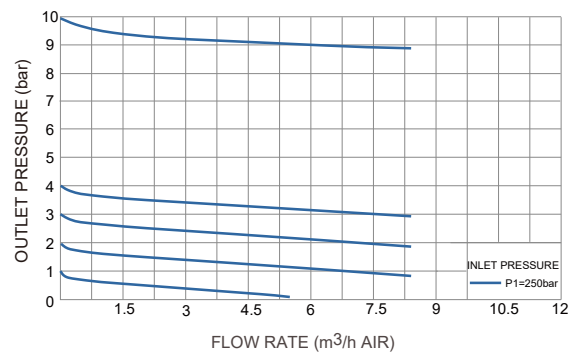
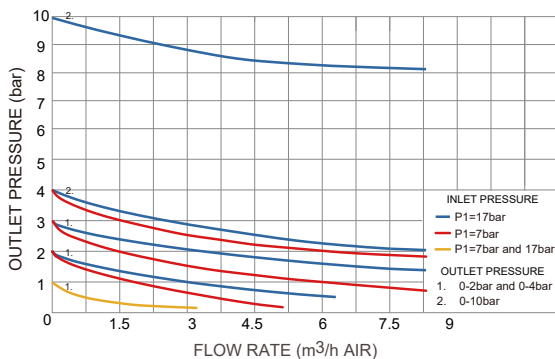

# Flaschendruckminderer / Cylinder Pressure Regulators VSR-1EM Series

## Ordering Information

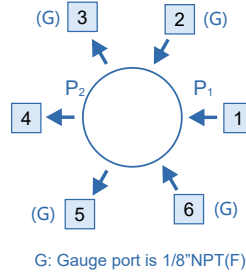

### Inlets / Outlets

DIN: Germany	NF: French	02: 1/8" Tube fitting	TW6M: 6mm Weld tube
CGA: USA	JIS: Japan	04: 1/4" Tube fitting	TW8M: 8mm Weld tube
BSP: British	F2: 1/8"NPT(F)	06: 3/8" Tube fitting	P: Gauge(Psig/bar)
GB: China	F4: 1/4"NPT(F)	6M: 6mm Tube fitting	R: Relief valve
UNI: Italy	M4: 1/4"NPT(M)	8M: 8mm Tube fitting	B: Plug

\* Other connection standard, consult factory.

### Port Selection

VSR - 1EMP S - 250 - 10 - 1 - 2 - 3 - 4 - 5 - 6 - N<sub>2</sub>

#### Mounting

- None: Standard mounting
- P: Panel mounting

#### Body Material

- S: 316L
- C: Chrome plated brass
- A: Aluminum

#### Inlet Pressure P<sub>1</sub>

250: 250 bar

#### Type of Gas

Please specify type of gas

#### Outlet Pressure P<sub>2</sub>

- 2: to 2 bar
- 4: to 4 bar
- 10: to 10 bar

## Ordering Example

Example: VSR - 1EMS - 250 - 10 - F4 - P - P - F4 - B - B - O<sub>2</sub>

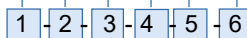

\* For mixed gases, please specify cylinder connection standard and thread when ordering.

# Cylinder Pressure Regulators / Flaschendruckminderer

## VSR-1E Series

### Product Features

- Cylinder pressure regulator
- Brass chrome plated body and bonnet for inert, reactive, flammable and oxidizing gas and mixtures up to grade 6.0
- Stainless steel 316L body and bonnet for corrosive gases
- 6 ports flexible configuration
- Stable outlet pressure
- Simple outlet pressure limitation by handwheel
- Tested for use with oxygen

### Typical Applications

- Component Testing
- Calibration Systems
- Laboratory Pressure Control
- High Pressure Sampling Systems
- Service & Test Equipment



### Dimensions (mm)

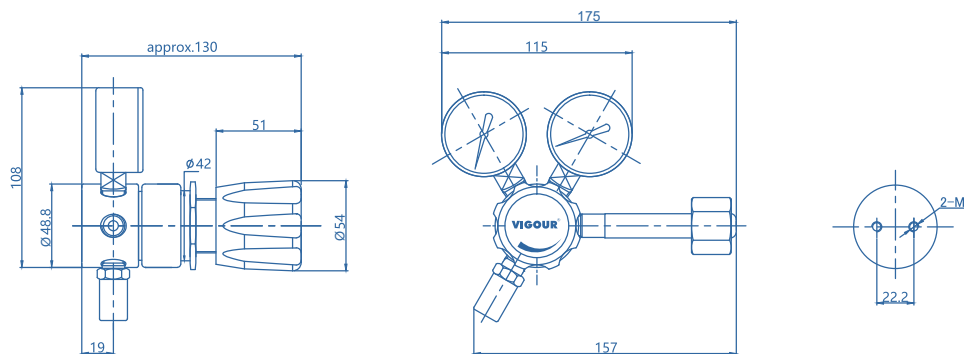

### Technical Data

Type:	single-stage
Inlet pressure P <sub>1</sub> :	max. 300 bar
Outlet pressure P <sub>2</sub> :	2/4/10/20 bar
Materials	
Body regulator, relief valve:	see ordering info
Valve seat:	PCTFE
Diaphragm:	Hastelloy® C276
O-ring:	Viton® (FKM)
(option)	Kalrez® (FFKM)
Filter:	SS 316L
Inlets and Outlets:	1/4" NPT(F)
Temperature range:	-30°C to +74°C
Leak rate (to atmosphere)	1x10 <sup>-8</sup> mbar l/s He
(via seat)	1x10 <sup>-6</sup> mbar l/s He
Flow capacity:	C <sub>v</sub> =0.07
Weight:	1.30 kg

### Flow Chart

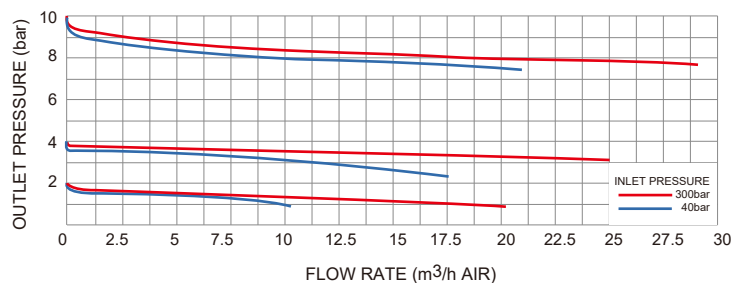

# Flaschendruckminderer / Cylinder Pressure Regulators

## VSR-1E Series

### Ordering Information



#### Inlets / Outlets

DIN: Germany  
CGA: USA  
BSP: British  
GB: China  
UNI: Italy

NF: French  
JIS: Japan  
F4: 1/4"NPT(F)  
M4: 1/4"NPT(M)  
O2: 1/8" Tube fitting

04: 1/4" Tube fitting  
06: 3/8" Tube fitting  
6M: 6mm Tube fitting  
8M: 8mm Tube fitting  
TW6M: 6mm Weld tube

TW8M: 8mm Weld tube  
P: Gauge(Psig/bar)  
R: Relief valve  
B: Plug

\* Other connection standard, consult factory.

#### Port Selection

VSR - 1EPS - 200 - 20 - 1 - 2 - 3 - 4 - 5 - 6 - N<sub>2</sub>

#### Type

None: Standard mounting  
P: Panel mounting

#### Body Material

S: 316L  
C: Chrome Plated Brass

#### Inlet Pressure P<sub>1</sub>

40: 40 bar  
100: 100 bar  
200: 200 bar  
300: 300 bar

#### Outlet Pressure P<sub>2</sub>

2: to 2 bar  
4: to 4 bar  
10: to 10 bar  
20: to 20 bar

#### Type of Gas

Please specify type of gas

### Ordering Example

Example: VSR - 1EC - 200 - 10 - CGA - P - P - F4 - B - B - O<sub>2</sub>

1 - 2 - 3 - 4 - 5 - 6



\* For mixed gases, please specify cylinder connection standard and thread when ordering.



# Cylinder Pressure Regulators / Flaschendruckminderer

## VSR-2E Series

### Product Features

- Cylinder pressure regulator
- Brass chrome plated body for inert, reactive, flammable and oxidizing gas and mixtures up to grade 6.0
- Stainless steel 316L body for corrosive gases
- 6 ports flexible configuration
- Stable outlet pressure
- Simple outlet pressure limitation by handwheel
- Inlet filter
- Tested for use with oxygen

### Typical Applications

- Component Testing
- Calibration Systems
- Laboratory Pressure Control
- High Pressure Sampling Systems
- Service & Test Equipment

### Dimensions (mm)

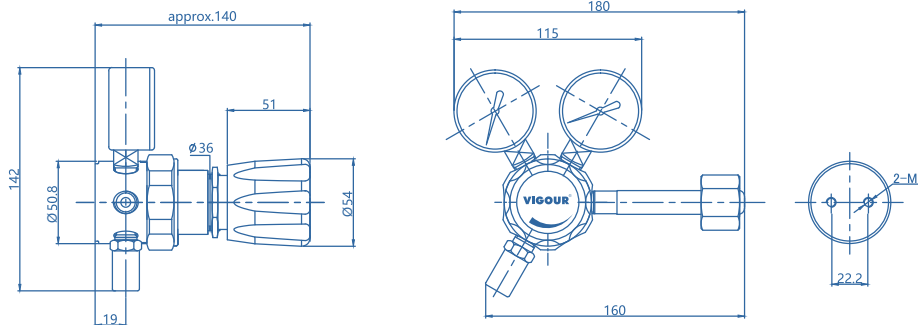

### Technical Data

Type:	single-stage
Inlet pressure P <sub>1</sub> :	max. 300bar
Outlet pressure P <sub>2</sub> :	-1bar / 2/4/10/20/ 35/50bar
Materials	
Body regulator, relief valve:	see ordering info
Valve seat:	PCTFE
Diaphragm:	Hastelloy® C276
Filter:	SS 316L
O-ring: (option)	Viton® (FKM) Kalrez® (FFKM)
Inlets and Outlets:	1/4" NPT(F)
Temperature range:	-30°C to +74°C
Leak rate (to atmosphere) (via seat)	1x10 <sup>-8</sup> mbar l/s He 1x10 <sup>-6</sup> mbar l/s He
Flow capacity:	Cv=0.08
Weight:	1.25 kg

### Flow Chart

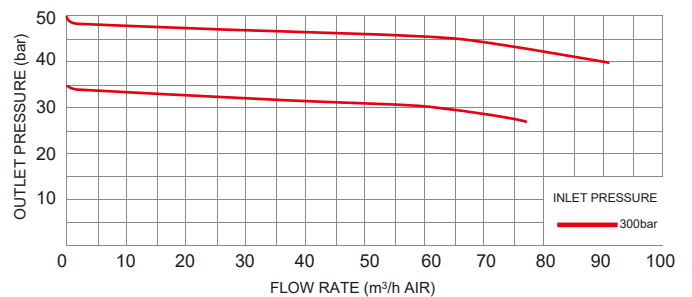
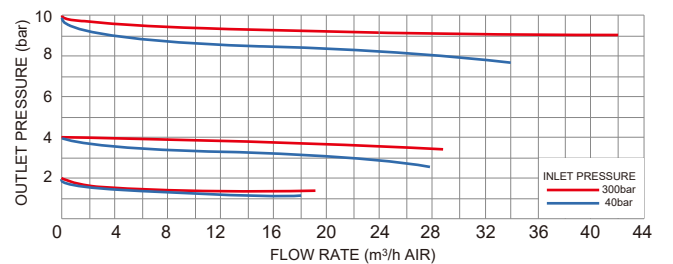

# Flaschendruckminderer / Cylinder Pressure Regulators

## VSR-2E Series

### Ordering Information:

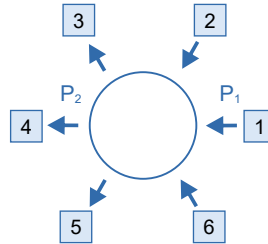

#### Inlets / Outlets

DIN: Germany	NF: French	04: 1/4" Tube fitting	TW8M: 8mm Weld tube
CGA: USA	JIS: Japan	06: 3/8" Tube fitting	P: Gauge(Psig/bar)
BSP: British	F4: 1/4"NPT(F)	6M: 6mm Tube fitting	R: Relief valve
GB: China	M4: 1/4"NPT(M)	8M: 8mm Tube fitting	B: Plug
UNI: Italy	O2: 1/8" Tube fitting	TW6M: 6mm Weld tube	

\* Other connection standard, consult factory.

#### Port Selection

VSR - 2EPS - 200 - 20 - 1 - 2 - 3 - 4 - 5 - 6 - N2

#### Type

None: Standard mounting  
P: Panel mounting

#### Body Material

S: 316L  
C: Chrome Plated Brass

#### Inlet Pressure P<sub>1</sub>

40: 40 bar  
100: 100 bar  
200: 200 bar  
300: 300 bar

#### Outlet Pressure P<sub>2</sub>

2: to 2 bar  
4: to 4 bar  
10: to 10 bar  
20: to 20 bar  
35: to 35 bar  
50: to 50 bar  
V2: -1bar to 2 bar  
V4: -1bar to 4 bar  
V10: -1bar to 10 bar  
V20: -1bar to 20 bar

#### Type of Gas

Please specify type of gas

### Ordering Example

Example: VSR - 2EC - 200 - 10 - CGA - P - P - F4 - B - B - O<sub>2</sub>

1 - 2 - 3 - 4 - 5 - 6



\* For mixed gases, please specify cylinder connection standard and thread when ordering.

# Cylinder Pressure Regulators / Flaschendruckminderer

## VSR-3 Series

### Product Features

- Pressure regulator, special design for manifold application
- Brass chrome plated body for inert, reactive, flammable and oxidizing gas and mixtures up to grade 6.0
- Stainless steel 316L body and chromed brass bonnet for corrosive gases
- 6 ports flexible configuration
- Stable outlet pressure
- Simple outlet pressure limitation by handwheel
- Inlet filter
- Tested for use with oxygen

### Typical Applications

- Component Testing
- Calibration Systems
- Laboratory Pressure Control
- High Pressure Sampling Systems
- Service & Test Equipment

### Dimensions (mm)

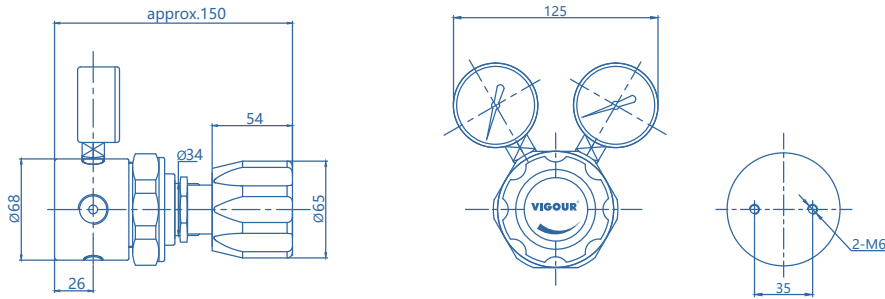

### Technical Data

Type:	single-stage
Inlet pressure P <sub>1</sub> :	max. 300bar
Outlet pressure P <sub>2</sub> :	2/4/10/20/35/50bar
Materials	
Body regulator, relief valve:	see ordering info
Valve seat:	PCTFE
Diaphragm:	Hastelloy® C276
Filter:	SS 316L
O-ring:	Viton® (FKM)
(option)	Kalrez® (FFKM)
Inlets and Outlets:	see ordering info
Temperature range:	-30°C to +74°C
Leak rate (to atmosphere)	1x10 <sup>-8</sup> mbar l/s He
(via seat)	1x10 <sup>-6</sup> mbar l/s He
Flow capacity:	C <sub>v</sub> =1.0
Weight:	2.7kg

### Flow Chart

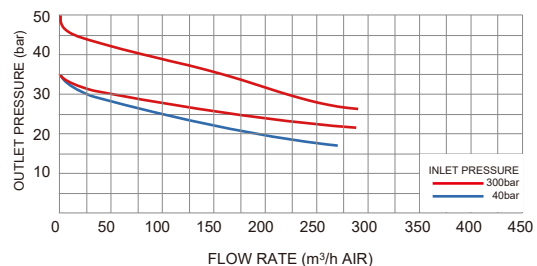
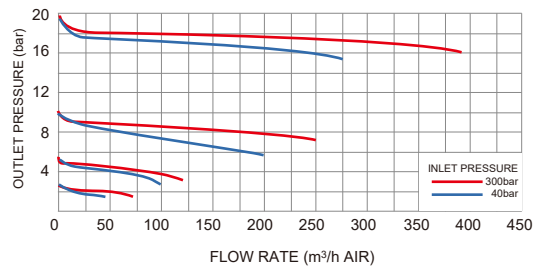

# Flaschendruckminderer / Cylinder Pressure Regulators VSR-3 Series

## Ordering Information

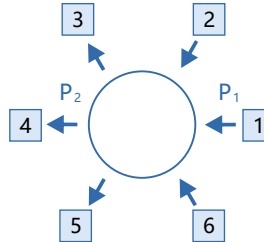

### Inlets / Outlets

F4: 1/4"NPT(F)	TW12M: 12mm Weld tube
F6: 3/8"NPT(F)	TW20M: 20mm Weld tube
F8: 1/2"NPT(F)	P: Gauge(Psig/bar)
F12: 3/4"NPT(F)	B: Plug

\* Other connection standard, consult factory.

### Port Selection

VSR - 3PS - 200 - 20 - 1 - 2 - 3 - 4 - 5 - 6 - N2

**Type**  
None: Standard mounting  
P: Panel mounting

**Body Material**  
S: 316L  
C: Chrome Plated Brass

**Inlet Pressure P<sub>1</sub>**  
40: 40 bar  
100: 100 bar  
200: 200 bar  
300: 300 bar

**Outlet Pressure P<sub>2</sub>**  
2: to 2 bar  
4: to 4 bar  
10: to 10 bar  
20: to 20 bar  
35: to 35 bar  
50: to 50 bar

**Type of Gas**

Please specify type of gas

## Ordering Example

**Example: VSR - 3S - 200 - 20 - F8 - P - P - F8 - B - B - N2**

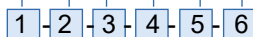

\* For mixed gases, please specify cylinder connection standard and thread when ordering.

# Cylinder Pressure Regulators / Flaschendruckminderer

## VSR-6E Series

### Product Features

- Diaphragm design high pressure piston regulator
- Brass chrome plated body and bonnet for inert, reactive, flammable and oxidizing gas and mixtures up to grade 6.0
- Stainless steel 316L body and bonnet for corrosive gases
- 6 ports flexible configuration
- Stable outlet pressure
- Simple outlet pressure limitation by handwheel
- Inlet filter
- Tested for use with oxygen

### Typical Applications

- Component Testing
- Calibration Systems
- Laboratory Pressure Control
- High Pressure Sampling Systems
- Service & Test Equipment

### Dimensions (mm)

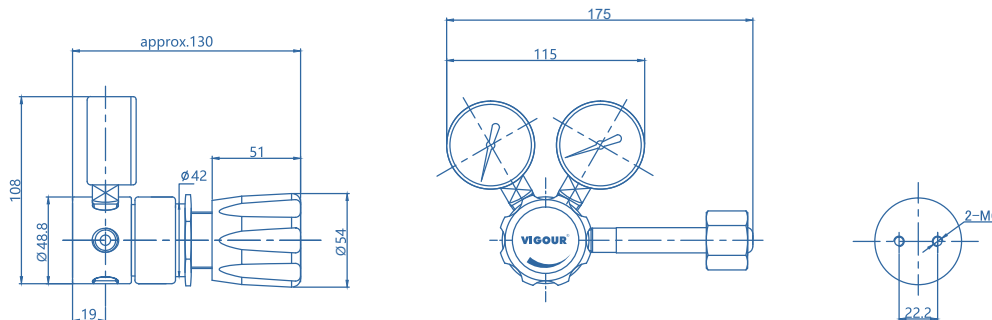

### Technical Data

Type:	single-stage
Inlet pressure P <sub>1</sub> :	max. 300bar
Outlet pressure P <sub>2</sub> :	50/100/200bar
Materials	
Body regulator:	see ordering info
Bonnet:	chrome plated brass
Valve seat:	PCTFE
Diaphragm:	Hastelloy <sup>®</sup> C276
O-ring: (option)	Viton <sup>®</sup> (FKM) Kalrez <sup>®</sup> (FFKM)
Filter:	SS 316L
Inlets and Outlets:	1/4" NPT (F)
Temperature range:	-30°C to +74°C
Leak rate (to atmosphere) (via seat)	1x10 <sup>-8</sup> mbar l/s He 1x10 <sup>-6</sup> mbar l/s He
Flow capacity:	Cv =0.15
Weight:	1.20 kg

### Flow Chart

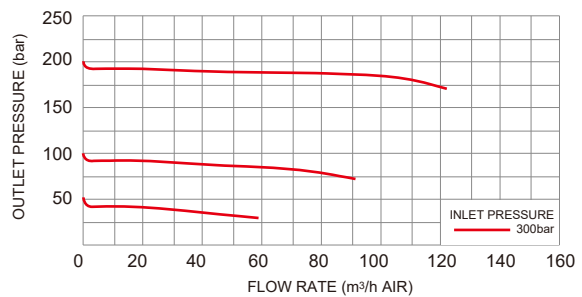

# Flaschendruckminderer/ Cylinder Pressure Regulators VSR-6E Series

## Ordering Information

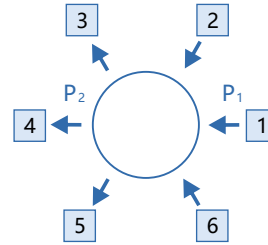

### Inlets / Outlets

DIN: Germany  
CGA: USA  
BSP: British  
GB: China  
UNI: Italy

NF: French  
JIS: Japan  
F4: 1/4"NPT(F)  
M4: 1/4"NPT(M)  
O2: 1/8" Tube fitting

O4: 1/4" Tube fitting  
O6: 3/8" Tube fitting  
6M: 6mm Tube fitting  
8M: 8mm Tube fitting

TW6M: 6mm Weld tube  
TW8M: 8mm Weld tube  
P: Gauge(Psig/bar)  
B: Plug

\* Other connection standard, consult factory.

### Port Selection

VSR - 6EPS - 300 - 100 - 1 - 2 - 3 - 4 - 5 - 6 - N2

#### Options

None: Standard mounting  
P: Panel mounting

#### Body Material

S: 316L  
C: Chrome Plated Brass

#### Inlet Pressure P<sub>1</sub>

200: 200 bar  
300: 300 bar

#### Outlet Pressure P<sub>2</sub>

50: to 50 bar  
100: to 100 bar  
200: to 200 bar

#### Type of Gas

Please specify type of gas

## Ordering Example

Example: VSR - 6EC - 200 - 100 - CGA - P - P - F4 - B - B - O2

1 - 2 - 3 - 4 - 5 - 6



\* For mixed gases, please specify cylinder connection standard and thread when ordering.

# Dual Stage Regulators / Zweistufige Druckminderer

## VSR-11E Series

### Product Features

- Dual stage pressure regulator
- Brass chrome plated body and bonnet for inert, reactive, flammable and oxidizing gas and mixtures up to grade 6.0
- Stainless steel 316L body and bonnet for corrosive gases
- Simple outlet pressure limitation by handwheel
- Inlet filter
- Stable outlet pressure
- Tested for use with oxygen

### Typical Applications

- Component Testing
- Calibration Systems
- Laboratory Pressure Control
- High Pressure Sampling Systems
- Service & Test Equipment



### Dimensions (mm)

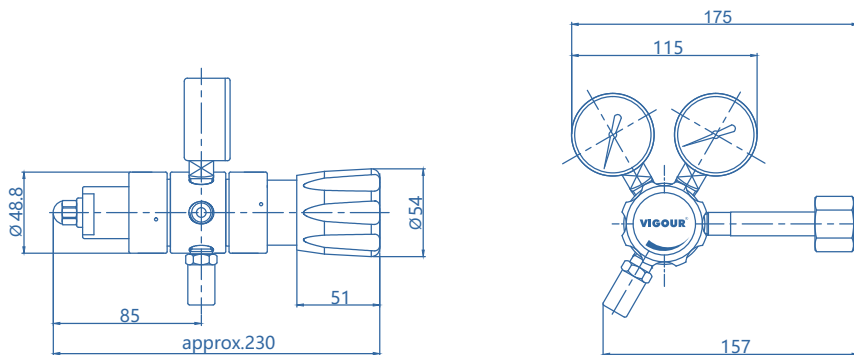

### Technical Data

Type	Dual-stage
Inlet pressure P <sub>1</sub>	max. 300 bar
Outlet pressure P <sub>2</sub>	2/4/10/20 bar
Materials	
Body regulator, relief valve:	see ordering info
Valve seat:	PCTFE
Diaphragm:	Hastelloy® C276
Filter:	SS 316L
Inlets and Outlets:	1/4" NPT(F)
Temperature range:	-30°C to +74°C
Leak rate (to atmosphere)	1x10 <sup>-8</sup> mbar l/s He
(via seat)	1x10 <sup>-6</sup> mbar l/s He
Flow capacity:	Cv=0.07
Weight:	2.10 kg

### Flow Chart

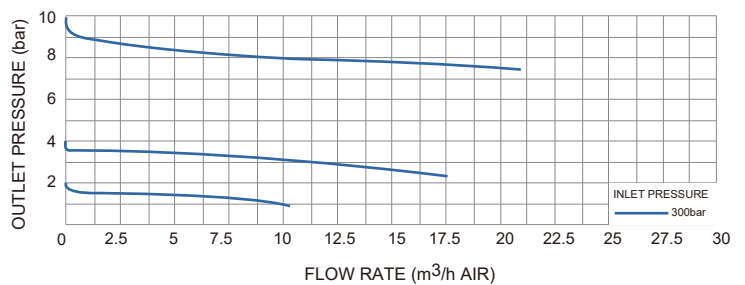

# Zweistufige Druckminderer / Dual Stage Regulators

## VSR-11E Series

### Ordering Information

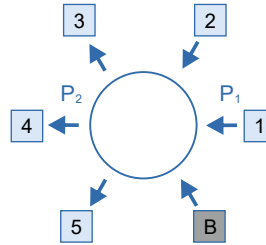

#### Inlets / Outlets

DIN: Germany	NF: French	04: 1/4" Tube fitting	R: Relief valve
CGA: USA	JIS: Japan	06: 3/8" Tube fitting	B: Plug
BSP: British	F4: 1/4"NPT(F)	6M: 6mm Tube fitting	
GB: China	M4: 1/4"NPT(M)	8M: 8mm Tube fitting	
UNI: Italy	02: 1/8" Tube fitting	P: Gauge(Psig/bar)	

\* Other connection standard, consult factory.

#### Port Selection

VSR - 11ES - 200 - 10 - 1 - 2 - 3 - 4 - 5 - B - N2

#### Body Material

- S: 316L
- C: Chrome Plated Brass

#### Inlet Pressure P<sub>1</sub>

- 100: 100 bar
- 200: 200 bar
- 300: 300 bar

#### Outlet Pressure P<sub>2</sub>

- 2: to 2 bar
- 4: to 4 bar
- 10: to 10 bar
- 20: to 20 bar

#### Type Of Gas

Please specify type of gas

### Ordering Example

Example: VSR - 11EC - 200 - 10 - F4 - P - P - F4 - B - B - N2

1 2 3 4 5 6



\* For mixed gases, please specify cylinder connection standard and thread when ordering.



# Dual Stage Regulators / Zweistufige Druckminderer

## VSR-11EHP Series

### Product Features

- Dual stage pressure regulator
- Brass chrome plated body and bonnet for inert, reactive, flammable and oxidizing gas and mixtures up to grade 6.0
- Stainless steel 316L body and bonnet for corrosive gases
- Simple outlet pressure limitation by handwheel
- Inlet filter
- Stable outlet pressure
- Tested for use with oxygen



### Typical Applications

- Component Testing
- Calibration Systems
- Laboratory Pressure Control
- High Pressure Sampling Systems
- Service & Test Equipment

### Dimensions (mm)

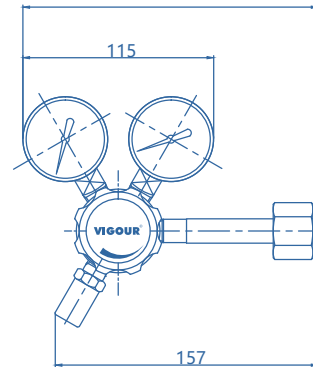
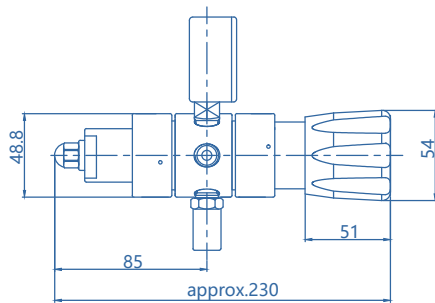

### Technical Data

Type	Dual-stage
Inlet pressure P <sub>1</sub>	max. 300 bar
Outlet pressure P <sub>2</sub>	50/100/200 bar
Materials	
Body regulator, relief valve:	see ordering info
Valve seat:	PCTFE
Diaphragm:	Hastelloy® C276
Filter:	SS 316L
Inlets and Outlets:	1/4" NPT(F)
Temperature range:	-30°C to +74°C
Leak rate (to atmosphere)	1x10 <sup>-8</sup> mbar l/s He
(via seat)	1x10 <sup>-6</sup> mbar l/s He
Flow capacity:	Cv=0.15
Weight:	2.10 kg

### Flow Chart

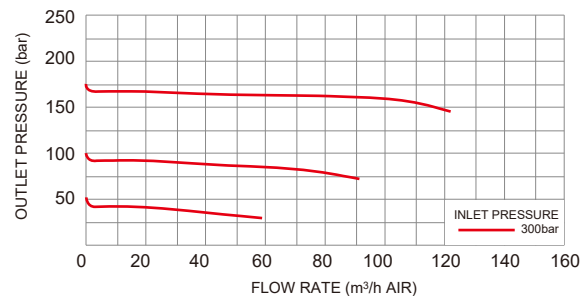

# Zweistufige Druckminderer / Dual Stage Regulators VSR-11EHP Series

## Ordering Information

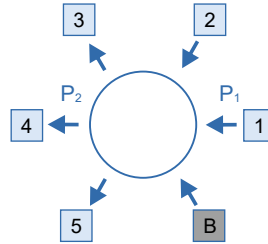

### Inlets / Outlets

DIN: Germany	NF: French	04: 1/4" Tube fitting	R: Relief valve
CGA: USA	JIS: Japan	06: 3/8" Tube fitting	B: Plug
BSP: British	F4: 1/4"NPT(F)	6M: 6mm Tube fitting	
GB: China	M4: 1/4"NPT(M)	8M: 8mm Tube fitting	
UNI: Italy	02: 1/8" Tube fitting	P: Gauge(Psig/bar)	

\* Other connection standard, consult factory.

### Port Selection

VSR - 11EHP S - 200 - 50 - 1 - 2 - 3 - 4 - 5 - B - N2

#### Body Material

- S: 316L
- C: Chrome Plated Brass

#### Inlet Pressure P<sub>1</sub>

- 100: 100 bar
- 200: 200 bar
- 300: 300 bar

#### Outlet Pressure P<sub>2</sub>

- 50: to 50 bar
- 100: to 100 bar
- 200: to 200 bar

#### Type Of Gas

Please specify type of gas

## Ordering Example

Example: VSR - 11EHP C - 200 - 50 - F4 - P - P - F4 - B - B - N<sub>2</sub>

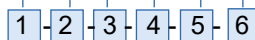

\* For mixed gases, please specify cylinder connection standard and thread when ordering.

# Mini Panel & Line Regulators / Leitungs- & Paneldruckminderer VSR-1ML & VSR-1MLP Series

## Product Features

- Line mounting pressure regulator
- Brass chrome plated body and bonnet for inert, reactive, flammable and oxidizing gas and mixtures up to grade 6.0
- Stainless steel 316L body and bonnet for corrosive gases
- 4 ports flexible configuration
- Stable outlet pressure
- Simple outlet pressure limitation by handwheel
- Tested for use with oxygen



## Typical Applications

- Component Testing
- Calibration Systems
- Laboratory Pressure Control
- High Pressure Sampling Systems
- Service & Test Equipment

VSR-1ML



VSR-1MLP



Mounting panel  
Model No.: VSR-T-BPB

## Dimensions (mm)

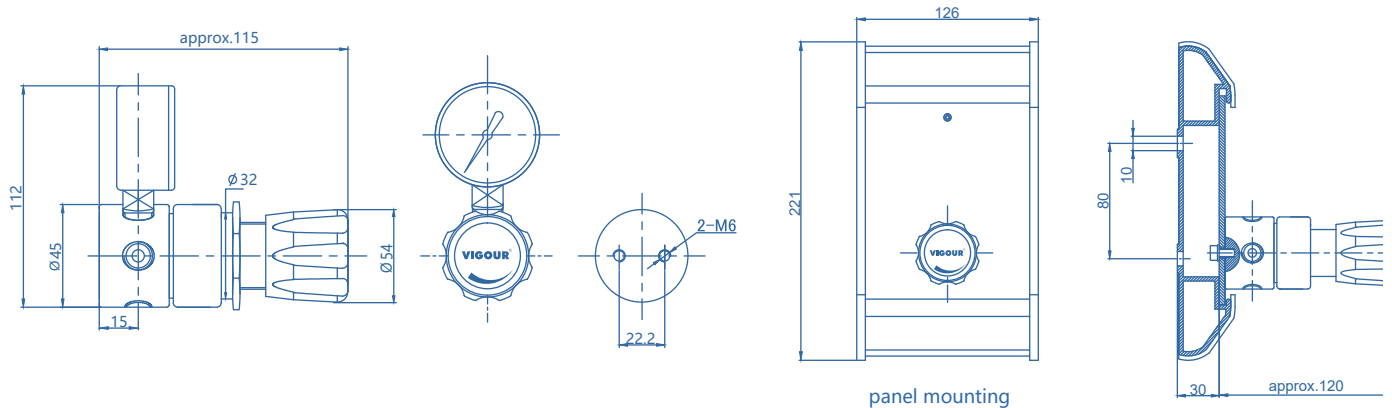

## Technical Data

Type:	single-stage
Inlet pressure P <sub>1</sub> :	max. 100 bar
Outlet pressure P <sub>2</sub> :	2/4/10/20 bar
Materials	
Body regulator	see ordering info
Valve seat:	PCTFE
Diaphragm:	Hastelloy® C276
Filter:	SS 316L
Inlets and Outlets:	1/8" NPT(F)
Temperature range:	-30°C to +74°C
Leak rate (to atmosphere) (via seat)	1x10 <sup>-8</sup> mbar l/s He 1x10 <sup>-6</sup> mbar l/s He
Flow capacity:	Cv=0.12
Weight:	0.85 kg

## Flow Chart

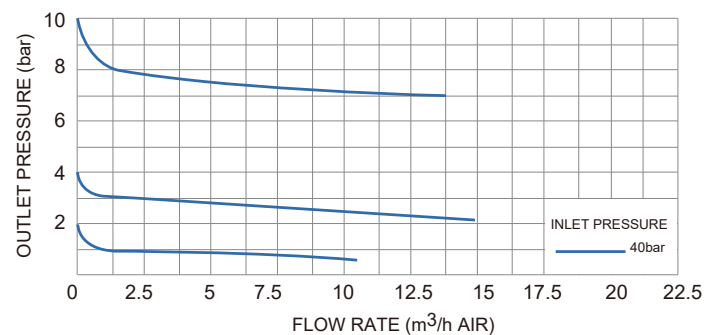

# Leitungs- & Paneldruckminderer / Mini Panel & Line Regulators VSR-1ML & VSR-1MLP Series

## Ordering Information

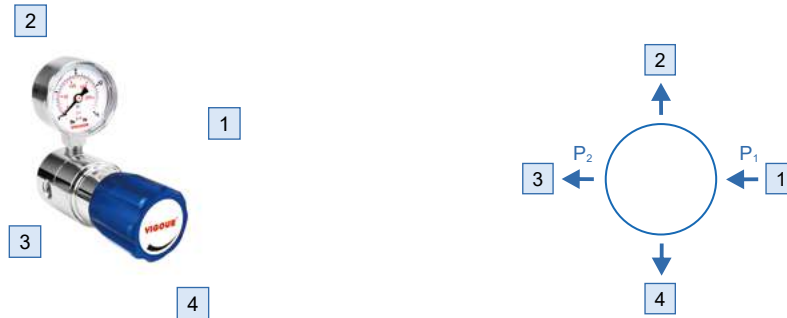

### Inlets / Outlets

F4: 1/4"NPT(F)	06: 3/8" Tube fitting	TW8M: 8mm Weld tube
M4: 1/4"NPT(M)	6M: 6mm Tube fitting	P: Gauge(Psig/bar)
02: 1/8" Tube fitting	8M: 8mm Tube fitting	B: Plug
04: 1/4" Tube fitting	TW6M: 6mm Weld tube	

\* Other connection standard, consult factory.

### Port Selection

VSR - 1ML S - 100 - 20 - 1 - 2 - 3 - 4 - N2

#### Type

L: Line  
LP: Panel

#### Body Material

S: 316L  
C: Chrome Plated Brass

#### Inlet Pressure P<sub>1</sub>

40: 40 bar  
100: 100 bar

#### Type of Gas

Please specify type of gas

#### Outlet Pressure P<sub>2</sub>

2: to 2 bar  
4: to 4 bar  
10: to 10 bar  
20: to 20 bar

## Ordering Example

Example: VSR - 1ML S - 100 - 20 - F4 - P - F4 - B - N<sub>2</sub>

1 - 2 - 3 - 4



# Panel & Line Regulators / Leitungs- & Paneldruckminderer

## VSR-1EL & VSR-1ELP Series

### Product Features

- Line mounting pressure regulator
- Brass chrome plated body and bonnet for inert, reactive, flammable and oxidizing gas and mixtures up to grade 6.0
- Stainless steel 316L body and bonnet for corrosive gases
- 4 ports flexible configuration
- Stable outlet pressure
- Simple outlet pressure limitation by handwheel
- Tested for use with oxygen



### Typical Applications

- Component Testing
- Calibration Systems
- Laboratory Pressure Control
- High Pressure Sampling Systems
- Service & Test Equipment

VSR-1EL



VSR-1ELP



Mounting panel  
Model No.: VSR-T-BPB

### Dimensions (mm)

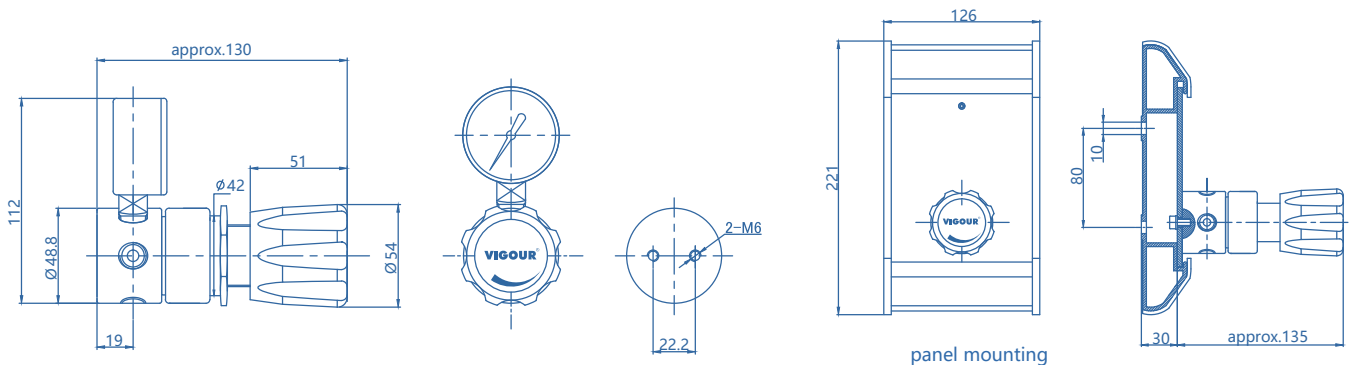

### Technical Data

Type:	single-stage
Inlet pressure P <sub>1</sub> :	max. 100 bar
Outlet pressure P <sub>2</sub> :	2/4/10/20 bar
Materials	
Body regulator	see ordering info
Valve seat:	PCTFE
Diaphragm:	Hastelloy® C276
Filter:	SS 316L
Inlets and Outlets:	1/4" NPT(F)
Temperature range:	-30°C to +74°C
Leak rate (to atmosphere)	1x10 <sup>-8</sup> mbar l/s He
(via seat)	1x10 <sup>-6</sup> mbar l/s He
Flow capacity:	C <sub>v</sub> =0.18
Weight:	1.04 kg

### Flow Chart

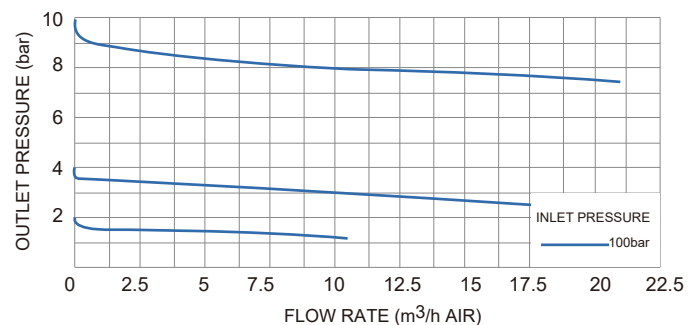

# Leitungs- & Paneldruckminderer/Panel & Line Regulators VSR-1EL & VSR-1ELP Series

## Ordering Information

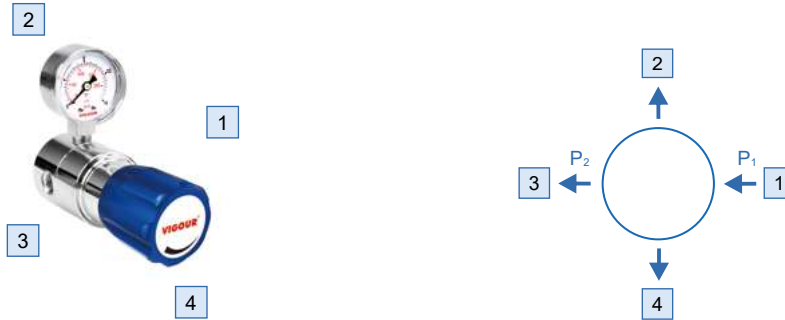

### Inlets / Outlets

F4: 1/4"NPT(F)	02: 1/8" Tube fitting	8M: 8mm Tube fitting	B: Plug
M4: 1/4"NPT(M)	04: 1/4" Tube fitting	TW6M: 6mm Weld tube	
F6: 3/8" NPT(F)	06: 3/8" Tube fitting	TW8M: 8mm Weld tube	
M6: 3/8" NPT(M)	6M: 6mm Tube fitting	P: Gauge(Psig/bar)	

\* Other connection standard, consult factory.

### Port Selection

VSR - 1EL S - 100 - 20 - 1 - 2 - 3 - 4 - N<sub>2</sub>

#### Type

L: Line  
LP: Panel

#### Body Material

S: 316L  
C: Chrome Plated Brass

#### Inlet Pressure P<sub>1</sub>

40: 40 bar  
100: 100 bar

#### Type of Gas

Please specify type of gas

#### Outlet Pressure P<sub>2</sub>

2: to 2 bar  
4: to 4 bar  
10: to 10 bar  
20: to 20 bar

## Ordering Example

Example: VSR - 1EL C - 100 - 20 - F4 - P - F4 - B - O<sub>2</sub>

1 - 2 - 3 - 4



# Panel & Line Regulators / Leitungs- & Paneldruckminderer

## VSR-2EL & VSR-2ELP Series

### Product Features

- Line and Panel mounting pressure regulator
- Brass chrome plated body for inert, reactive, flammable and oxidizing gas and mixtures up to grade 6.0
- Stainless steel 316L body for corrosive gases
- 4 ports flexible configuration
- Stable outlet pressure
- Simple outlet pressure limitation by handwheel
- Inlet filter
- Tested for use with oxygen



### Typical Applications

- Component Testing
- Calibration Systems
- Laboratory Pressure Control
- High Pressure Sampling Systems
- Service & Test Equipment

VSR-2EL



VSR-2ELP



Mounting panel  
Model No.: VSR-T-BPB

### Dimensions (mm)

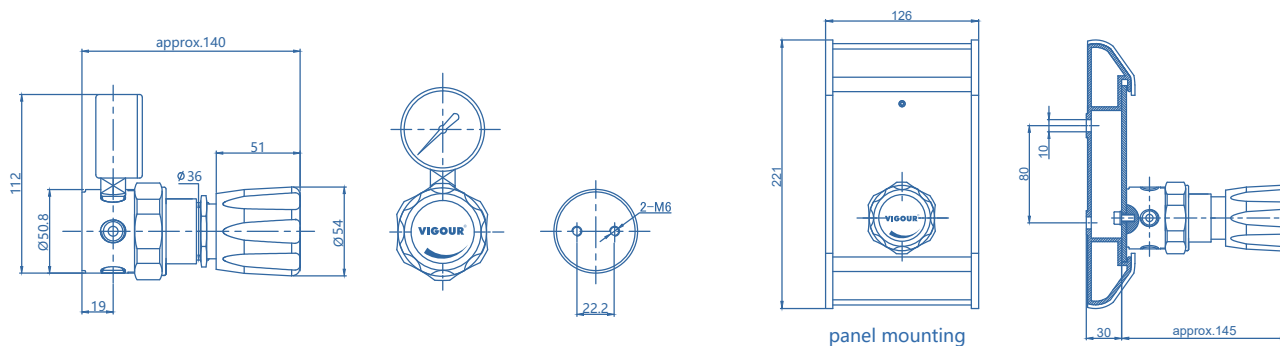

### Technical Data

Type:	single-stage
Inlet pressure P <sub>1</sub> :	max. 100bar
Outlet pressure P <sub>2</sub> :	vac/ 2/4/10/20/ 35/50 bar
Materials	
Body regulator	see ordering info
Valve seat:	PCTFE
Diaphragm:	Hastelloy® C276
O-ring: (option)	Viton® (FKM) Kalrez® (FFKM)
Filter:	SS 316L
Inlets and Outlets:	1/4" NPT(F)
Temperature range:	-30°C to +74°C
Leak rate (to atmosphere) (via seat)	1x10 <sup>-8</sup> mbar l/s He 1x10 <sup>-6</sup> mbar l/s He
Flow capacity: (P <sub>2</sub> =35/50 bar)	C <sub>v</sub> =0.08
(P <sub>2</sub> =2/4/10/20 bar)	C <sub>v</sub> =0.28
Weight:	1.25 kg

### Flow Chart

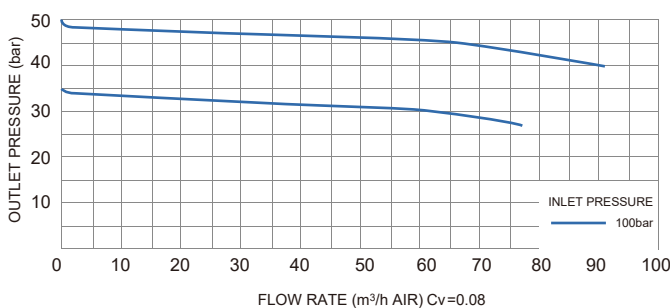
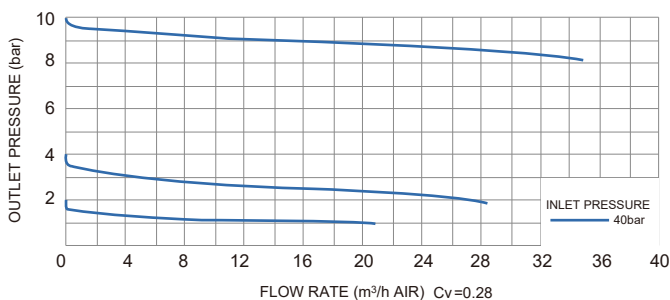

# Leitungs- & Paneldruckminderer/Panel & Line Regulators VSR-2EL & VSR-2ELP Series

## Ordering Information



### Inlets / Outlets

F4: 1/4"NPT(F)	02: 1/8" Tube fitting	8M: 8mm Tube fitting
M4: 1/4"NPT(M)	04: 1/4" Tube fitting	TW12M: 12mm Weld tube
F6: 3/8" NPT(F)	06: 3/8" Tube fitting	P: Gauge(Psig/bar)
M6: 3/8" NPT(M)	6M: 6mm Tube fitting	B: Plug

\* Other connection standard, consult factory.

### Port Selection

VSR - 2EL S - 100 - 20 - 1 - 2 - 3 - 4 - N<sub>2</sub>

#### Type

L: Line  
LP: Panel

#### Body Material

S: 316L  
C: Chrome Plated Brass

#### Inlet Pressure P<sub>1</sub>

40: 40 bar  
100: 100 bar

#### Outlet Pressure P<sub>2</sub>

2: to 2 bar  
4: to 4 bar  
10: to 10 bar  
20: to 20 bar  
35: to 35 bar  
50: to 50 bar  
V2: -1bar to 2 bar  
V4: -1bar to 4 bar  
V10: -1bar to 10 bar  
V20: -1bar to 20 bar

#### Type of Gas

Please specify type of gas

## Ordering Example

Example: VSR - 2EL C - 100 - 20 - F4 - P - F4 - B - O<sub>2</sub>

1 - 2 - 3 - 4





# Panel & Line Regulators / Leitungs- & Paneldruckminderer

## VSR-3L & VSR-3LP Series

### Product Features

- Line and Panel mounting pressure regulator
- Brass chrome plated body for inert, reactive, flammable and oxidizing gas and mixtures up to grade 6.0
- Stainless steel 316L body for corrosive gases
- 4 ports flexible configuration
- Stable outlet pressure
- Simple outlet pressure limitation by handwheel
- Inlet filter
- Tested for use with oxygen



### Typical Applications

- Component Testing
- Calibration Systems
- Laboratory Pressure Control
- High Pressure Sampling Systems
- Service & Test Equipment

VSR-3L



VSR-3LP



Mounting panel  
Model No.: VSR-T-BPB

### Dimensions (mm)

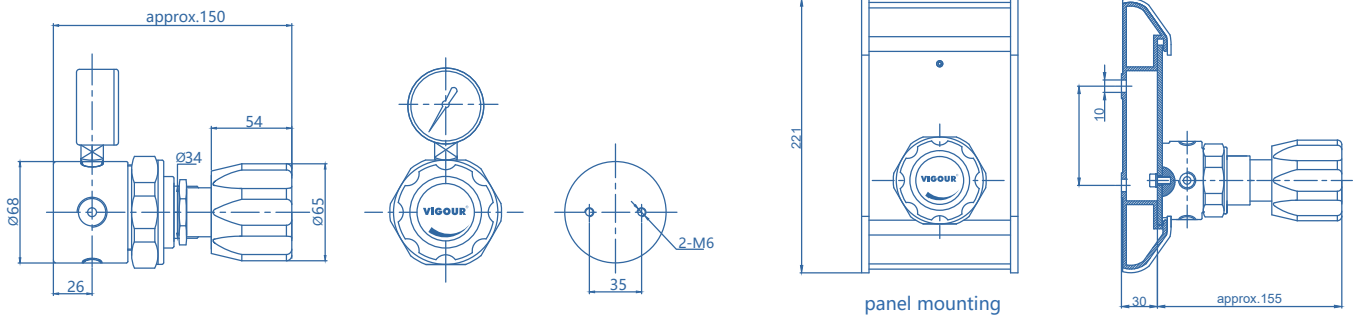

### Technical Data

Type:	single-stage
Inlet pressure P <sub>1</sub> :	max. 100 bar
Outlet pressure P <sub>2</sub> :	2/4/10/20/35/50 bar
Materials	
Body regulator	see ordering info
Valve seat:	PCTFE
Diaphragm:	Hastelloy® C276
O-ring: (option)	Viton® (FKM) Kalrez® (FFKM)
Filter:	SS 316L
Inlets and Outlets:	see ordering info
Temperature range:	-30°C to +74°C
Leak rate (to atmosphere) (via seat)	1x10 <sup>-8</sup> mbar l/s He 1x10 <sup>-6</sup> mbar l/s He
Flow capacity:	C <sub>v</sub> =1.7
Weight:	2.8 kg

### Flow Chart

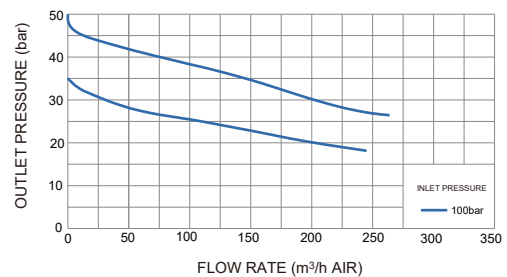
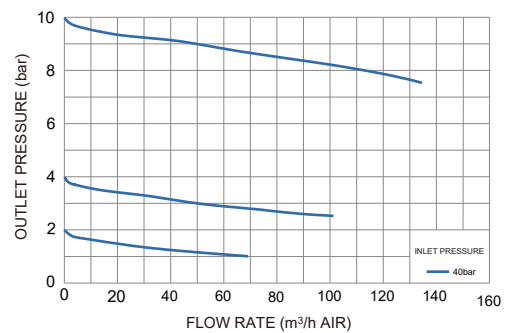

# Leitungs- & Paneldruckminderer / Panel & Line Regulators VSR-3L & VSR-3LP Series

## Ordering Information

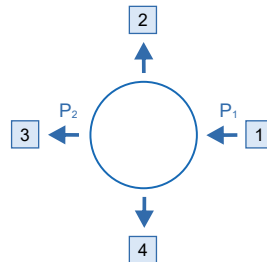

### Inlets / Outlets

F4: 1/4"NPT(F)	TW12M: 12mm Weld tube
F6: 3/8"NPT(F)	TW20M: 20mm Weld tube
F8: 1/2"NPT(F)	P: Gauge(Psig/bar)
F12: 3/4"NPT(F)	B: Plug

\* Other connection standard, consult factory.

### Port Selection

**VSR - 3L S - 100 - 20 - 1 - 2 - 3 - 4 - N<sub>2</sub>**

#### Type

- L: Line
- LP: Panel

#### Body Material

- S: 316L
- C: Chrome Plated Brass

#### Inlet Pressure P<sub>1</sub>

- 40: 40 bar
- 100: 100 bar

#### Type of Gas

Please specify type of gas

#### Outlet Pressure P<sub>2</sub>

- 2: to 2 bar
- 4: to 4 bar
- 10: to 10 bar
- 20: to 20 bar
- 35: to 35 bar
- 50: to 50 bar

## Ordering Example

Example: **VSR - 3L S - 100 - 4 - F8 - P - F8 - B - O<sub>2</sub>**

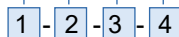

# Line Regulators / Leitungsdruckminderer

## VSR-4L Series

### Product Features

- Low pressure, high flow regulator
- Brass chrome plated body for inert, reactive, flammable and oxidizing gas and mixtures up to grade 6.0
- Stainless steel 316L body for pharmaceutical, food, and beverage application
- 4 ports flexible configuration
- Stable outlet pressure
- Tested for use with oxygen

### Typical Applications

- Component Testing
- Calibration Systems
- Laboratory Pressure Control
- High Pressure Sampling Systems
- Service & Test Equipment

### Dimensions (mm)

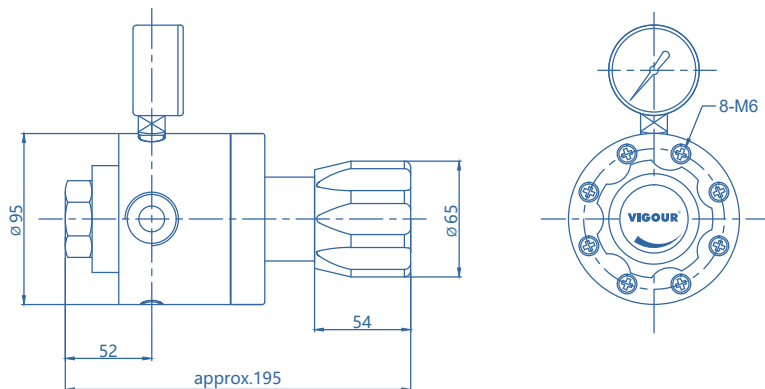

### Technical Data

Type:	single-stage
Inlet pressure P <sub>1</sub> :	max. 35 bar
Outlet pressure P <sub>2</sub> :	2/4/10/20 bar
Materials	
Body regulator	see ordering info
Valve seat:	EPDM(Buna-N option)
Diaphragm:	PTFE+Neoprene
Inlets and Outlets:	see ordering info
Temperature range:	-15°C to +74°C
Leak rate	Bubble-tight
Flow capacity:	C <sub>v</sub> =5.1
Weight:	4.10 kg

### Flow Chart

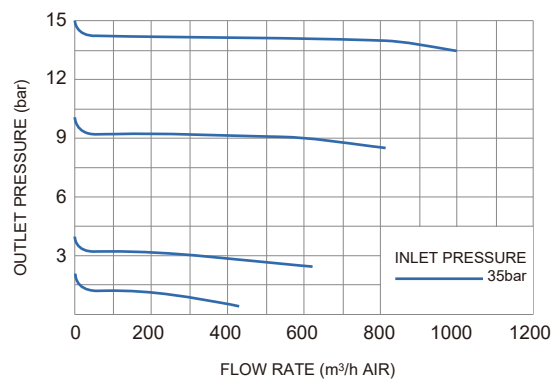

# Leitungsdruckminderer/Line Regulators VSR-4L Series

## Ordering Information



### Inlets / Outlets

F4: 1/4" NPT(F)	M12: 3/4" NPT(M)	12M: 3/4" Tube fitting
F8: 1/2" NPT(F)	F16: 1" NPT(F)	16M: 1" Tube fitting
M8: 1/2" NPT(M)	M16: 1" NPT(M)	P: Gauge(Psig/bar)
F12: 3/4" NPT(F)	TW20M: 20mm Weld tube	B: Plug

\* Other connection standard, consult factory.

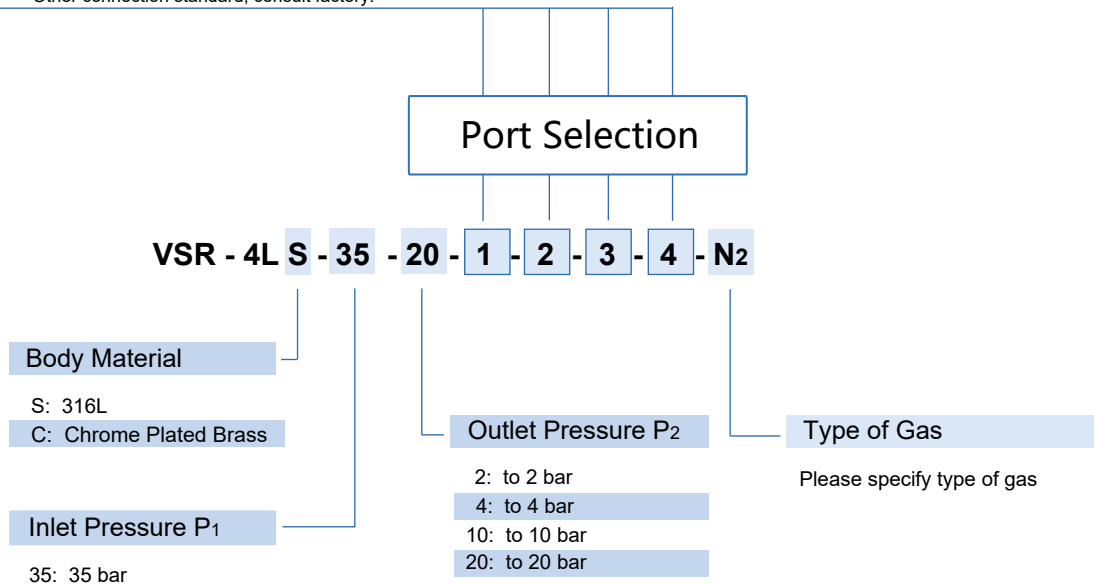

## Ordering Example

**Example: VSR - 4L S - 35 - 10 - F16 - P - F16 - B - O<sub>2</sub>**

1 - 2 - 3 - 4



# Panel & Line Regulators / Leitungs- & Paneldruckminderer

## VSR-6EL & VSR-6ELP Series

### Product Features

- Diaphragm design high pressure piston regulator
- Line and Panel mounting pressure regulator
- Brass chrome plated body and bonnet for inert, reactive, flammable and oxidizing gas and mixtures up to grade 6.0
- Stainless steel 316L body for corrosive gases
- 4 ports flexible configuration
- Simple outlet pressure limitation by handwheel
- Stable outlet pressure
- Inlet filter
- Tested for use with oxygen



### Typical Applications

- Component Testing
- Calibration Systems
- Laboratory Pressure Control
- High Pressure Sampling Systems
- Service & Test Equipment

VSR-6EL



VSR-6ELP



Mounting panel  
Model No.: VSR-T-BPB

### Dimensions (mm)

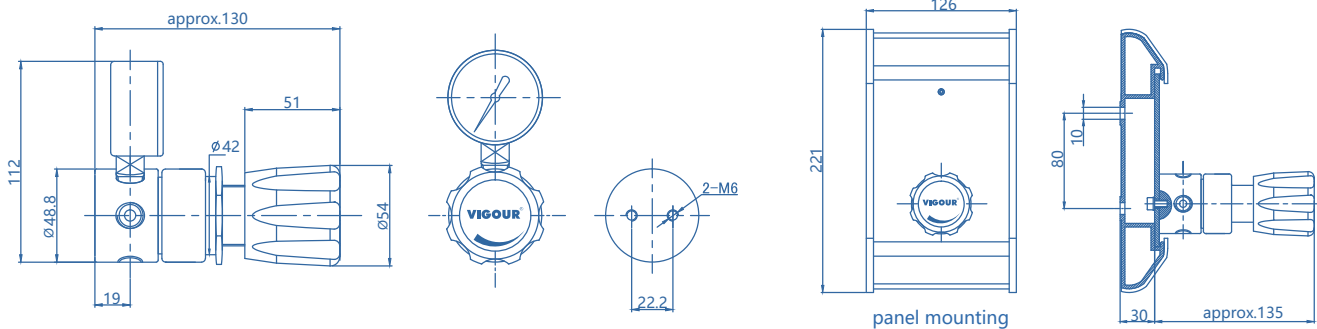

### Technical Data

Type:	single-stage
Inlet pressure P <sub>1</sub> :	max. 300 bar
Outlet pressure P <sub>2</sub> :	50/100/200 bar
Materials	
Body regulator:	see ordering info
Valve seat:	PCTFE
Piston:	SS316L
O-ring:	Viton® (FKM)
(option)	Kalrez® (FFKM)
Filter:	SS 316L
Inlets and Outlets:	1/4" NPT(F)
Temperature range:	-30°C to +74°C
Leak rate (to atmosphere)	1x10 <sup>-8</sup> mbar l/s He
(via seat)	1x10 <sup>-6</sup> mbar l/s He
Flow capacity:	Cv=0.15
Weight:	1.13 kg

### Flow Chart

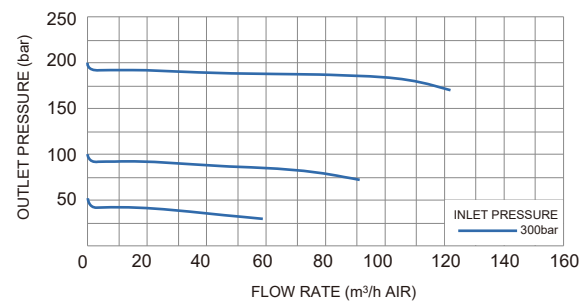

# Leitungs- & Paneldruckminderer / Panel & Line Regulators VSR-6EL & VSR-6ELP Series

## Ordering Information



### Inlets / Outlets

F4: 1/4"NPT(F)	02: 1/8" Tube fitting	8M: 8mm Tube fitting	P: Gauge(Psig/bar)
M4: 1/4"NPT(M)	04: 1/4" Tube fitting	TW6M: 6mm weld tube	B: Plug
F6: 3/8" NPT(F)	06: 3/8" Tube fitting	TW8M: 8mm weld tube	
M6: 3/8" NPT(M)	6M: 6mm Tube fitting		

\* Other connection standard, consult factory.

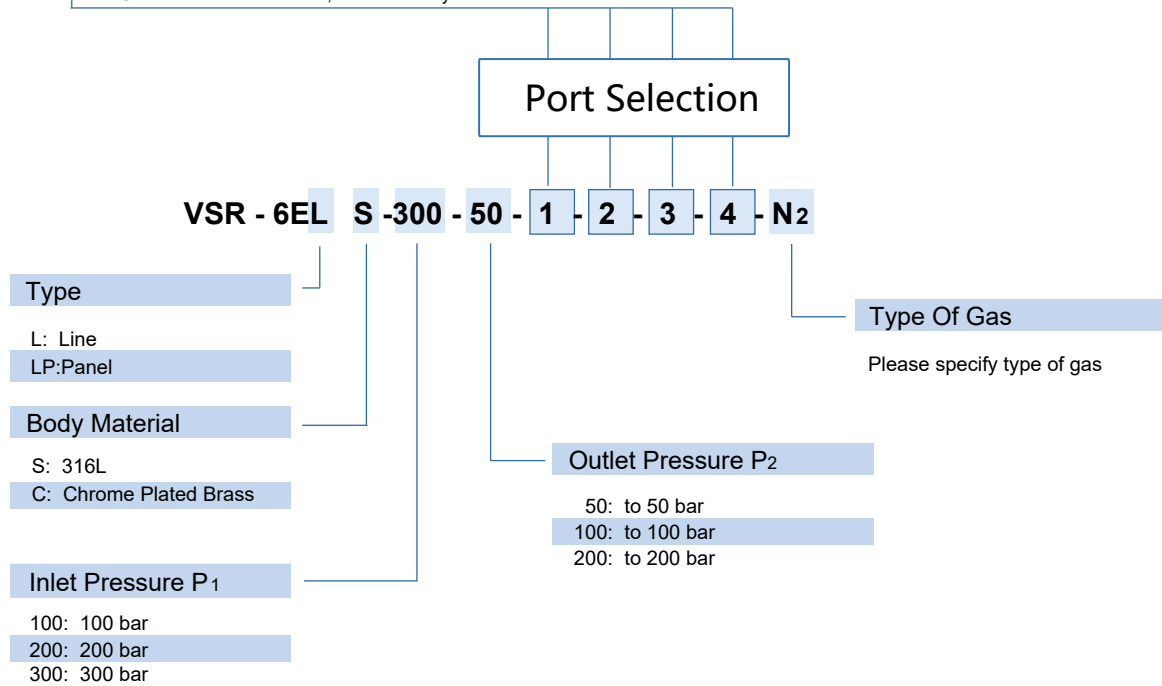

## Ordering Example

**Example: VSR - 6EL C - 200 - 50 - F4 - P - F4 - B - O<sub>2</sub>**

1 - 2 - 3 - 4



# Line Regulators / Leitungsdruckminderer

## VSR-12L & 12HL Series

### Product Features

- Low pressure, high flow regulator
- Brass chrome plated body for inert, reactive, flammable and oxidizing gas and mixtures up to grade 6.0
- Stainless steel 316L body for pharmaceutical, food, and beverage application
- 4 ports flexible configuration
- Stable outlet pressure
- Tested for use with oxygen
- Large seat and diaphragm areas provide high capacity with sensitive control of delivery pressure with low falloff

### Typical Applications

- Component Testing
- Calibration Systems
- Laboratory Pressure Control
- Service & Test Equipment



VSR-12L Series



VSR-12HL Series

### Dimensions (mm)

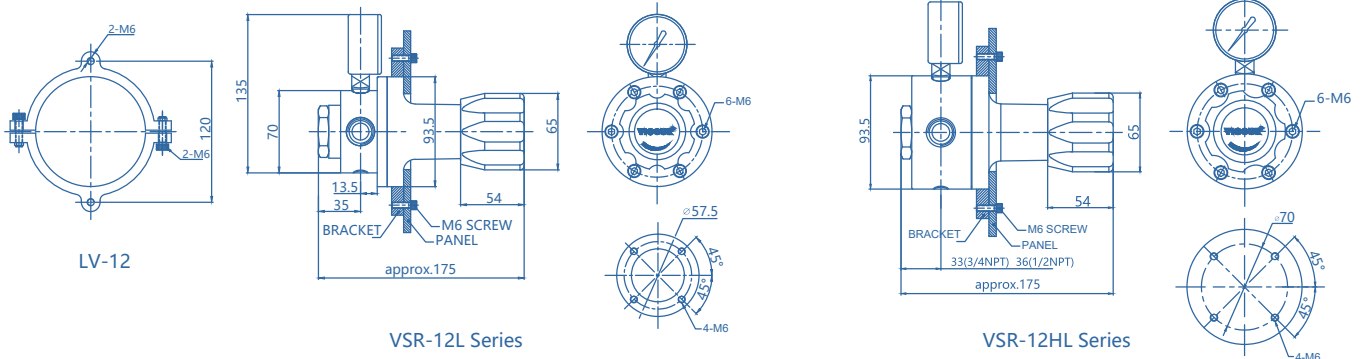

### Technical Data

Type:	single-stage
Inlet pressure P <sub>1</sub> :	Max 35 bar
Outlet pressure P <sub>2</sub> :	1/2/8/10/20 bar
Materials	
Body regulator	see ordering info
Seat:	EPDM(Viton® option)
Diaphragm:	PTFE+Buna-N
Inlets and Outlets:	see ordering info
Temperature range:	-15°C to +74°C
Leak rate	Bubble-tight
Weight:	approx. 2.5kg / 3.7kg

### Flow Chart

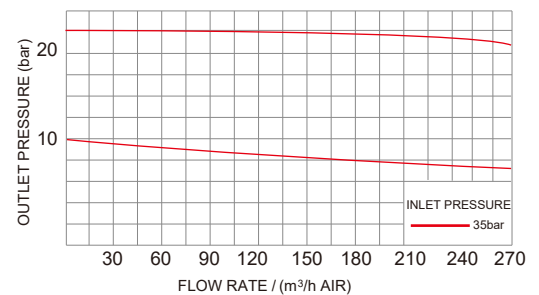
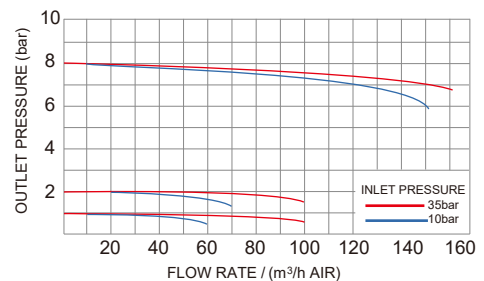

# Leitungsdruckminderer / Line Regulators VSR-12L & 12HL Series

## Ordering Information

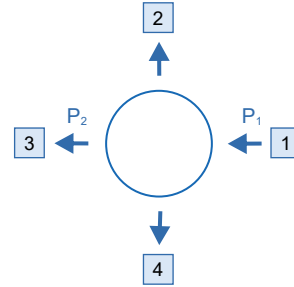

### Inlets / Outlets

F4: 1/4" NPT(F)  
F8: 1/2" NPT(F)  
F12: 3/4" NPT(F) (only for VSR-12HL series)  
12: 3/4" Tube fitting

16: 1" Tube fitting  
TW20M: 20mm Weld tube  
P: Gauge(Psig/bar)  
B: Plug

\* Other connection standard, consult factory.

### Port Selection

VSR - 12L S - 35 - 20 - 1 - 2 - 3 - 4 - E - N<sub>2</sub>

#### Series

L: L series  
HL: HL series

#### Body Material

S: 316L  
C: Chrome Plated Brass

#### Inlet Pressure P<sub>1</sub>

35: 35 bar

#### Outlet Pressure P<sub>2</sub>

1: to 1 bar  
2: to 2 bar  
8: to 8 bar  
10: to 10 bar  
20: to 20 bar

#### Type of Gas

Please specify type of gas

#### Seat Diaphragm

V: Viton  
E: EPDM(standard)

## Ordering Example

Example: VSR - 12L S - 35 - 10 - F8 - P - F8 - B - O<sub>2</sub>

1 - 2 - 3 - 4





# Line Regulators / Leitungsdruckminderer

## VSR-3PH Series

### Product Features

- Line pressure regulator
- Stainless steel 316L body
- 2 or 3 ports configuration
- Stable outlet pressure

### Typical Applications

- Pharmaceutical Industry
- Food and Beverage Industry



### Schematic Drawing

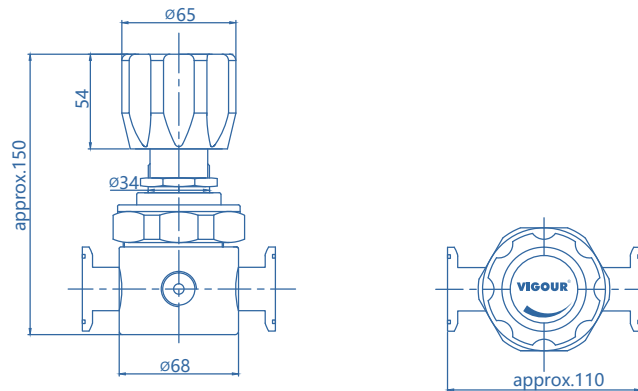

### Technical Data

Type:	single-stage
Inlet pressure P <sub>1</sub> :	max. 40 bar
Outlet pressure P <sub>2</sub> :	2/4/10 bar
Materials	
Body regulator	see ordering info
Valve seat:	PCTFE
Diaphragm:	Hastelloy® C276
O-ring: (option)	Viton® (FKM) Kalrez® (FFKM)
Filter:	SS 316L
Inlets and Outlets:	see ordering info
Temperature range:	-30°C to +74°C
Leak rate (to atmosphere) (via seat)	1x10 <sup>-8</sup> mbar l/s He 1x10 <sup>-6</sup> mbar l/s He
Flow capacity:	Cv=1.7
Weight:	2.8 kg

### Flow Chart

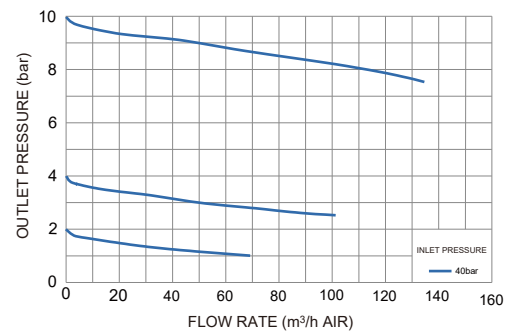

# Leitungsdruckminderer / Line Regulators VSR-3PH Series

## Ordering Information

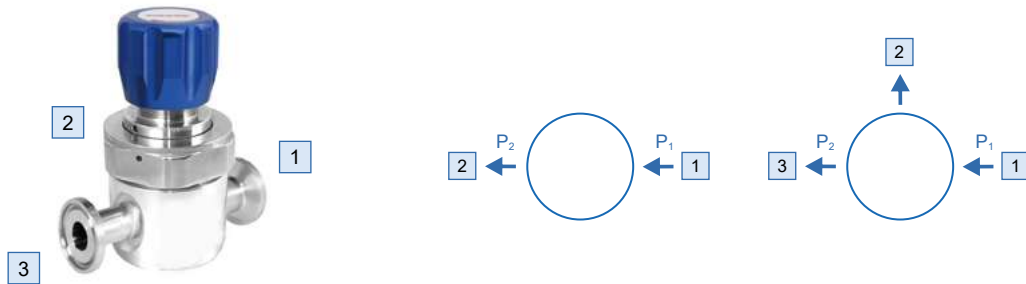

### Inlets / Outlets

S16: 1"Sanitary	TW8: 1/2"Weld tube	TW20M: 20mm Weld tube
S32: 2"Sanitary	TW12: 3/4"Weld tube	FV4: 1/4" VFS female
S40: 2-1/2"Sanitary	TW12M: 12mm Weld tube	P: Gauge(Psig/bar)

\* Other connection standard, consult factory.

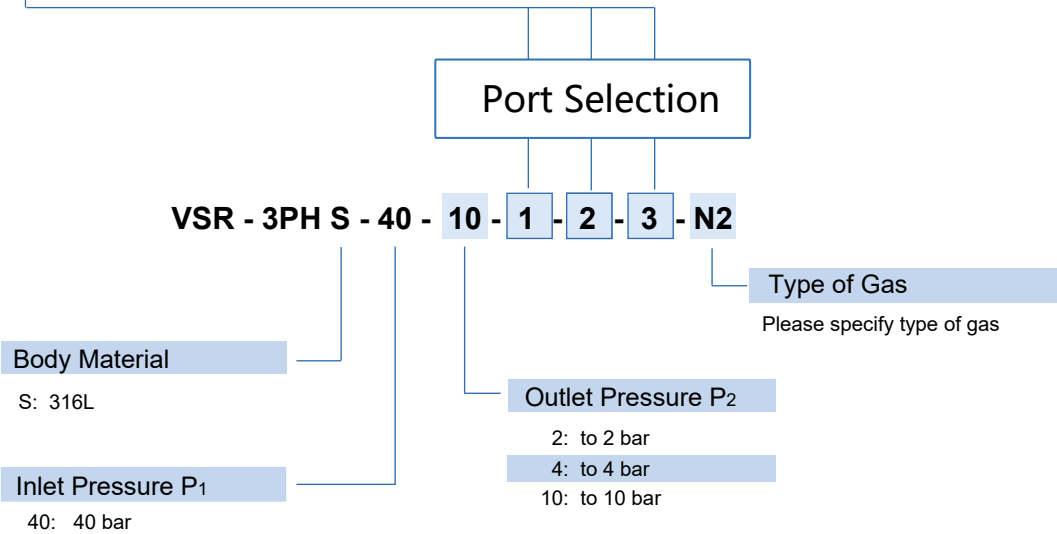

## Ordering Example

**Example:** VSR - 3PH S - 40 - 4 - S16 - FV4 - S16 - N<sub>2</sub>

1 - 2 - 3



# Line Regulators / Leitungsdruckminderer

## VSR-4PH Series

### Product Features

- Line pressure regulator
- Stainless steel 316L body
- 2 or 3 ports configuration
- Stable outlet pressure

### Typical Applications

- Pharmaceutical Industry
- Food and Beverage Industry



### Schematic Drawing

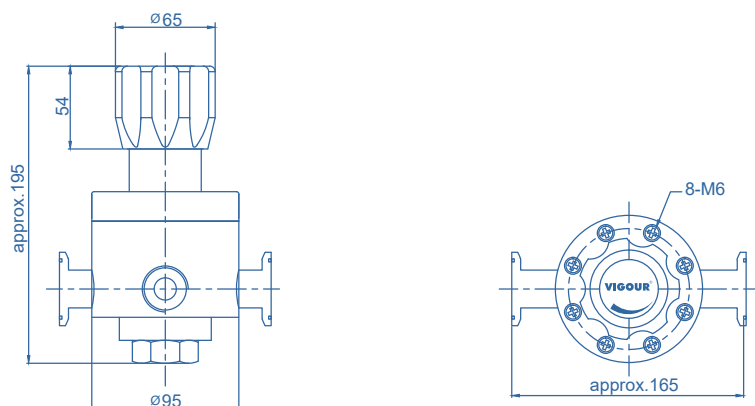

### Technical Data

Type:	single-stage
Inlet pressure P <sub>1</sub> :	max. 35 bar
Outlet pressure P <sub>2</sub> :	2/4/10/20 bar
Materials	
Body regulator	see ordering info
Valve seat:	Buna-N
Diaphragm:	Neoprene+PTFE
Inlets and Outlets:	see ordering info
Temperature range:	-15°C to +74°C
Leak rate	Bubble-tight
Flow capacity:	C <sub>v</sub> =5.1
Weight:	4.20 kg

### Flow Chart

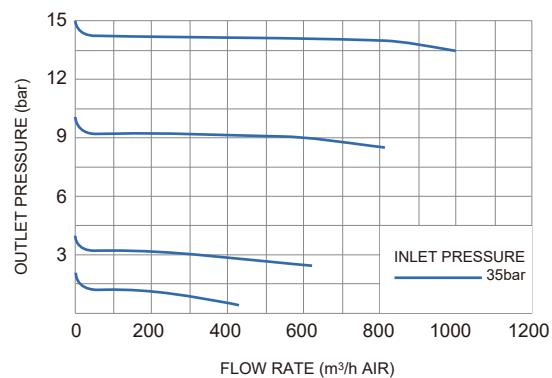

# Leitungsdruckminderer / Line Regulators VSR-4PH Series

## Ordering Information

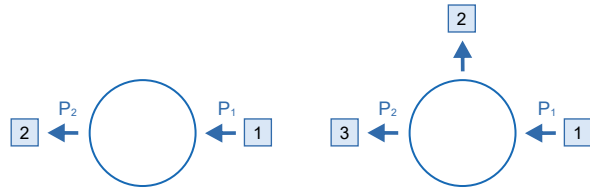

### Inlets / Outlets

S16: 1"Sanitary

S32: 2"Sanitary

S40: 2-1/2"Sanitary

TW8: 1/2"Weld tube

TW12: 3/4"Weld tube

TW16: 1"Weld tube

TW24: 1-1/2"Weld tube

TW12M: 12mm Weld tube

TW20M: 20mm Weld tube

TW25M: 25mm Weld tube

TW30M: 30mm Weld tube

FV4: 1/4" VFS female

P: Gauge(Psig/bar)

\* Other connection standard, consult factory.

### Port Selection

VSR - 4PH S - 35 - 10 - 1 - 2 - 3 - N<sub>2</sub>

### Body Material

S: 316L

### Inlet Pressure P<sub>1</sub>

35: 35 bar

### Outlet Pressure P<sub>2</sub>

2: to 2 bar

4: to 4 bar

10: to 10 bar

20: to 20 bar

### Type of Gas

Please specify type of gas

## Ordering Example

Example: VSR - 4PH S - 35 - 10 - S16 - FV4 - S16 - N<sub>2</sub>

1 - 2 - 3



# Line Regulators / Leitungsdruckminderer

## VSR-3F Series

### Product Features

- Line pressure regulator
- Stainless steel 316L body
- 4 ports configuration
- Stable outlet pressure

### Typical Applications

- Pharmaceutical Industry
- Food and Beverage Industry



### Schematic Drawing

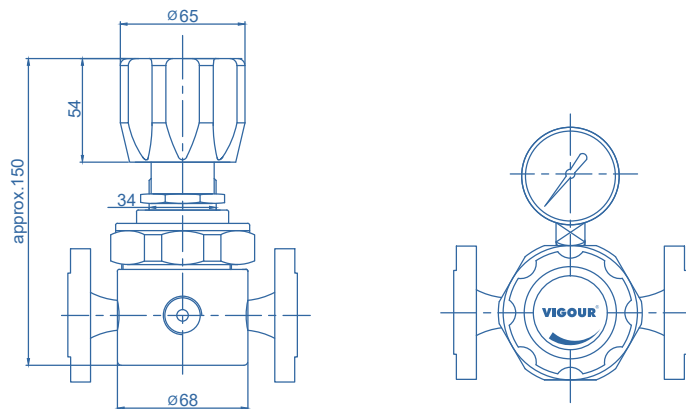

### Technical Data

Type:	single-stage
Inlet pressure P <sub>1</sub> :	max. 40 bar
Outlet pressure P <sub>2</sub> :	2/4/10/20 V2/V10 bar
Materials	
Body regulator	see ordering info
Valve seat:	PCTFE
Diaphragm:	Hastelloy® C276
O-ring: (option)	Viton® (FKM) Kalrez® (FFKM)
Filter:	SS 316L
Inlets and Outlets:	see ordering info
Temperature range:	-30°C to +74°C
Leak rate (to atmosphere) (via seat)	1x10 <sup>-8</sup> mbar l/s He 1x10 <sup>-6</sup> mbar l/s He
Flow capacity:	C <sub>v</sub> =1.7
Weight:	3.20 kg

### Flow Chart

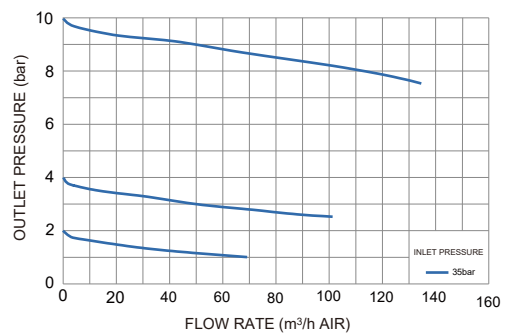

# Leitungsdruckminderer / Line Regulators VSR-3F Series

## Ordering Information

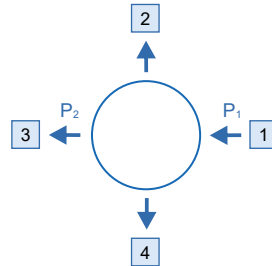

### Inlets / Outlets

D10: DN10 Flange  
D15: DN15 Flange  
D20: DN20 Flange

D25: DN25 Flange  
D30: DN30 Flange  
F4: 1/4" NPT(F)

P: Gauge(Psig/bar)  
B: plug

\* Other connection standard, consult factory.

### Port Selection

VSR - 3FS - 40 - 10 - 1 - 2 - 3 - 4 - N2

### Body Material

S: 316L

### Inlet Pressure P1

40: 40 bar

### Outlet Pressure P2

2: to 2 bar

4: to 4 bar

10: to 10 bar

20: to 20 bar

V2: 30 in Hg VAC ~ 2 bar

V10: 30 in Hg VAC ~ 10 bar

### Type of Gas

Please specify type of gas

## Ordering Example

Example: VSR - 3FS - 40 - 10 - D10 - F4 - D10 - B - N2

1 - 2 - 3 - 4



# Line Regulators / Leitungsdruckminderer

## VSR-4F Series

### Product Features

- Line pressure regulator
- Stainless steel 316L body
- 4 ports configuration
- Stable outlet pressure

### Typical Applications

- Pharmaceutical Industry
- Food and Beverage Industry



### Schematic Drawing

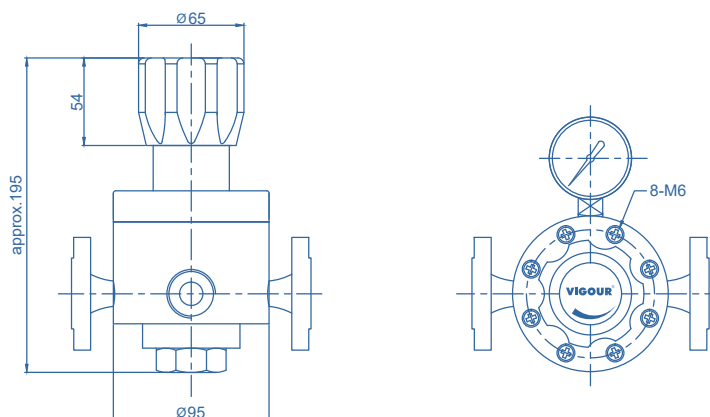

### Technical Data

Type:	single-stage
Inlet pressure P <sub>1</sub> :	max. 35 bar
Outlet pressure P <sub>2</sub> :	2/4/10/20 bar
Materials	
Body regulator	see ordering info
Valve seat:	Buna-N
Diaphragm:	Neoprene+PTFE
Inlets and Outlets:	see ordering info
Temperature range:	-15°C to +74°C
Leak rate	Bubble-tight
Flow capacity:	C <sub>v</sub> =5.1
Weight:	5.10 kg

### Flow Chart

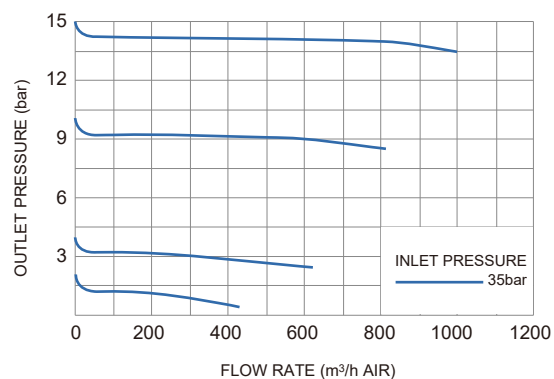

# Leitungsdruckminderer / Line Regulators VSR-4F Series

## Ordering Information

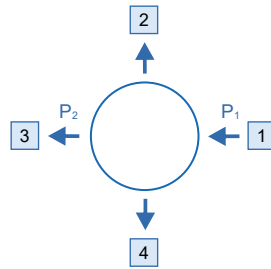

### Inlets / Outlets

D20: DN20 Flange    F4: 1/4" NPT(F)    B: plug  
 D25: DN25 Flange    P: Gauge(Psig/bar)

\* Other connection standard, consult factory.

### Port Selection

VSR - 4FS - 35 - 10 - 1 - 2 - 3 - 4 - N2

#### Body Material

S: 316L

#### Inlet Pressure P<sub>1</sub>

35: 35 bar

#### Outlet Pressure P<sub>2</sub>

2: to 2 bar  
 4: to 4 bar  
 10: to 10 bar  
 20: to 20 bar

#### Type of Gas

Please specify type of gas

## Ordering Example

Example: VSR - 4FS - 35 - 10 - D20 - F4 - D20 - B - N2

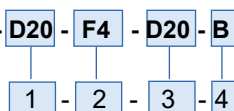



# Back Pressure Regulators / Leitungs- & Paneldruckminderer

## VSR-51 Series

### Product Features

- Reduces contamination and provides accurate regulation of corrosive or non-corrosive gases
- Close pressure differential between crack and reseal
- Compact and economical
- Panel mounting is available
- Tested for use with oxygen



### Typical Applications

- Analytical systems
- Gas sampling
- Pilot plants
- OEM packages
- R & D laboratories

### Dimensions (mm)

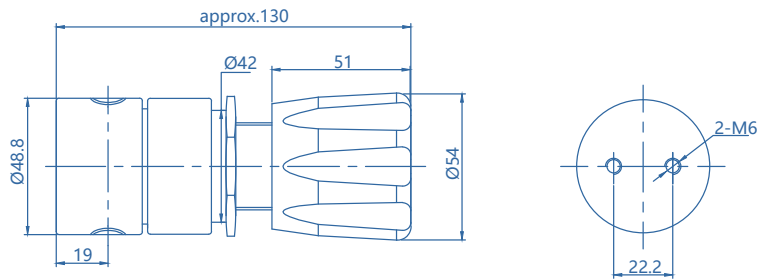

### Technical Data

Inlet pressure P <sub>1</sub> :	max. 17 bar
Controlled pressure:	see ordering info
<b>Materials</b>	
Body regulator, relief valve:	see ordering info
Valve seat:	PCTFE
Diaphragm:	Hastelloy®
O-ring:	Viton® (FKM)
(option)	Kalrez® (FFKM)
Filter:	SS 316L
Inlets and Outlets:	1/4" NPT(F)
Temperature range:	-30°C to +74°C
Leak rate (to atmosphere) (via seat)	2x10 <sup>-8</sup> mbar l/s He Bubble tight
Flow capacity:	C <sub>v</sub> =0.08
Weight:	1 kg

### Flow Chart

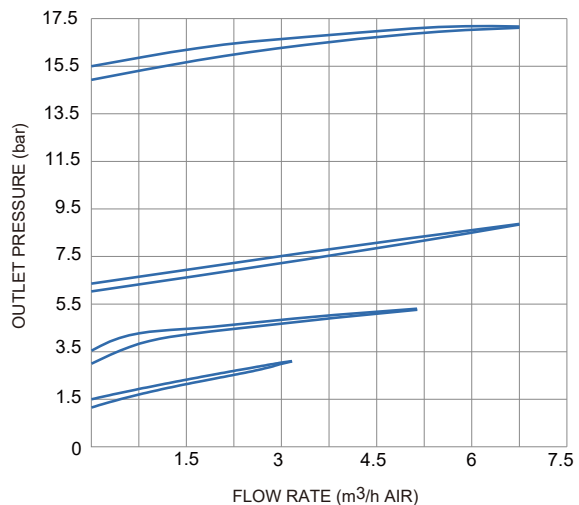

# Leitungs- & Paneldruckminderer / Back Pressure Regulators VSR-51 Series

## Ordering Information

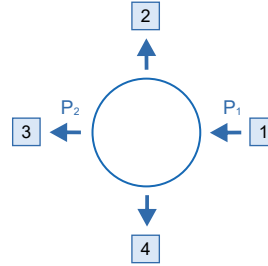

**Inlets / Outlets**  
 F4: 1/4"NPT(F)    P: Gauge(Psig/bar)    B: plug  
 \* Other connection standard, consult factory.

### Port Selection

**VBR - 51P S - 17 - 1 - 2 - 3 - 4 - N2**

**Mounting**  
 L: Line mounting  
 P: Panel mounting

**Body Material**  
 S: 316L  
 C: Chrome Plated Brass

**Type of Gas**  
 Please specify type of gas

**Controlled Pressure Range**  
 2: 0-2 bar  
 4: 0-4 bar  
 7: 0-7 bar  
 17: 0-17 bar

## Ordering Example

**Example: VSR - 51LS - 17 - F4 - P - F4 - F4 - O<sub>2</sub>**  
 1 - 2 - 3 - 4



\* For mixed gases, please specify cylinder connection standard and thread when ordering.

# Back Pressure Regulators / Leitungs- & Paneldruckminderer

## VSR-52 Series

### Product Features

- Economical, compact design
- Piston sensed design is safe and reliable
- Available in a Stainless Steel or Brass design
- Optional gauge ports and panel mounting
- Low handknob torque for easy operation
- Bubble-tight shutoff at all reseating pressures
- Tested for use with oxygen



### Typical Applications

- Industrial equipment for hydraulic or pneumatic service

### Dimensions (mm)

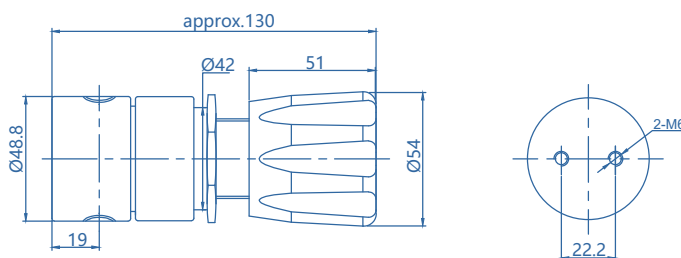

### Technical Data

Inlet pressure P <sub>1</sub> :	max. 50 bar
Controlled pressure:	see ordering info
Materials	
Body regulator, relief valve:	see ordering info
Valve seat:	PCTFE
Piston:	SS316L
O-ring:	Viton® (FKM)
(option)	Kalrez® (FFKM)
Filter:	SS 316L
Inlets and Outlets:	1/4" NPT(F)
Temperature range:	-30°C to +74°C
Leak rate	Bubble-tight
Flow capacity:	C <sub>v</sub> =0.1
Weight:	1 kg

### Flow Chart

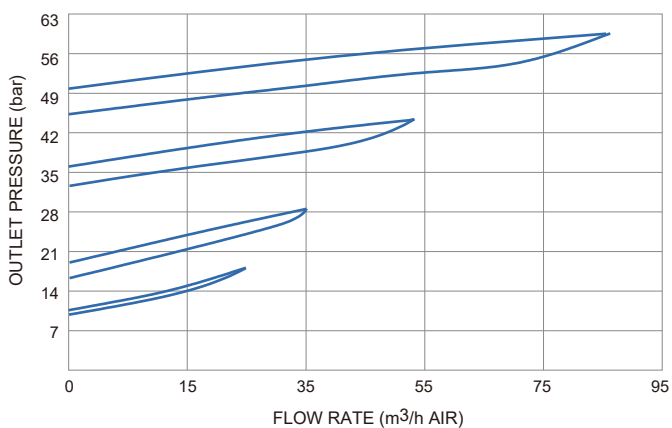

# Leitungs- & Paneldruckminderer / Back Pressure Regulators VSR-52 Series

## Ordering Information

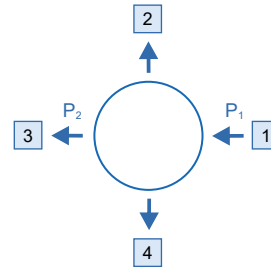

### Inlets / Outlets

F4: 1/4"NPT(F)    P: Gauge(Psig/bar)    B: plug

\* Other connection standard, consult factory.

### Port Selection

VSR - 52L S - 10 - 1 - 2 - 3 - 4 - N<sub>2</sub>

#### Mounting

L: Line mounting  
P: Panel mounting

#### Body Material

S: 316L  
C: Chrome Plated Brass

#### Type of Gas

Please specify type of gas

#### Controlled Pressure Range

10: 3-10 bar  
20: 3-20 bar  
50: 7-50 bar

## Ordering Example

Example: VSR - 52LS - 10 - F4 - P - F4 - F4 - N<sub>2</sub>

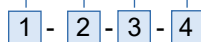

\* For mixed gases, please specify cylinder connection standard and thread when ordering.

# Back Pressure Regulators / Leitungs- & Paneldruckminderer

## VSR-53 Series

### Product Features

- Function similar to relief valve, ease of adjustment.
- Panel and line mounting
- Accuracy:  $\pm 1\%$  of central pressure range
- Bubble-tight shut-off at all reseal pressures
- Tested for use with oxygen



### Typical Applications

- Pump discharge pressure control
- Reactor pressure control
- Over-pressurization relief

### Dimensions (mm)

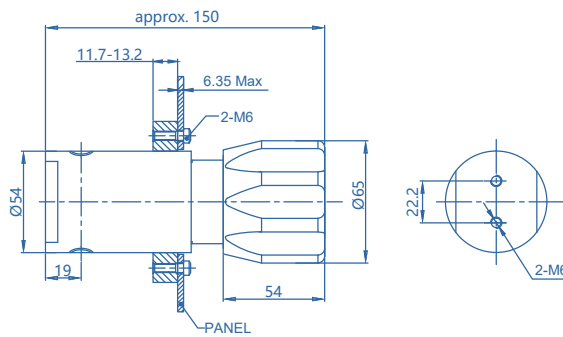

INLET AND OUTLET PORT	D
1/4 EXCEPT NPTF	58.4
1/4 AND 3/8 NPTF	63
3/8 MEDIUM AND HIGH PRESSURE	78.2
1/2 NPTF	84.6

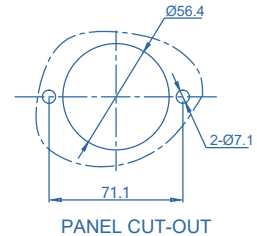
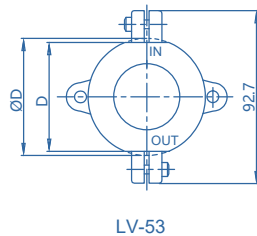

### Technical Data

Type:	single-stage
Inlet pressure P <sub>1</sub> :	max. 300 bar
Controlled pressure:	see ordering info
<b>Materials</b>	
Body regulator	see ordering info
Valve seat:	PCTFE
O-ring:	Viton® (FKM)
(option)	Kalrez® (FFKM)
Filter:	SS 316L
Piston:	SS 316L
Inlets and Outlets:	see ordering info
Temperature range:	-30°C to +74°C
Leak rate	Bubble-tight
Flow capacity:	C <sub>v</sub> =0.14 (<100bar)
	C <sub>v</sub> =0.1 (100~300bar)
Weight:	approx. 2 kg

### Flow Chart

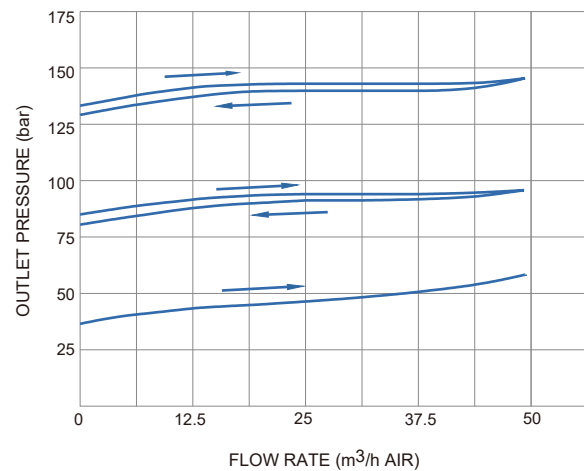

# Leitungs- & Paneldruckminderer / Back Pressure Regulators VSR-53 Series

## Ordering Information

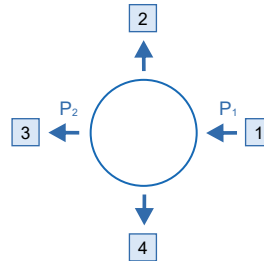

### Inlets / Outlets

F4: 1/4"NPT(F)	P: Gauge(Psig/bar)
F6: 3/8"NPT(F)	B: Plug
F8: 1/2" NPT(F)	

\* Gauge port is 1/4NPT(F)

### Port Selection

**VSR - 53L S - 50 - 1 - 2 - 3 - 4 - N<sub>2</sub>**

#### Type

L: Line  
P: Panel

#### Body Material

S: 316L

#### Type of Gas

Please specify type of gas

#### Controlled pressure range

35: 0.35-35 bar  
50: 0.35-50 bar  
100: 0.7-100 bar  
200: 1.72-200 bar  
300: 3.45-300 bar

## Ordering Example

**Example: VSR - 53LS - 50 - F4 - F4 - F4 - F4 - N<sub>2</sub>**

1 - 2 - 3 - 4



# Calibration Gas Regulators / Regler fuer Kalibriergase

## VSR-15 Series

### Product Features

- Cylinder pressure regulator
- Brass chrome plated body or stainless steel body
- Piston type

### Typical Applications

- Calibration system.

### Technical Data

Type:	single-stage
Inlet pressure :	max. 200 bar
Outlet pressure :	4 bar(standard) 2 bar(option)
Outlet flow settings :	see ordering info
Materials :	
Body regulator :	see ordering info
Temperature range:	-20°C to +50°C
Leak rate	1.10 <sup>-4</sup> mbar.l/s
Weight:	0.35 kg

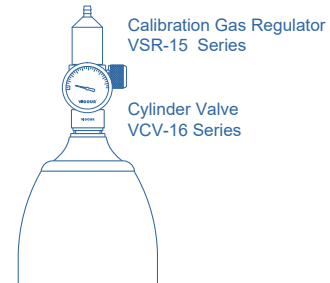

### Dimensions (mm)

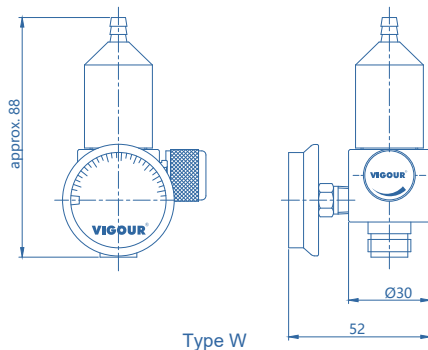

### Pressure Drop Curve

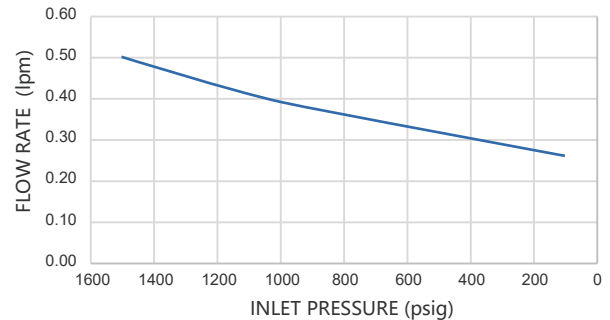

### Ordering Information

**VSR - 15C - 200 - 4 - 0.2 - C10 - 3/16 - W** — Flow Setting Type

W: Hand wheel

#### Body Material

- S: 316L
- C: Chrome Plated Brass

#### Inlet Pressure P<sub>1</sub>

- 20: 20 bar
- 200: 200 bar

#### Outlet Pressure P<sub>2</sub>

- 2: 2 bar (standard)
- 4: 4 bar (option)

#### Outlet connection

3/16: 3/16" Hose barb

#### Inlet connection

C10: 5/8-18 UNF(C-10)  
CGA600: CGA600

#### Norminal Flow

- |              |              |
|--------------|--------------|
| 0.2: 0.2 LPM | 1.5: 1.5 LPM |
| 0.3: 0.3 LPM | 2.5: 2.5 LPM |
| 0.5: 0.5 LPM | 5: 5 LPM     |
| 1: 1 LPM     | 6: 6 LPM     |

# Regler fuer Kalibriergase / Calibration Gas Regulators VSR-19 Series

## Product Features

- Cylinder pressure regulator
- Aluminum body
- Piston type
- On/Off valve

## Typical Applications

- Disposable cylinders of non-corrosive gases
- Calibration system

## Technical Data

Type:	single-stage
Maximum inlet pressure	200 bar
Outlet flow settings (orifice)	see ordering info
Materials :	
Body regulator :	aluminum
Inlet fitting	C10, CGA600
Outlet fitting	3/16" hose barb
Temperature operating range	-20°C to +50°C
Weight:	0.30 kg

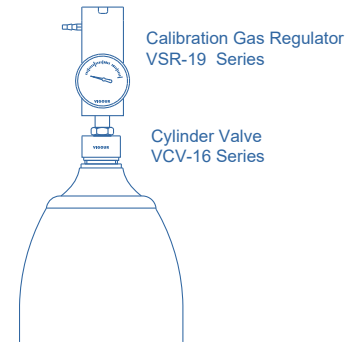

## Dimensions (mm)

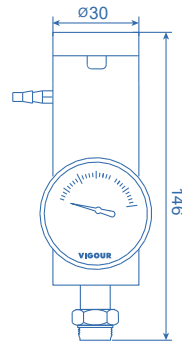

## Ordering Information

**VSR - 19A - 15 - C10 - 3/16**

Body Material

A: Aluminum

Outlet flow settings

2: 0.25-2 LPM

6: 0.5-6 LPM

8: 1-8 LPM

15: 2-15 LPM

Outlet connection

3/16: 3/16" Hose barb

Inlet connection

C10: C10

CGA600: CGA600



# High pressure self-venting Regulator / Druckminderer selbstentlüftend VSR-7 Series

## Product Features

- High pressure , high flow regulator
- Brass chrome plated body and bonnet for inert,reactive,flammable and oxidizing gas and mixtures up to grade 6.0
- Stainless steel 316L body for pharmaceutical, food, and beverage application
- Simple outlet pressure limitation by handwheel
- Self-venting standard
- Stable outlet pressure
- Tested for use with oxygen

## Typical Applications

- Component Testing
- Calibration Systems
- Laboratory Pressure Control
- High Pressure Sampling Systems
- Service & Test Equipment

## Dimensions (mm)

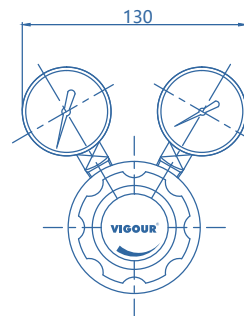
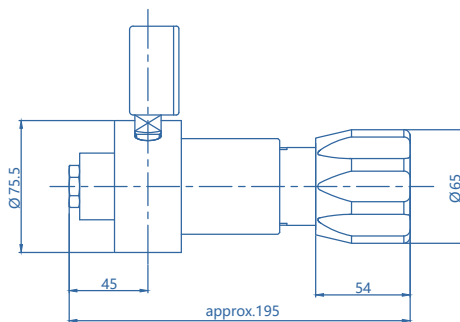

## Technical Data

Type:	single-stage
Inlet pressure P <sub>1</sub> :	max. 300 bar
Outlet pressure P <sub>2</sub> :	20/35/50/100 bar
Materials	
Body regulator:	see ordering info
Valve seat:	PCTFE
Filter:	SS 316L
O-ring:	Viton® (FKM)
Back-up ring:	PTFE
Gaskets:	PCTFE
Inlets and Outlets:	1/2" NPT(F) or 3/4" NPT(F)
Temperature range:	-30°C to +74°C
Leak rate (to atmosphere) (via seat)	Bubble-tight Bubble-tight
Flow capacity:	C <sub>v</sub> =0.8
Weight:	2.9 kg

## Flow Chart

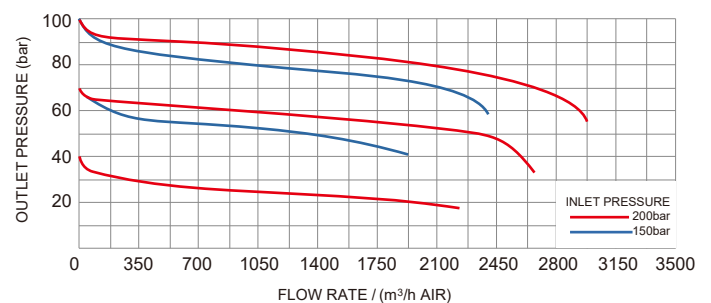

# Druckminderer selbstentlüftend / High Pressure Self-venting Regulator VSR-7 Series

## Ordering Information

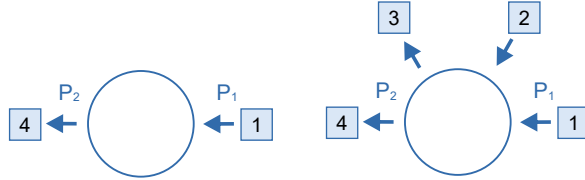

### Inlets / Outlets

F8: 1/2NPT(F)

F12: 3/4NPT(F)

TW12M: 12mm weld tube

TW20M: 20mm weld tube

P: Gauge(Psig/bar)

B: Plug

\* Other connection standard, consult factory.

### Port Selection

VSR - 7S - 200 - 20 - 1 - 2 - 3 - 4 - N2 - X

### Body Material

S: 316L

C: Chrome Plated Brass

### Option

X: Non self-venting

### Type Of Gas

Please specify type of gas

### Inlet Pressure P<sub>1</sub>

40: 40 bar

100: 100 bar

200: 200 bar

300: 300 bar

### Outlet Pressure P<sub>2</sub>

20: to 20 bar

35: to 35 bar

50: to 50 bar

100: to 100 bar

## Ordering Example

Example: VSR - 7S - 300 - 50 - F8 - P - P - F8 - N2

1 - 2 - 3 - 4



# High Pressure Self-venting Regulator / Druckminderer selbstentlüftend VSR-8 Series

## Product Features

- Piston type high pressure regulator
- Self-Venting standard
- Brass chrome plated body and bonnet for inert, reactive, flammable and oxidizing gas and mixtures up to grade 6.0
- Stainless steel 316L body and bonnet for corrosive gases
- 4 ports flexible configuration
- Stable outlet pressure
- Simple outlet pressure limitation by handwheel
- Inlet filter
- Tested for use with oxygen

## Typical Applications

- Component Testing
- Calibration Systems
- Laboratory Pressure Control
- High Pressure Sampling Systems
- Service & Test Equipment

## Dimensions (mm)

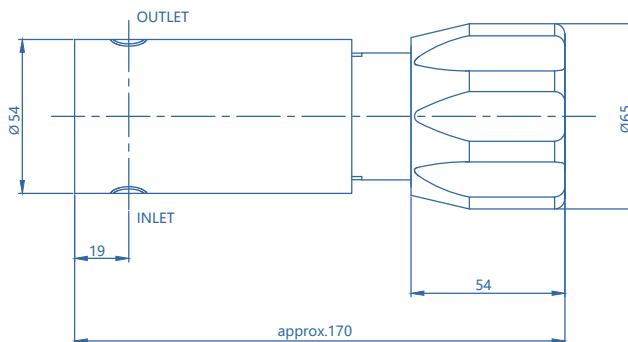

## Technical Data

Type:	single-stage
Inlet pressure P <sub>1</sub> :	Brass: max. 400 bar SS 316L: max. 400/700 bar
Outlet pressure P <sub>2</sub> :	35/50/100/200/400 bar
Materials	
Body regulator, relief valve:	see ordering info
Main Valve seat:	Vespel®
Vent Valve seat:	PCTFE
Piston:	SS 316L
O-ring:	Viton® (FKM)
(option)	Kalrez® (FFKM)
Filter:	SS 316L
Inlets and Outlets:	1/4" NPT(F)
Temperature range:	-30°C to +74°C
Leak rate	Bubble-tight
Flow capacity:	C <sub>v</sub> =0.06
Weight:	2.20 kg

## Flow Chart

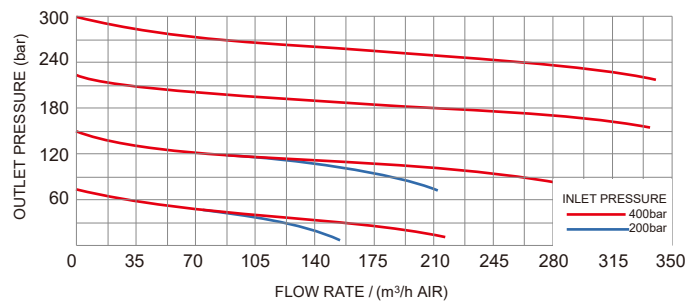

# Druckminderer selbstentlüftend / High Pressure Self-venting Regulator VSR-8 Series

## Ordering Information

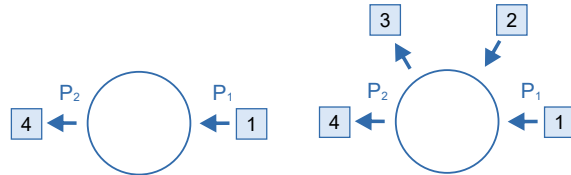

### Inlets / Outlets

F4: 1/4"NPT(F)	6M: 6mm Tube fitting	B: Plug
M4: 1/4"NPT(M)	8M: 8mm Tube fitting	
02: 1/8" Tube fitting	TW6M: 6mm Weld tube	
04: 1/4" Tube fitting	TW8M: 8mm Weld tube	
06: 3/8" Tube fitting	P: Gauge(Psig/bar)	

\* Other connection standard, consult factory.

### Port Selection

VSR - 8S - 400 - 200 - 1 - 2 - 3 - 4 - N2 - X

#### Body Material

S: 316L  
C: Chrome Plated Brass

#### Inlet Pressure P<sub>1</sub>

400: 400 bar (Brass / 316L)  
700: 700 bar (316L)

#### Outlet Pressure P<sub>2</sub>

35: to 35 bar  
50: to 50 bar  
100: to 100 bar  
200: to 200 bar  
300: to 300 bar  
400: to 400 bar

#### Option

X: Non self-venting

#### Type of Gas

Please specify type of gas

## Ordering Example

Example: VSR - 8C - 400 - 200 - F4 - F4 - F4 - F4 - N2 - X

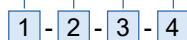

\* For mixed gases, please specify cylinder connection standard and thread when ordering.

# Manifold Regulators / Vielfältige Regulatoren

## VSR-36 Series

### Product Features

- Pressure regulator, piston type
- Brass body for inert, reactive, flammable and oxidizing gas and mixtures up to grade 6.0
- Stainless steel 316L body for corrosive gases
- 5 ports flexible configuration
- Stable outlet pressure
- Simple outlet pressure limitation by handwheel
- Inlet filter
- Tested for use with oxygen

### Typical Applications

- Component Testing
- Manifold Systems
- Laboratory Pressure Control
- High Pressure Sampling Systems
- Service & Test Equipment

### Dimensions (mm)

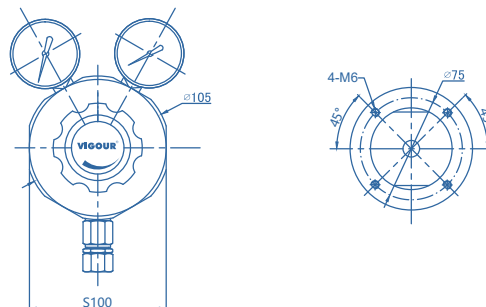
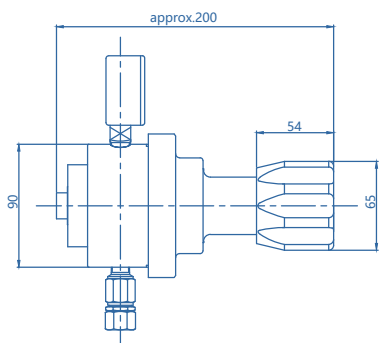

### Technical Data

Type:	single-stage
Inlet pressure P <sub>1</sub> :	max. 300 bar
Outlet pressure P <sub>2</sub> :	20/40/60 bar
Materials	
Body regulator, relief valve:	see ordering info
Valve seat:	PA66
Filter:	SS 316L
O-ring:	Viton® (FKM)
Inlets and Outlets:	see ordering info
Temperature range:	-30°C to +74°C
Leak rate	bubble-tight
Flow capacity:	C <sub>v</sub> =2.0
Weight:	5.5 kg

### Flow Chart

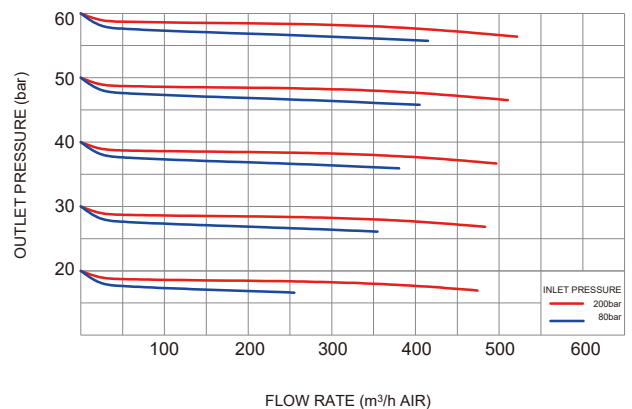

# Vielfältige Regulatoren / Manifold Regulators

## VSR-36 Series

### Ordering Information

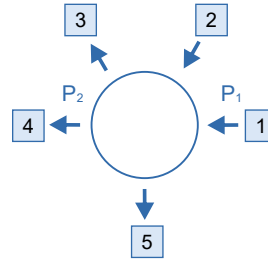

#### Inlets / Outlets

F4: 1/4"NPT(F) [gauge ports]  
 F6: 3/8"NPT(F)  
 F8: 1/2"NPT(F)  
 F12: 3/4"NPT(F)

P: Gauge (Psig/bar)  
 B: Plug  
 R: Relief valve

\* Other connection standard, consult factory.

#### Port Selection

VSR - 36S - 200 - 20 - 1 - 2 - 3 - 4 - 5 - N<sub>2</sub>

#### Body Material

S: 316L  
 C: chrome plated brass

#### Outlet Pressure P<sub>2</sub>

20: to 20 bar  
 40: to 40 bar  
 60: to 60 bar

#### Type of Gas

Please specify type of gas

#### Inlet Pressure P<sub>1</sub>

40: 40 bar  
 100: 100 bar  
 200: 200 bar  
 300: 300 bar

### Ordering Example

Example: VSR - 36S - 200 - 20 - F6 - P - P - F6 - B - N<sub>2</sub>

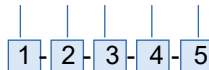

\* For mixed gases, please specify cylinder connection standard and thread when ordering.

# Hydrogen Pressure Regulator / Wasserstoffdruckregler

## VSR-9 Series

### Product Feature

- Piston-sensed design provides a long service life and enhanced safety
- High flow and minimal flow droop
- Balanced valve design minimizes supply pressure effect
- Used in diverse applications for a broad range of temperatures, flows, and pressures
- Wide variety of preset outlet pressures are available
- 10 micron, 316 Stainless Steel filter



### Typical Applications

- Hydrogen fuel cell vehicles

### Dimensions(mm)

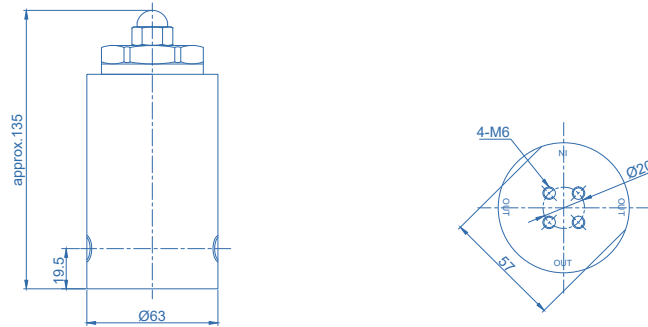

### Technical Data

Maximum Inlet Pressure	350 bar / 700 bar
Maximum Outlet Pressure	30 bar
<b>Materials</b>	
Body:	SS 316L / Aluminium
Seat:	Vespe <sup>®</sup>
O-Rings:	EPDM
Main Valve:	316 stainless steel
Sensor:	Aluminum 6061-T6
Spring:	302 stainless steel
Filter:	10 micron 316 stainless steel
Leakage	Bubble-tight
Operating Temperature	-40°F to 185°F (-40°C to 85°C)
Flow Capacity	Cv = 0.50
Weight:	2.4Kg

### Flowchart

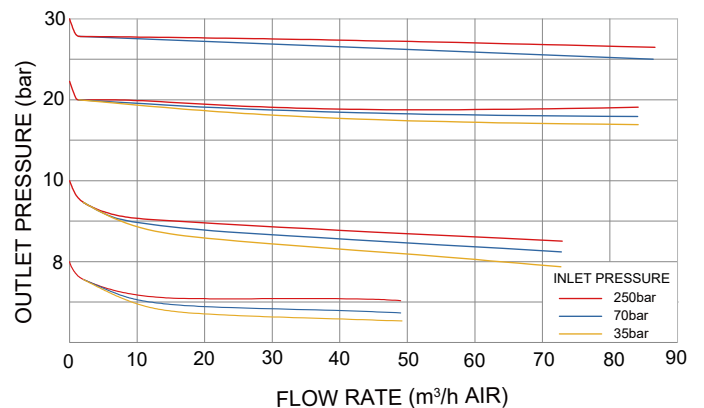

# Wasserstoffdruckregler / Hydrogen Pressure Regulator VSR-9 Series

## Ordering Information

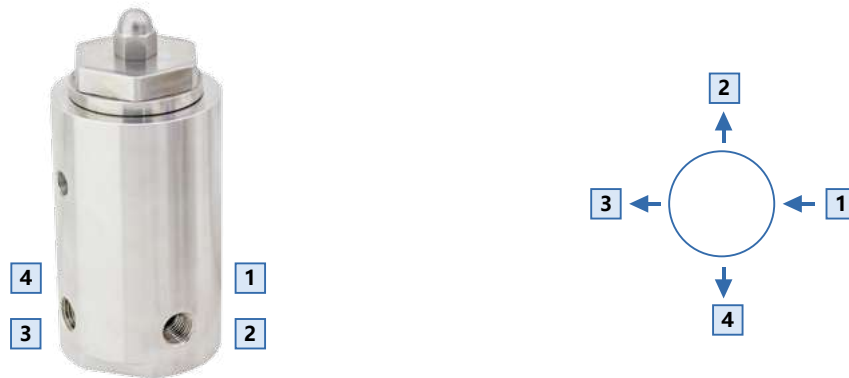

### Inlet/Outlet Connections

F4: 1/4" NPT(F)

F6: 3/8" NPT(F)

F8: 1/2" NPT(F)

A4: 1/4" SAE

A6: 3/8" SAE

A8: 1/2" SAE

P: gauge

\* Other connection standard, consult factory

### Port Selection

**VSR - 9S - 350 - 8 - 1 - 2 - 3 - 4**

#### Material

S: 316L

A: Aluminum

#### Inlet Pressure

350: 350 bar

700: 700 bar

#### Outlet Pressure

8: to 8 bar

10: to 10 bar

20: to 20 bar

30: to 30 bar

## Ordering Example

**VSR - 9S - 350 - 8 - F4 - F4 - F4 - F4**  
1 - 2 - 3 - 4





# Pressure Control Panels / Entspannungsstationen

## VSP-1E Series

### Product Features

- Pressure control panel
- VSR-1E VSR-6E series single-stage regulator
- Brass chrome plated body for inert, reactive, flammable and oxidizing gas and mixtures up to grade 6.0
- Stainless steel 316L body for corrosive gases
- Modular design
- Diaphragm type shut-off valves
- Suitable for inlet pressure up to 300 bar
- Easy installation into safety cabinet for gas cylinders
- Tested for use with oxygen



### Typical Applications

- Component Testing
- Calibration Systems
- Laboratory Pressure Control
- High Pressure Sampling Systems
- Service & Test Equipment

### Technical Data

Type:	single-stage
Inlet pressure P <sub>1</sub> :	max. 300 bar
Outlet pressure P <sub>2</sub> :	2/4/10/20/50/100/200 bar
Materials:	
Body regulator and valves:	see ordering info
Valve seat (regulator):	PCTFE
(shut-off valve):	PCTFE
Diaphragm (regulator):	Hastelloy® C276
(valve):	Elgiloy®
O-ring:	Viton® (FKM)
(option)	Kalrez® (FFKM)
Filter:	SS 316L
Temperature range:	-30°C to +74°C
Leak rate: (to atmosphere)	1x10 <sup>-8</sup> mbar l/s He
(via seat)	1x10 <sup>-6</sup> mbar l/s He
Weight:	3.3 kg

### Schematic Drawing

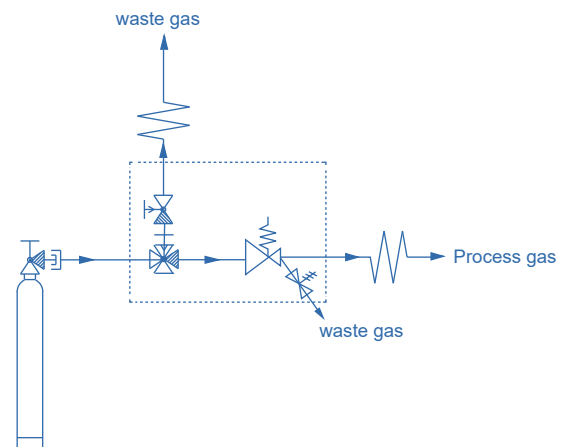

### Flow Chart

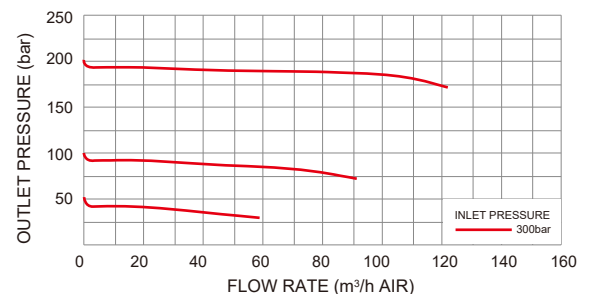
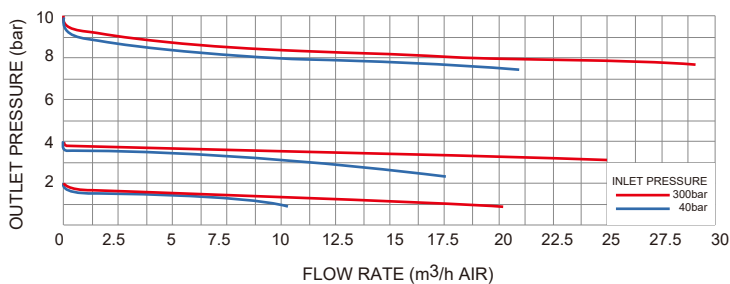

# Entspannungsstationen / Pressure Control Panels VSP-1E Series

## Dimensions (mm)

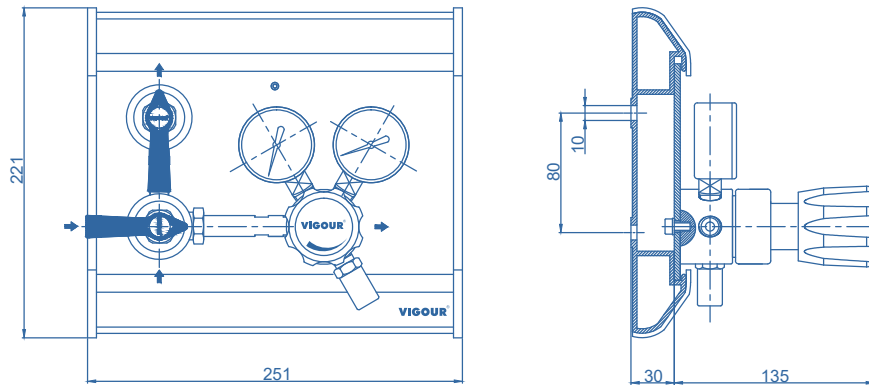

## Ordering Information:

**VSP - 1ES - 300 - 10 - P - P - V - N<sub>2</sub>**

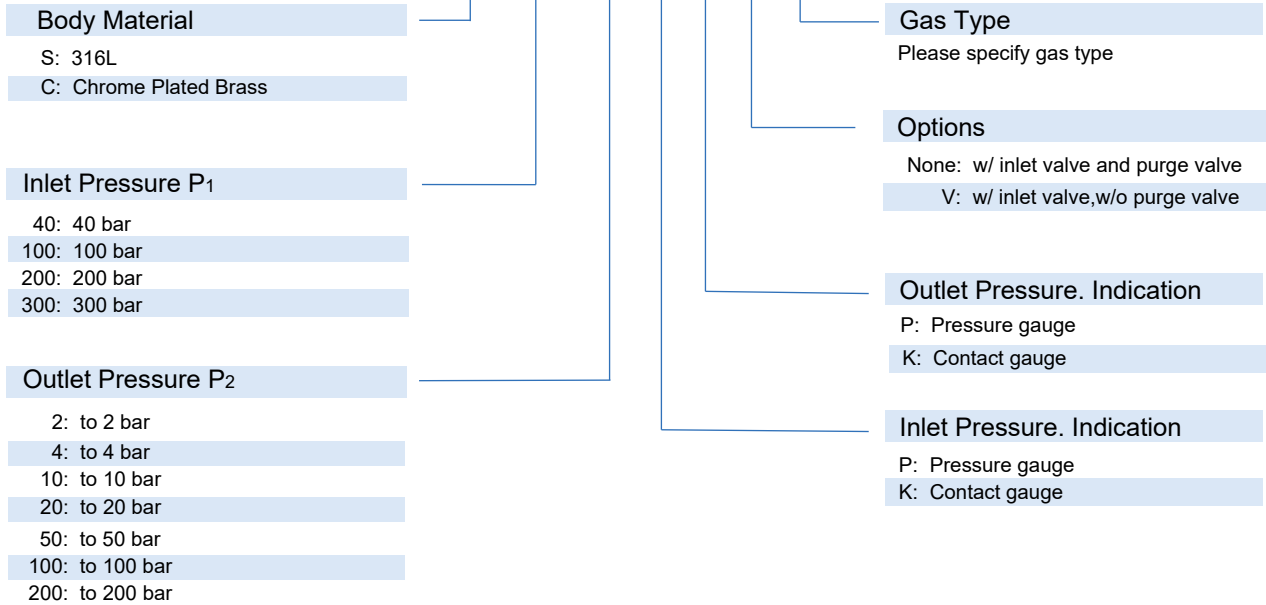

# Pressure Control Panels / Entspannungsstationen

## VSP-1 Series

### Product Features

- Pressure control panel
- VSR-2E series single-stage regulator
- Brass chrome plated body inert, reactive, flammable and oxidizing gas and mixtures up to grade 6.0
- Stainless steel 316L body for corrosive gases
- Modular design
- Diaphragm type shut-off valves
- Suitable for inlet pressure up to 300 bar
- Easy installation into safety cabinet for gas cylinders
- Tested for use with oxygen



### Typical Applications

- Component Testing
- Calibration Systems
- Laboratory Pressure Control
- High Pressure Sampling Systems
- Service & Test Equipment

### Technical Data

Type:	single-stage
Inlet pressure P <sub>1</sub> :	max. 300 bar
Outlet pressure P <sub>2</sub> :	2/4/10/20/35/50 bar
Materials:	
Body regulator and valves:	see ordering info
Valve seat (regulator):	PCTFE
(shut-off valve):	PCTFE
Diaphragm (regulator):	Hastelloy® C276
(valve):	Elgiloy®
O-ring:	Viton® (FKM)
(option)	Kalrez® (FFKM)
Filter:	SS 316L
Temperature range:	-30°C to +74°C
Leak rate: (to atmosphere)	1x10 <sup>-8</sup> mbar l/s He
(via seat)	1x10 <sup>-6</sup> mbar l/s He
Weight:	3.5 kg

### Schematic Drawing

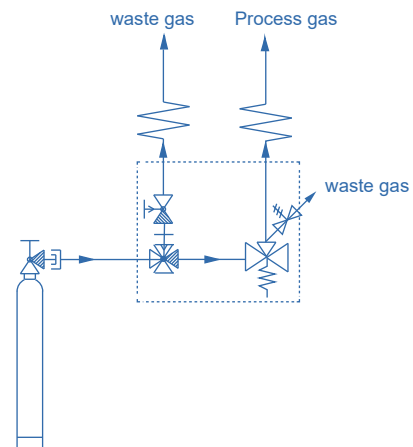

### Flow Chart

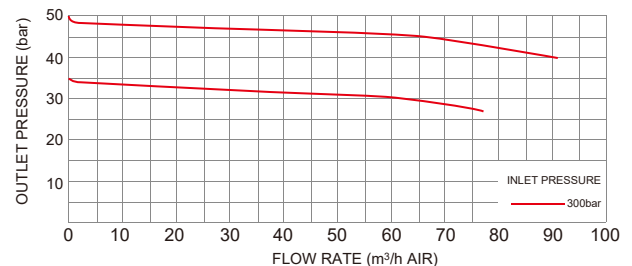
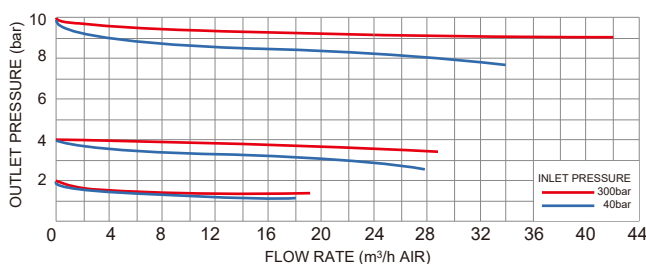

# Entspannungsstationen / Pressure Control Panels VSP-1 Series

## Dimensions (mm)

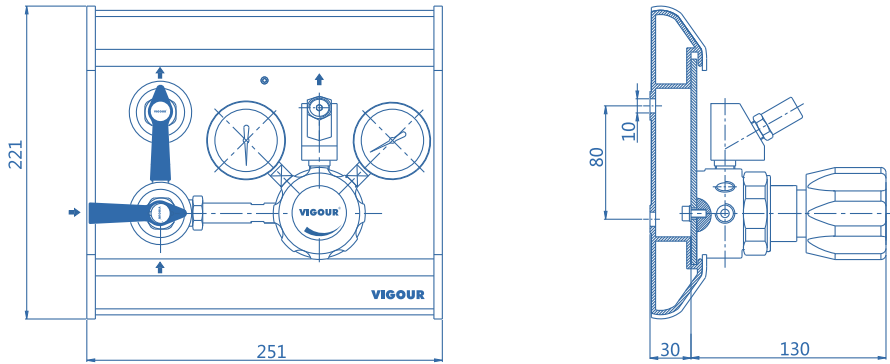

## Ordering Information:

**VSP - 1S - 300 - 10 - P - P - V - N<sub>2</sub>**

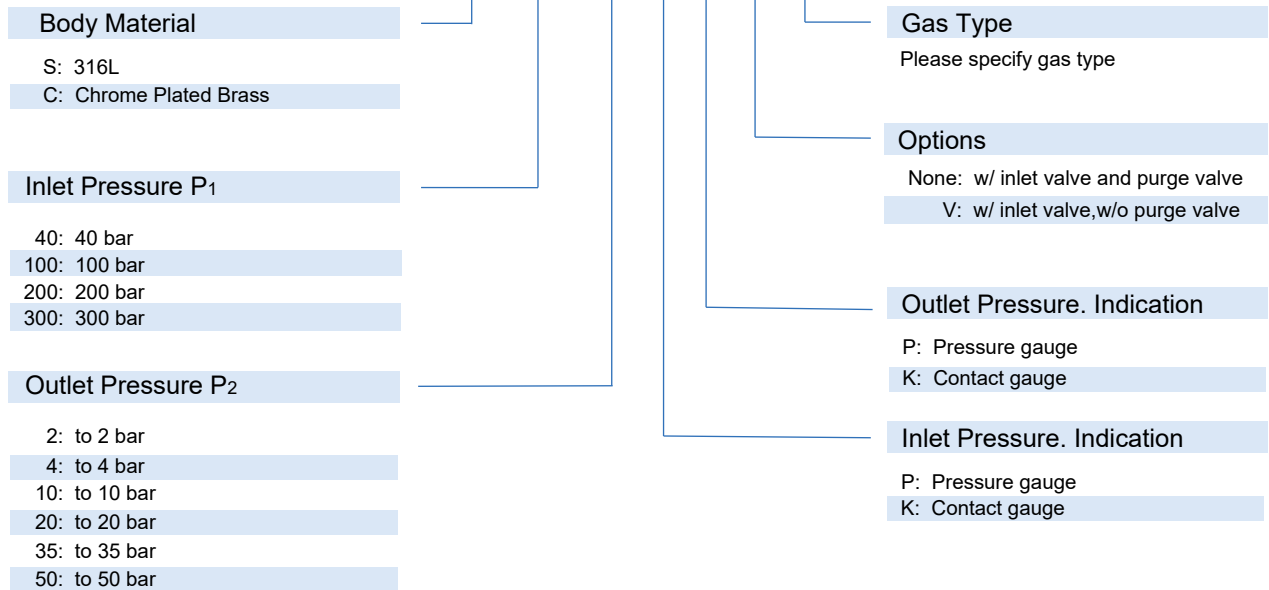

# Pressure Control Panels / Manuelle Umschaltstationen

## VSP-2E Series

### Product Features

- Pressure control panel
- VSR-1E VSR-6E series single-stage regulator
- Brass chrome plated body for inert, reactive, flammable and oxidizing gas and mixtures up to grade 6.0
- Stainless steel 316L body for corrosive gases
- Diaphragm type shut-off valves
- Modular design
- Suitable for inlet pressure up to 300 bar
- Easy installation into safety cabinet for gas cylinders
- Tested for use with oxygen



### Typical Applications

- Component Testing
- Calibration Systems
- Laboratory Pressure Control
- High Pressure Sampling Systems
- Service & Test Equipment

### Technical Data

Type:	single-stage
Inlet pressure P <sub>1</sub> :	max. 300 bar
Outlet pressure P <sub>2</sub> :	2/4/10/20/ 50/100/200 bar
<b>Materials:</b>	
Body regulator and valves:	see ordering info
Valve seat (regulator):	PCTFE
(shut-off valve):	PCTFE
Diaphragm (regulator):	Hastelloy® C276
(valve):	Elgiloy®
O-ring:	Viton® (FKM)
(option)	Kalrez® (FFKM)
Filter:	SS 316L
Temperature range:	-30°C to +74°C
Leak rate: (to atmosphere)	1x10 <sup>-8</sup> mbar l/s He
(via seat)	1x10 <sup>-6</sup> mbar l/s He
Weight:	4.5 kg

### Schematic Drawing

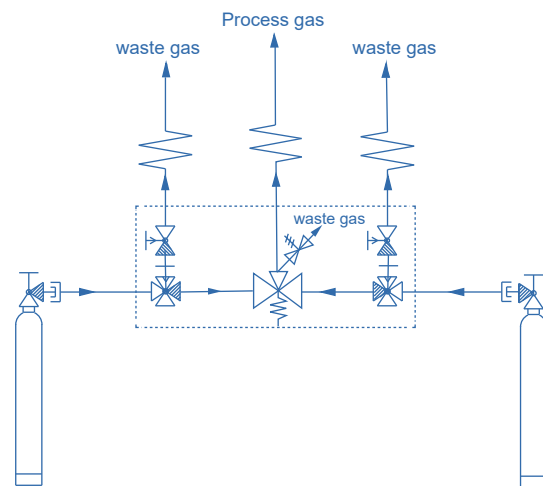

### Flow Chart

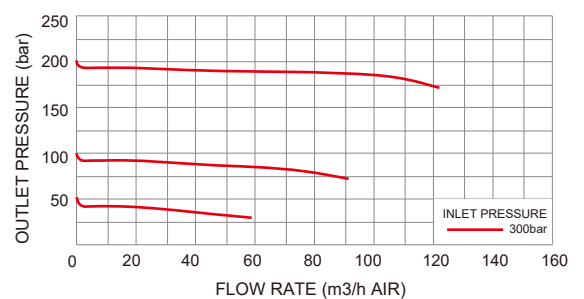
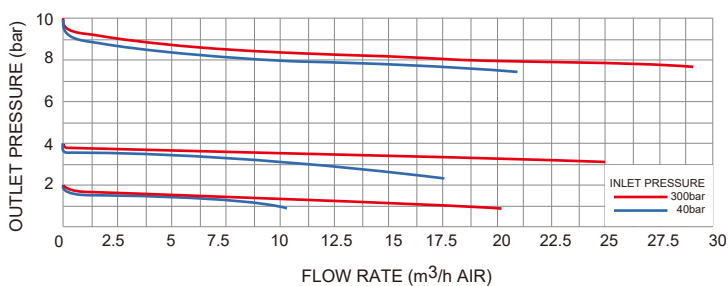

# Manuelle Umschaltstationen / Pressure Control Panels VSP-2E Series

## Dimensions (mm)

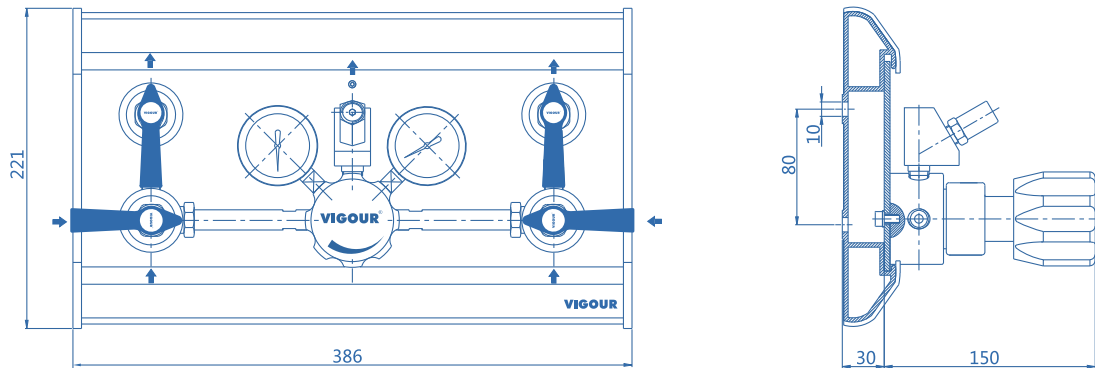

## Ordering Information:

**VSP - 2E S - 300 - 10 - P - P - V - N<sub>2</sub>**

### Body Material

- S: 316L
- C: Chrome Plated Brass

### Inlet Pressure P<sub>1</sub>

- 40: 40 bar
- 100: 100 bar
- 200: 200 bar
- 300: 300 bar

### Outlet Pressure P<sub>2</sub>

- 2: to 2 bar
- 4: to 4 bar
- 10: to 10 bar
- 20: to 20 bar
- 50: to 50 bar
- 100: to 100 bar
- 200: to 200 bar

### Gas Type

Please specify gas type

### Options

- None: w/ inlet valve and purge valve
- V: w/ inlet valve, w/o purge valve

### Outlet Pressure. Indication

- P: Pressure gauge
- K: Contact gauge

### Inlet Pressure. Indication

- P: Pressure gauge
- K: Contact gauge

# Pressure Control Panels / Manuelle Umschaltstationen

## VSP-2 Series

### Product Features

- Pressure control panel
- VSR-2E series single-stage regulator
- Brass chrome plated body for inert, reactive, flammable and oxidizing gas and mixtures up to grade 6.0
- Stainless steel 316L body for corrosive gases
- Modular design
- Diaphragm type shut-off valves
- Suitable for inlet pressure up to 300 bar
- Easy installation into safety cabinet for gas cylinders
- Tested for use with oxygen



### Typical Applications

- Component Testing
- Calibration Systems
- Laboratory Pressure Control
- High Pressure Sampling Systems
- Service & Test Equipment

### Technical Data

Type:	single-stage
Inlet pressure P <sub>1</sub> :	max. 300 bar
Outlet pressure P <sub>2</sub> :	2/4/10/20/35/50 bar
Materials:	
Body regulator and valves:	see ordering info
Valve seat (regulator):	PCTFE
(shut-off valve):	PCTFE
Diaphragm (regulator):	Hastelloy® C276
(valve):	Elgiloy®
O-ring:	Viton® (FKM)
(option)	Kalrez® (FFKM)
Filter:	SS 316L
Temperature range:	-30°C to +74°C
Leak rate: (to atmosphere)	1x10 <sup>-8</sup> mbar l/s He
(via seat)	1x10 <sup>-6</sup> mbar l/s He
Weight:	4.5 kg

### Schematic Drawing

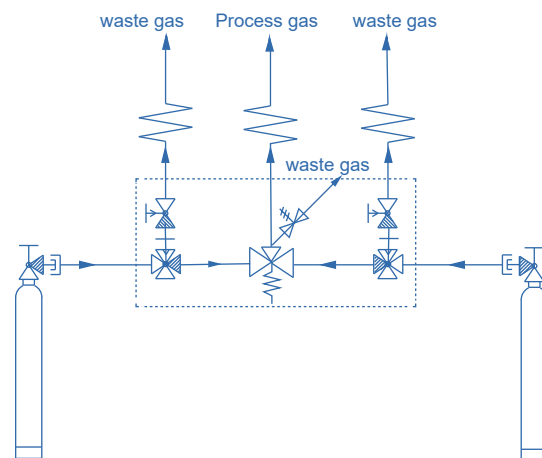

### Flow Chart

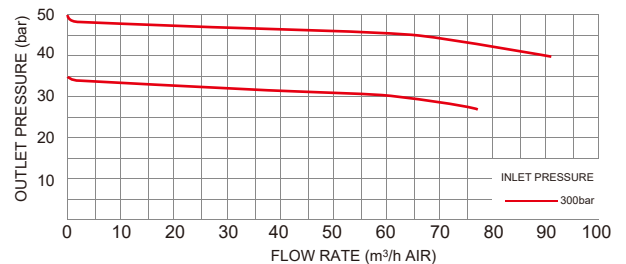
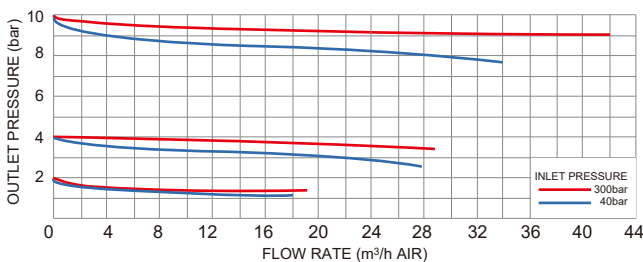

# Manuelle Umschaltstationen/Pressure Control Panels VSP-2 Series

## Dimensions (mm)

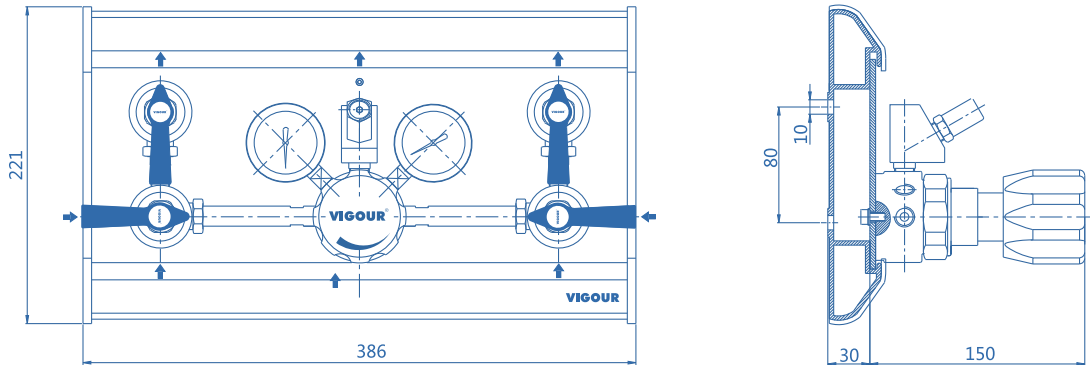

## Ordering Information:

**VSP - 2S - 300 - 10 - P - P - V - N<sub>2</sub>**

<p><b>Body Material</b></p> <p>S: 316L</p> <p>C: Chrome Plated Brass</p>	<p><b>Inlet Pressure P<sub>1</sub></b></p> <p>40: 40 bar</p> <p>100: 100 bar</p> <p>200: 200 bar</p> <p>300: 300 bar</p>	<p><b>Outlet Pressure P<sub>2</sub></b></p> <p>2: to 2 bar</p> <p>4: to 4 bar</p> <p>10: to 10 bar</p> <p>20: to 20 bar</p> <p>35: to 35 bar</p> <p>50: to 50 bar</p>	<p><b>Gas Type</b></p> <p>Please specify gas type</p>	<p><b>Options</b></p> <p>None: w/ inlet valve and purge valve</p> <p>V: w/ inlet valve, w/o purge valve</p>	<p><b>Outlet Pressure. Indication</b></p> <p>P: Pressure gauge</p> <p>K: Contact gauge</p>	<p><b>Inlet Pressure. Indication</b></p> <p>P: Pressure gauge</p> <p>K: Contact gauge</p>
--	--	---	---	---	--	---



# Pressure Control Panels - Automatic Change Over System

## VSP-3AE Series

Automatische Umschaltstationen (mit Spülung)

### Product Features

- Pressure control panels with automatic change-over function
- VSR-1E VSR-6E series single-stage regulator
- Brass chrome plated body and bonnet for inert, reactive, flammable and oxidizing gas and mixtures up to grade 6.0
- Stainless steel 316L body and bonnet for corrosive gases
- Diaphragm type shut-off valves
- Modular design
- Suitable for inlet pressure up to 300 bar
- Easy installation into safety cabinet for gas cylinders
- Tested for use with oxygen



### Typical Applications

- Component Testing
- Calibration Systems
- Laboratory Pressure Control
- High Pressure Sampling Systems
- Service & Test Equipment

### Technical Data

Type:	single-stage
Inlet pressure P <sub>1</sub> :	max. 300 bar
Outlet pressure P <sub>2</sub> :	2/4/10/20/50/100 bar
Materials:	
Body regulator and valves:	see ordering info
Valve seat (regulator):	PCTFE
(shut-off valve):	PCTFE
Diaphragm (regulator):	Hastelloy® C276
(valve):	Elgiloy®
O-ring:	Viton® (FKM)
(option)	Kalrez® (FFKM)
Filter:	SS 316L
Temperature range:	-30°C to +74°C
Leak rate: (to atmosphere)	1x10 <sup>-8</sup> mbar l/s He
(via seat)	1x10 <sup>-6</sup> mbar l/s He
Weight:	4.8 kg

### Schematic Drawing

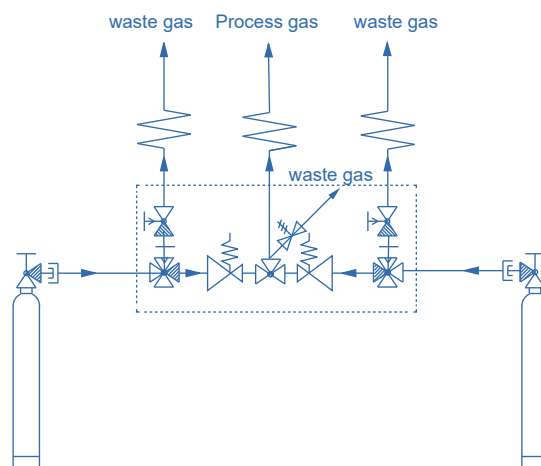

### Flow Chart

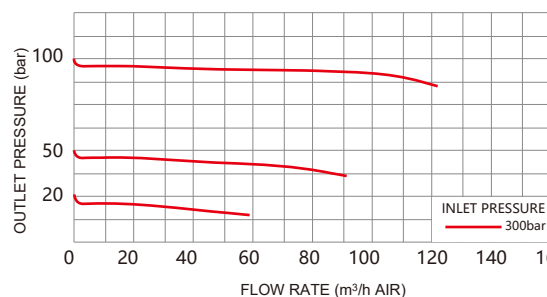
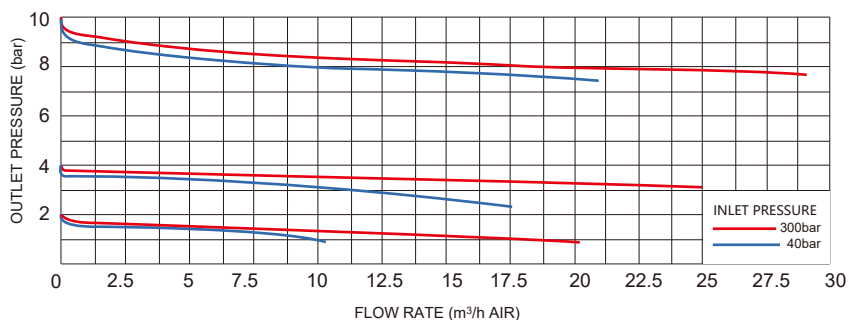

# Pressure Control Panels - Automatic Change Over System

## Automatische Umschaltstationen (mit Spülung) VSP-3AE Series

### Dimensions (mm)

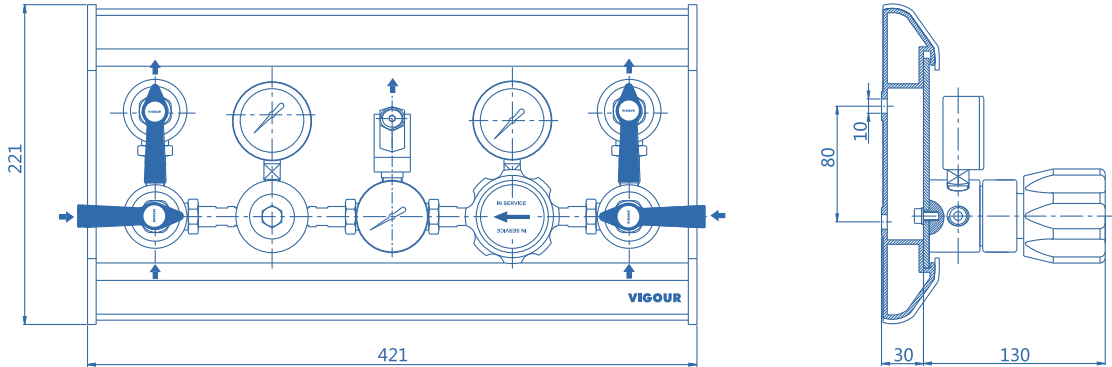

### Ordering Information

**VSP - 3AES - 300 - 10 - P - P - V - N<sub>2</sub>**

<p><b>Body Material</b></p> <p>S: 316L C: chrome plated brass</p>	<p><b>Inlet Pressure P<sub>1</sub></b></p> <p>40: 40 bar 100: 100 bar 200: 200 bar 300: 300 bar</p>	<p><b>Outlet Pressure P<sub>2</sub></b></p> <p>2: to 2 bar 4: to 4 bar 10: to 10 bar 20: to 20 bar 50: to 50 bar 100: to 100 bar</p>	<p><b>Gas Type</b></p> <p>Please specify gas type</p>	<p><b>Options</b></p> <p>None: w/ inlet valve and purge valve V: w/ inlet valve,w/o purge valve X: w/o inlet valve and purge valve</p>	<p><b>Outlet Pressure. Indication</b></p> <p>P: Pressure gauge K: Contact gauge</p>	<p><b>Inlet Pressure. Indication</b></p> <p>P: Pressure gauge K: Contact gauge</p>
---	---	--	---	--	---	--

# Pressure Control Panels - Automatic Change Over System

## VSP-6A Series

Automatische Umschaltstationen (mit Spülung)

### Product Features

- Pressure control panels with automatic change-over function
- VSR-3 series single-stage regulator
- Brass chrome plated body and bonnet for inert, reactive, flammable and oxidizing gas and mixtures up to grade 6.0
- Stainless steel 316L body and bonnet for corrosive gases
- Diaphragm type shut-off valves
- Modular design
- Suitable for inlet pressure up to 300 bar
- Easy installation into safety cabinet for gas cylinders
- Tested for use with oxygen



### Typical Applications

- Component Testing
- Calibration Systems
- Laboratory Pressure Control
- High Pressure Sampling Systems
- Service & Test Equipment

### Technical Data

Type:	single-stage
Inlet pressure P <sub>1</sub> :	max. 300 bar
Outlet pressure P <sub>2</sub> :	2/4/10/20 bar
Materials:	
Body regulator and valves:	see ordering info
Valve seat (regulator):	PCTFE
(shut-off valve):	PCTFE
Diaphragm (regulator):	Hastelloy® C276
(valve):	Elgiloy®
O-ring:	Viton® (FKM)
(option)	Kalrez® (FFKM)
Filter:	SS 316L
Temperature range:	-30°C to +74°C
Leak rate: (to atmosphere)	1x10 <sup>-8</sup> mbar l/s He
(via seat)	1x10 <sup>-6</sup> mbar l/s He
Weight:	6.8 kg

### Schematic Drawing

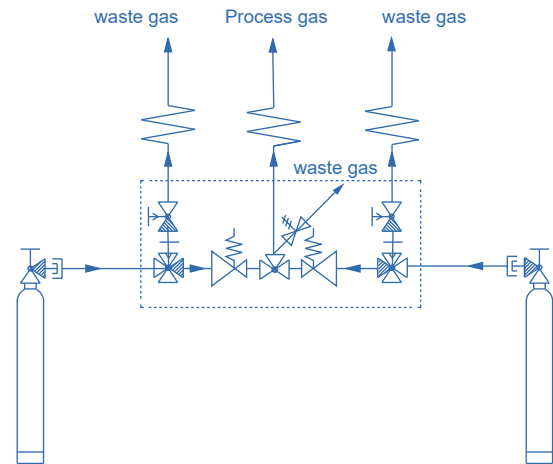

### Flow Chart

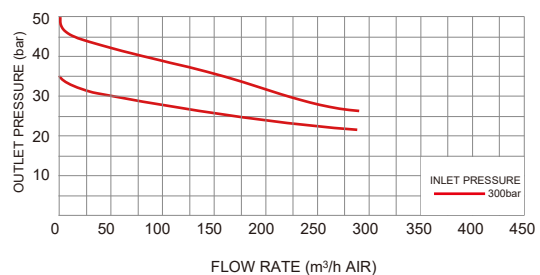
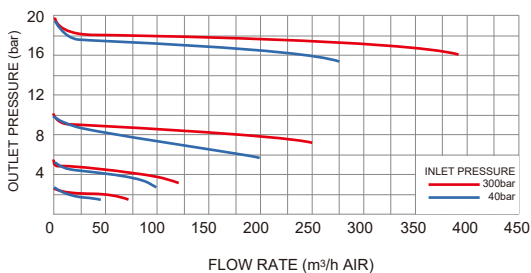

# Pressure Control Panels - Automatic Change Over System

## Automatische Umschaltstationen (mit Spülung) VSP-6A Series

### Dimensions (mm)

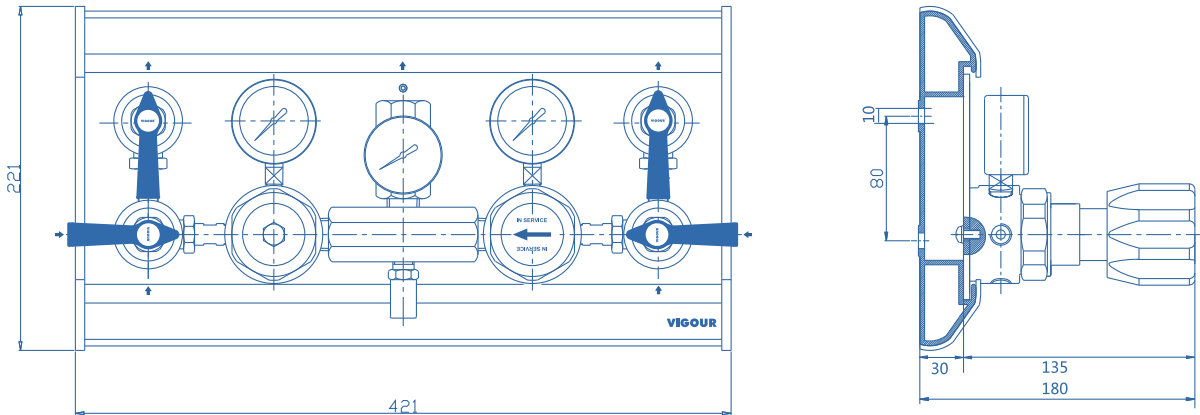

### Ordering Information

**VSP - 6AS - 300 - 10 - P - P - V - N<sub>2</sub>**

<p><b>Body Material</b></p> <p>S: 316L C: chrome plated brass</p>	<p><b>Inlet Pressure P<sub>1</sub></b></p> <p>40: 40 bar 100: 100 bar 200: 200 bar 300: 300 bar</p>	<p><b>Outlet Pressure P<sub>2</sub></b></p> <p>2: to 2 bar 4: to 4 bar 10: to 10 bar 20: to 20 bar 35: to 35 bar 50: to 50 bar</p>	<p><b>Gas Type</b></p> <p>Please specify gas type</p>	<p><b>Options</b></p> <p>None: w/ inlet valve and purge valve V: w/ inlet valve, w/o purge valve X: w/o inlet valve and purge valve</p>	<p><b>Outlet Pressure. Indication</b></p> <p>P: Pressure gauge K: Contact gauge</p>	<p><b>Inlet Pressure. Indication</b></p> <p>P: Pressure gauge K: Contact gauge</p>
---	---	--	---	---	---	--

# Pressure Control Panels - Automatic Change Over System

## VSP-8AE Series

Automatische Umschaltstationen (mit Spülung)

### Product Features

- Double-side pressure control panel
- VSR-1E / VSR-6E series single-stage regulator
- Brass chrome plated body and bonnet for inert, reactive, flammable and oxidizing gas and mixtures up to grade 6.0
- Stainless steel 316L body and bonnet for corrosive gases
- Equipped with exhaust gas purge diaphragm valve and inlet diaphragm valve, easy to operate
- Modular design
- Suitable for inlet pressure up to 300 bar
- Easy installation into safety cabinet for gas cylinders
- Tested for use with oxygen



### Typical Applications

- Component Testing
- Calibration Systems
- Laboratory Pressure Control
- High Pressure Sampling Systems
- Service & Test Equipment

### Technical Data

Type:	single-stage
Inlet pressure P <sub>1</sub> :	max. 300 bar
Outlet pressure P <sub>2</sub> :	2/4/10/20/50/100 bar
Materials:	
Body regulator and valves:	see ordering info
Valve seat (regulator):	PCTFE
(shut-off valve):	PCTFE (VDV30)
Diaphragm (regulator):	Hastelloy® C276
(valve):	Elgiloy®
O-ring:	Viton® (FKM)
(option)	Kalrez® (FFKM)
Filter:	SS 316L
Panel:	Aluminium
Temperature range:	-30°C to +74°C
Leak rate: (to atmosphere)	1x10 <sup>-8</sup> mbar l/s He
(via seat)	1x10 <sup>-6</sup> mbar l/s He
Weight:	4.8 kg

### Schematic Drawing

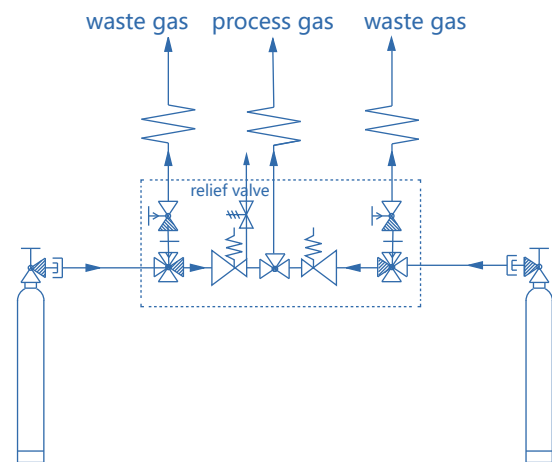

### Flow Chart

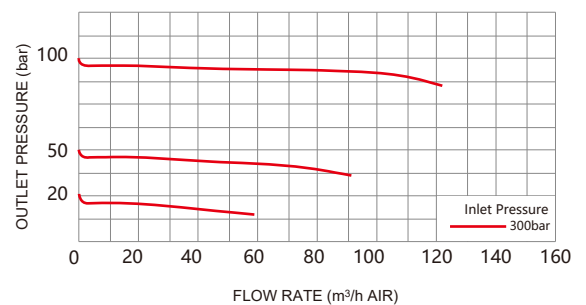
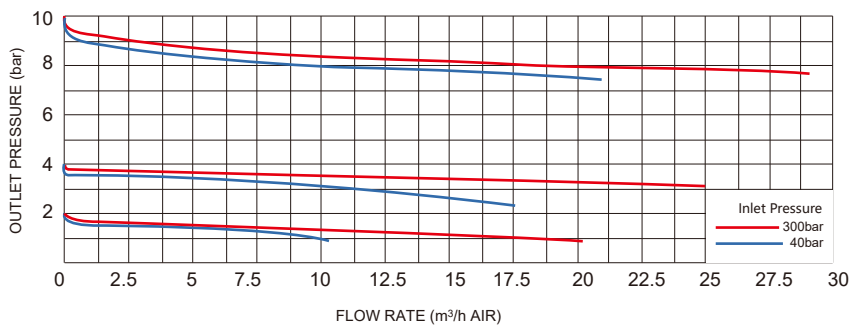

# Pressure Control Panels - Automatic Change Over System

## Automatische Umschaltstationen (mit Spülung)

### VSP-8AE Series

#### Dimensions (mm)

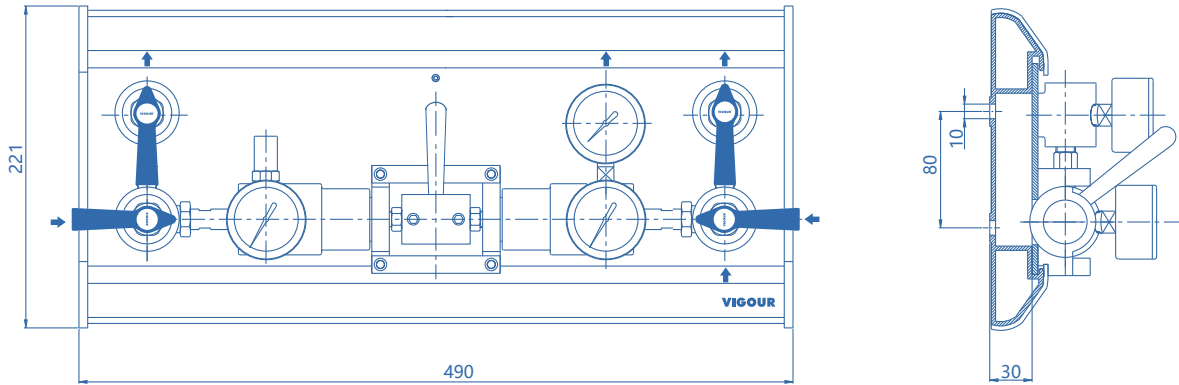

#### Ordering Information

**VSP - 8AES - 300 - 10 - P - P - X - N<sub>2</sub>**

##### Body Material

S: 316L

C: chrome plated brass

##### Inlet Pressure P<sub>1</sub>

40: 40 bar

100: 100 bar

200: 200 bar

300: 300 bar

##### Outlet Pressure P<sub>2</sub>

2: to 2 bar

4: to 4 bar

10: to 10 bar

20: to 20 bar

50: to 50 bar

100: to 100 bar

##### Gas Type

Please specify gas type

##### Options

None: w/ inlet valve and purge valve

V: w/ inlet valve, w/o purge valve

##### Outlet Pressure. Indication

P: Pressure gauge (Psig/Bar)

K: Contact gauge (Psig/Bar)

##### Inlet Pressure. Indication

P: Pressure gauge (Psig/Bar)

K: Contact gauge (Psig/Bar)

# Pressure Control Panels - Automatic Change Over System

## VSP-11E Series

Automatische Umschaltstationen (mit Spülung)

### Product Features

- Pressure control panels with automatic change-over function
- VSR-1E series double stage regulator
- Brass chrome plated body and bonnet for inert, reactive, flammable and oxidizing gas and mixtures up to grade 6.0
- Stainless steel 316L body and bonnet for corrosive gases
- Diaphragm type shut-off valves
- Modular design
- Suitable for inlet pressure up to 300 bar
- Easy installation into safety cabinet for gas cylinders
- Tested for use with oxygen



### Typical Applications

- Component Testing
- Calibration Systems
- Laboratory Pressure Control
- High Pressure Sampling Systems
- Service & Test Equipment

### Technical Data

Type:	double stage
Inlet pressure P <sub>1</sub> :	max. 300 bar
Outlet pressure P <sub>2</sub> :	2/4/10/20 bar
Materials:	
Body regulator and valves:	see ordering info
Valve seat (regulator):	PCTFE
(shut-off valve):	PCTFE
Diaphragm (regulator):	Hastelloy® C276
(valve):	Elgiloy®
O-ring:	Viton® (FKM)
(option)	Kalrez® (FFKM)
Filter:	SS 316L
Temperature range:	-30°C to +74°C
Leak rate: (to atmosphere)	1x10 <sup>-8</sup> mbar l/s He
(via seat)	1x10 <sup>-6</sup> mbar l/s He
Weight:	5.1 kg

### Schematic Drawing

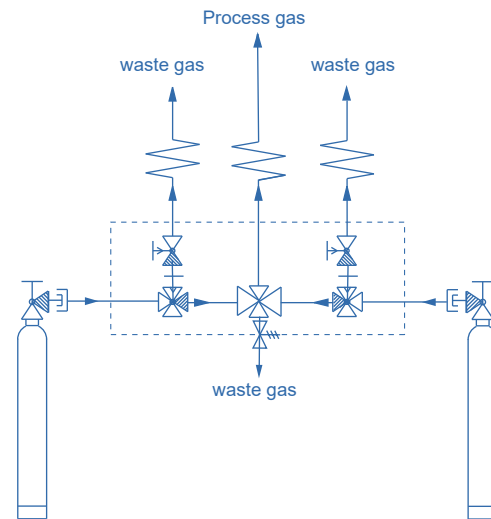

### Flow Chart

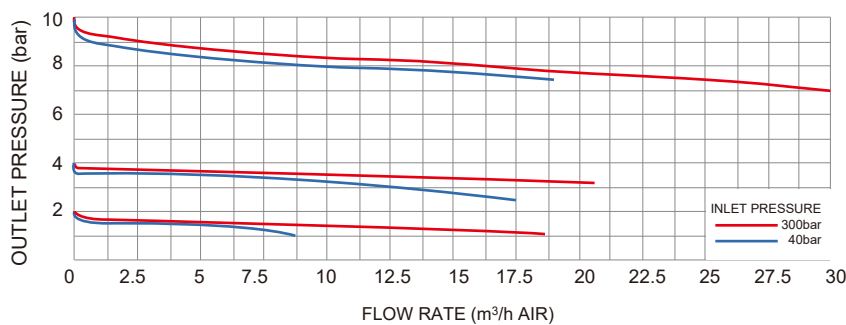

# Pressure Control Panels - Automatic Change Over System

## Automatische Umschaltstationen (mit Spülung) VSP-11E Series

### Dimensions (mm)

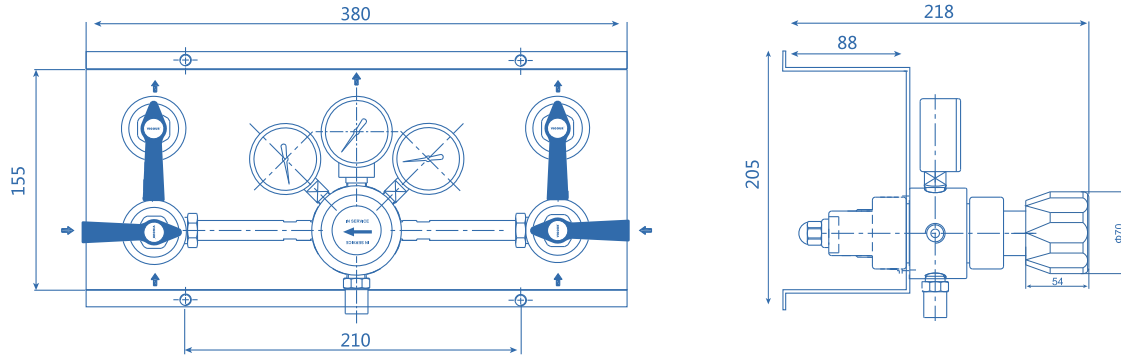

### Ordering Information

**VSP - 11S - 200 - 10 - P - P - V - N<sub>2</sub>**

<p><b>Body Material</b></p> <p>S: 316L C: Chrome Plated Brass</p>	<p><b>Inlet Pressure P<sub>1</sub></b></p> <p>40: 40 bar 100: 100 bar 200: 200 bar 300: 300 bar</p>	<p><b>Outlet Pressure P<sub>2</sub></b></p> <p>2: to 2 bar 4: to 4 bar 10: to 10 bar 20: to 20 bar</p>	<p><b>Type Of Gas</b></p> <p>Please specify gas type</p>	<p><b>Options</b></p> <p>None: w/ inlet valve and purge valve V: w/ inlet valve, w/o purge valve</p>	<p><b>Outlet Pressure. Indication</b></p> <p>P: Pressure gauge K: Contact gauge</p>	<p><b>Inlet Pressure. Indication</b></p> <p>P: Pressure gauge K: Contact gauge</p>
---	---	--	--	--	---	--



# Automatic Change Over System VSP-36 Series

## Product Feature

- Double-sided pressure control panels with automatic change-over function for high flow rates
- For non-corrosive technical gases
- Single-stage type with balanced main valve
- Modular design(to be extended to 2x2,2x3 etc. cylinders/ bundles)
- Central filter in the regulator
- Regulator with high control accuracy and integrated relief valve
- Shut-off valves
- Process gas and purge valve on the inlet pressure side
- Safety pressure gauges
- Designed for use with oxygen
- Suitable for inlet pressure values of up to 300 bar
- Adjustable outlet pressure



VSP-36C

## Flowchart

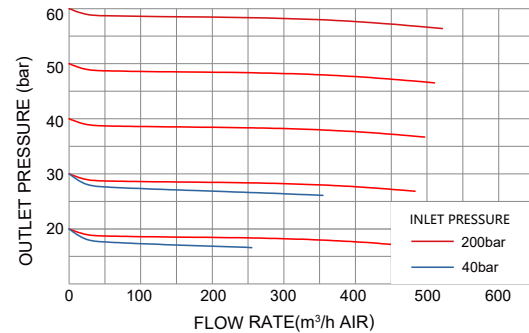
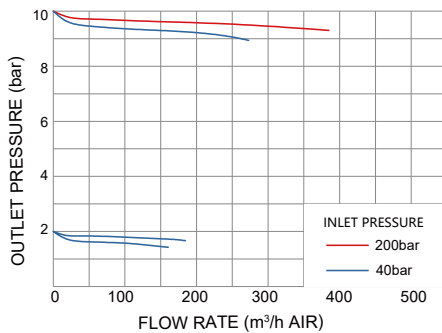

## Technical Data

Type	single-stage
Inlet pressure P1	max. 245 bar(brass) 300 bar(316L)
Outlet pressure P2	20 / 40 / 60 bar
Materials	
Shut-off valve :	Brass/chrome plated brass or 316L
Regulator body:	Brass/chrome plated brass or 316L
Regulator valve seat:	PA66
Filter :	Stainless steel
Mounting plates:	Stainless steel
O ring:	Viton® (FKM) standard Kalrez® (FFKM) option
Inlets	1/4" NPT(F)
Outlet	3/4" NPT (20mm stainless steel tube)
Temperature range	-30°C to +74°C
Leak rate	bubble tight
Weight	27.5 kg(brass) / 20 kg(316L)

## Schematic Drawing

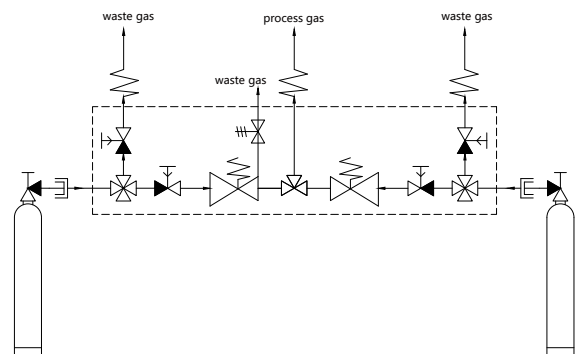

# Automatic Change Over System VSP-36 Series

## Dimensions(mm)

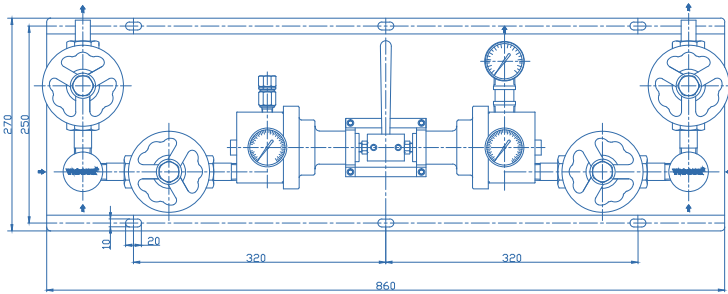

VSP-36B/C

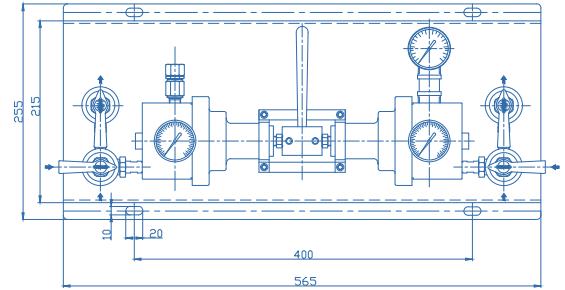

VSP-36S

## Ordering Information

**VSP - 36B - 200 - 20 - P - P - V - N<sub>2</sub>**

### Materials

- S: 316L
- B: Brass
- C: Chrome plated brass

### Inlet Pressure

- 40: 40 bar
- 100: 100 bar
- 200: 200 bar
- 300: 300 bar

### Outlet Pressure

- 20: 20 bar
- 40: 40 bar
- 60: 60 bar

### Gas Type

please specify gas type

### Options

- (None): w/ inlet valve and purge valve
- V: w/ inlet valve, w/o purge valve

### Outlet Gauge

- P: gauge
- K: contact gauge

### Inlet Gauge

- P: gauge
- K: contact gauge

# Pressure Control Panels - Automatic Change Over System

## VSP-5A Series

Automatische Umschaltstationen (mit Spülung)

### Product Features

- Pressure control panels with automatic change-over function
- VSR-1 / VSR-1E series single-stage regulator
- Brass chrome plated body and bonnet for inert, reactive, flammable and oxidizing gas and mixtures up to grade 6.0
- Stainless steel 316L body and bonnet for corrosive gases
- Modular design
- Suitable for inlet pressure up to 300 bar
- Compact design for easy installation into safety cabinets
- Tested for use with oxygen

### Typical Applications

- Component Testing
- Calibration Systems
- Laboratory Pressure Control
- High Pressure Sampling Systems
- Service & Test Equipment



### Technical Data

Type:	single-stage
Inlet pressure P <sub>1</sub> :	max. 300 bar
Outlet pressure P <sub>2</sub> :	2/4/10/20/35/50 bar
Materials:	
Body regulator	see ordering info
Valve seat (regulator):	PCTFE
Diaphragm (regulator):	Hastelloy® C276
Filter:	SS 316L
Temperature range:	-30°C to +74°C
Leak rate: (to atmosphere)	1x10 <sup>-8</sup> mbar l/s He
(via seat)	1x10 <sup>-6</sup> mbar l/s He
Weight:	12.1 kg

### Schematic Drawing

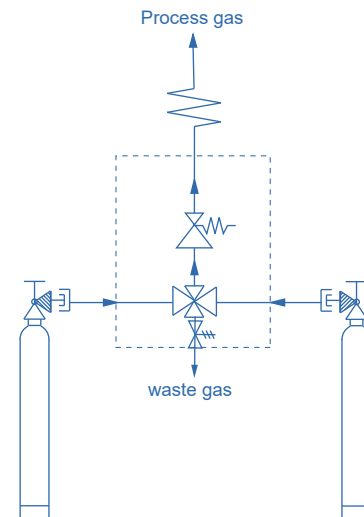

### Flow Chart

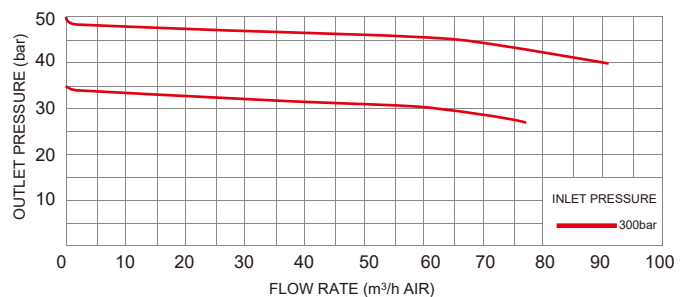
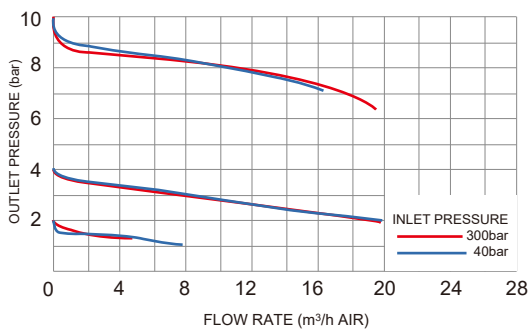

# Pressure Control Panels - Automatic Change Over System

## Automatische Umschaltstationen (mit Spülung)

### VSP-5A Series

#### Dimensions (mm)

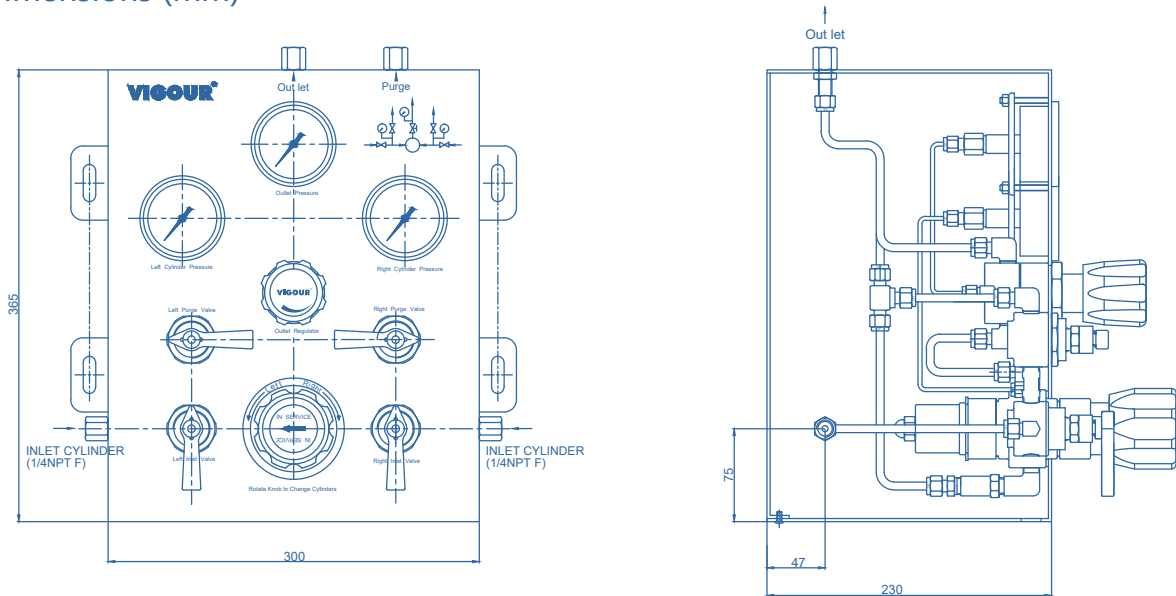

#### Ordering Information

**VSP - 5AS - 200 - 10 - 00 - 00 - V - N<sub>2</sub>**

##### Body Material

S: 316L

C: Chrome Plated Brass

##### Inlet Pressure P<sub>1</sub>

40: 40 bar

100: 100 bar

200: 200 bar

300: 300 bar

##### Outlet Pressure P<sub>2</sub>

2: to 2 bar

4: to 4 bar

10: to 10 bar

20: to 20 bar

35: to 35 bar

50: to 50 bar

##### Type Of Gas

Please specify gas type

##### Options

(None): w/ inlet valve and purge valve

V: w/ inlet valve, w/o purge valve

X: w/o inlet valve and purge valve

##### Outlet Connection

06: 3/8" Tube fitting(standard)

##### Inlet Connection

F4: 1/4"NPT(F)(standard)

M4: 1/4"NPT(M)

# Generator Back-up Panel / Generator-Absicherungspanel

## VSP-B Series

### Product Features

- Wall-mounting generator backup panel
- Design for backup application in Air, N<sub>2</sub>, H<sub>2</sub> generator
- Modular design
- Diaphragm type shut-off valves
- Standard c/w 1 set of 36" pigtail and integral check valve

### Typical Applications

- Component Testing
- Calibration Systems
- Laboratory Pressure Control
- High Pressure Sampling Systems
- Service & Test Equipment



### Technical Data

Type:	single-stage
Inlet pressure P <sub>1</sub> :	max. 300 bar
Materials:	
Body regulator and valves:	see ordering info
Valve seat (regulator):	PCTFE
(shut-off valve):	PCTFE
Diaphragm (regulator):	Hastelloy® C276
(valve):	Elgiloy®
O-ring:	Viton® (FKM)
(option)	Kalrez® (FFKM)
Filter:	SS 316L
Temperature range:	-30°C to +74°C
Leak rate: (to atmosphere)	1x10 <sup>-8</sup> mbar l/s He
(via seat)	1x10 <sup>-6</sup> mbar l/s He
Flow capacity:	Cv=0.08
Weight:	2.5 kg

### Schematic Drawing

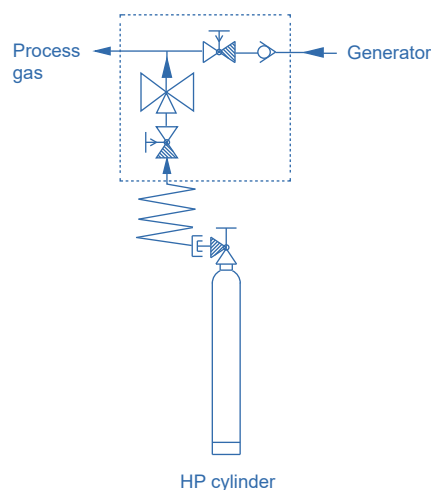

### Flow Chart

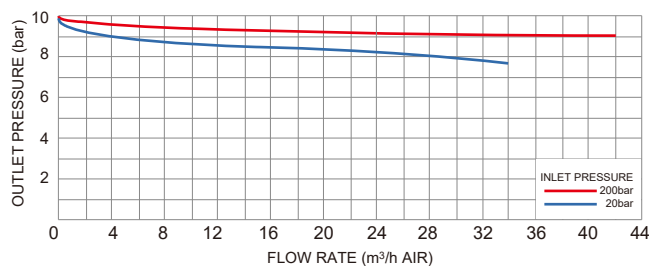

# Generator-Absicherungspanel / Generator Back-up Panel VSP-B Series

## Dimensions (mm)

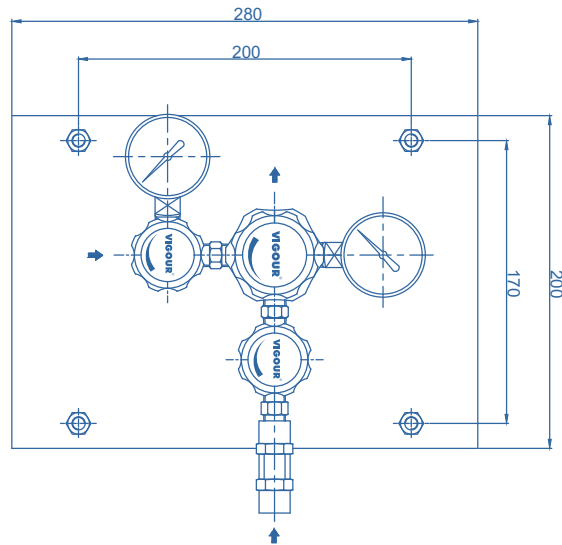

## Ordering Information:

**VSP - BS - 200 - 10 - N2**

### Body Material

S: 316L

C: Chrome Plated Brass

### Cylinder Pressure

200: 200 bar

300: 300 bar - with VDV30 (lever handle)

### Gas Type

Please specify gas type

### Outlet Pressure P<sub>2</sub>

10: to 10 bar

# Tapping Points / Entnahmestellen

## VSR-1ET Series

### Product Features

- Wall-mounting tapping points
- VSR-1EL series single-stage regulator
- Brass chrome plated body and bonnet for inert, reactive, flammable and oxidizing gas and mixtures up to grade 6.0
- Stainless steel 316L body and bonnet for corrosive gases
- Modular design
- Diaphragm type shut-off valves
- Suitable for inlet pressure up to 100 bar
- Tested for use with oxygen

### Typical Applications

- Component Testing
- Calibration Systems
- Laboratory Pressure Control
- High Pressure Sampling Systems
- Service & Test Equipment

### Technical Data

Type:	single-stage
Inlet pressure P <sub>1</sub> :	max. 100 bar
Outlet pressure P <sub>2</sub> :	2/4/10/20/50 bar
Materials:	
Body regulator and valves:	see ordering info
Valve seat (regulator):	PCTFE
(shut-off valve):	PEEK
Diaphragm(regulator):	Hastelloy® C276
(valve):	Hastelloy® C276
Filter:	SS 316L
Temperature range:	-30°C to +74°C
Leak rate (to atmosphere):	1x10 <sup>-8</sup> mbar l/s He
(via seat):	1x10 <sup>-6</sup> mbar l/s He
Flow capacity:	Cv=0.07
Weight:	2.5 kg



“A” type

“B” type

### Schematic Drawing

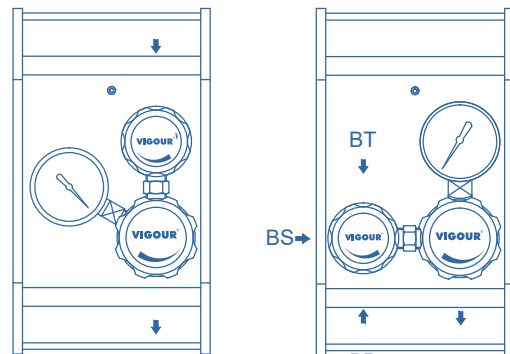

“A” type:  
Top-inlet

“B” type:  
Top-inlet ; Bottom-inlet ; Side-inlet

### Flow Chart

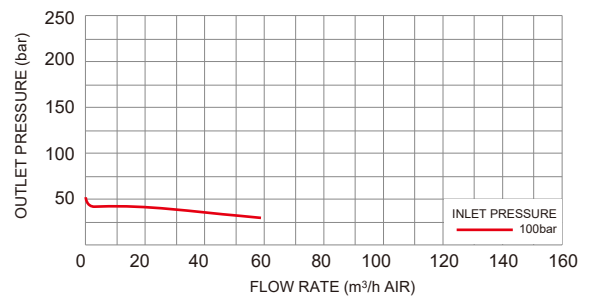
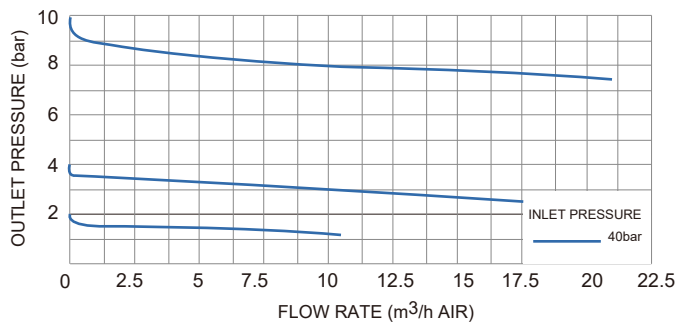

# Entnahmestellen / Tapping Points VSR-1ET Series

## Dimensions (mm)

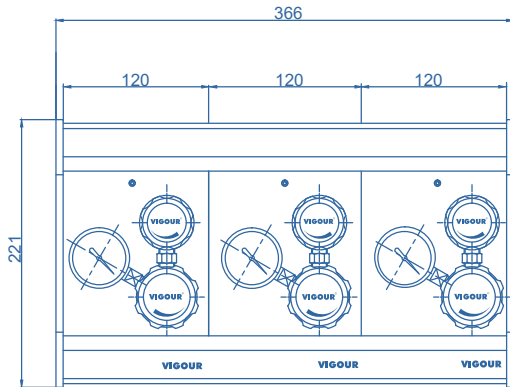

"A" type

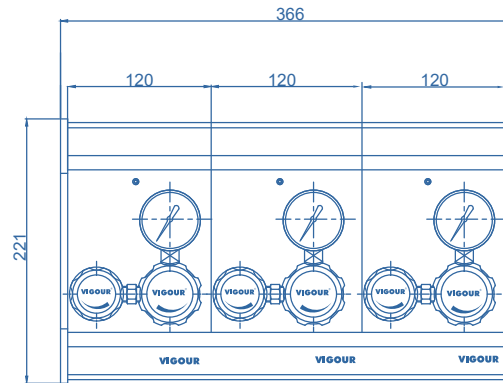

"B" type

## Ordering Information:

**VSR - 1ETS - 100 - 10 - AT - N<sub>2</sub>**

### Body Material

S: 316L

C: Chrome Plated Brass

### Inlet Pressure P<sub>1</sub>

40: 40 bar

100: 100 bar

### Outlet Pressure P<sub>2</sub>

2: to 2 bar

4: to 4 bar

10: to 10 bar

20: to 20 bar

50: to 50 bar

### Gas Type

Please specify gas type

### Inlet Type

AT: "A" Type Top-inlet

BT: "B" Type Top-inlet

BB: "B" Type Bottom-inlet

BS: "B" Type Side-inlet



# Tapping Points / Entnahmestellen

## VSR-2T Series

### Product Features

- Wall-mounting tapping points
- VSR-2EL series single-stage regulator
- Brass chrome plated body for inert, reactive, flammable and oxidizing gas and mixtures up to grade 6.0
- Stainless steel 316L body for corrosive gases
- Modular design
- Diaphragm type shut-off valves
- Suitable for inlet pressure up to 100 bar
- Tested for use with oxygen

### Typical Applications

- Component Testing
- Calibration Systems
- Laboratory Pressure Control
- High Pressure Sampling Systems
- Service & Test Equipment

### Technical Data

Type:	single-stage
Inlet pressure P <sub>1</sub> :	max. 100 bar
Outlet pressure P <sub>2</sub> :	2/4/10/20/35/50 bar
Materials:	
Body regulator and valves:	see ordering info
Valve seat (regulator):	PCTFE
(shut-off valve):	PEEK
Diaphragm (regulator):	Hastelloy® C276
(valve):	Hastelloy® C276
O-ring:	Viton® (FKM)
(option)	Kalrez® (FFKM)
Filter:	SS 316L
Temperature range:	-30°C to +74°C
Leak rate (to atmosphere):	1x10 <sup>-8</sup> mbar l/s He
(via seat):	1x10 <sup>-6</sup> mbar l/s He
Flow capacity:	
(Outlet pressure:2/4/10/20 bar)	C <sub>v</sub> =0.28
(Outlet pressure:35/50 bar)	C <sub>v</sub> =0.08
Weight:	3.5 kg



“A” type

“B” type

### Schematic Drawing

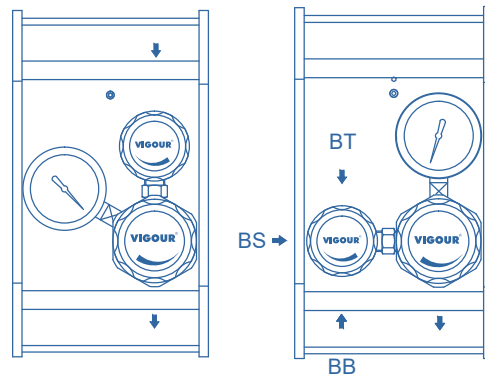

“A” Type:  
Top-inlet

“B” Type:  
Top-inlet ; Bottom-inlet ; Side-inlet

### Flow Chart

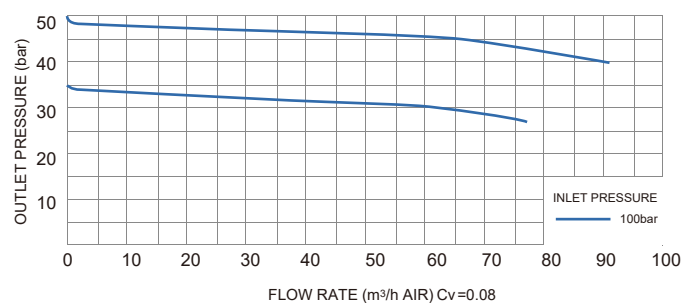
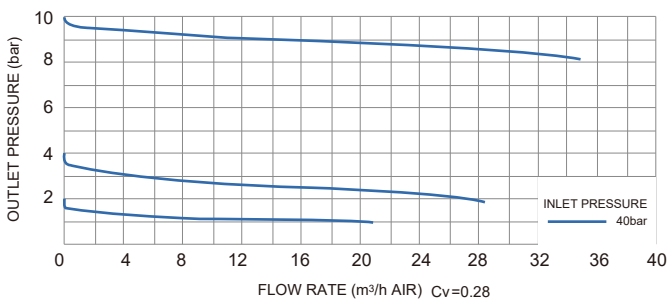

# Entnahmestellen / Tapping Points VSR-2T Series

## Dimensions (mm)

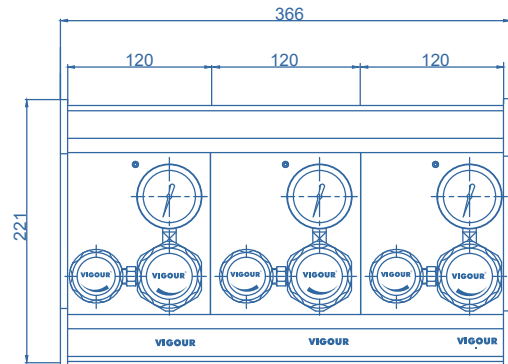
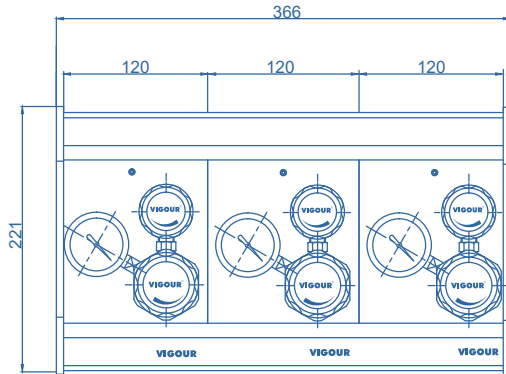

## Ordering Information:

**VSR - 2TS - 100 - 10 - AT - N<sub>2</sub>**

### Body Material

S: 316L

C: Chrome Plated Brass

### Inlet Pressure P<sub>1</sub>

40: 40 bar

100: 100 bar

### Outlet Pressure P<sub>2</sub>

2: to 2 bar

4: to 4 bar

10: to 10 bar

20: to 20 bar

35: to 35 bar

50: to 50 bar

### Gas Type

Please specify gas type

### Inlet Type

AT: "A" Type Top-inlet

BT: "B" Type Top-inlet

BB: "B" Type Bottom-inlet

BS: "B" Type Side-inlet

# Tapping Points / Entnahmestellen

## VSR-1ETG Series

### Product Features

- Wall-mounting tapping points
- VSR-1EL series single-stage regulator
- Brass chrome plated body and bonnet for inert, reactive, flammable and oxidizing gas and mixtures up to grade 6.0
- Stainless steel 316L body and bonnet for corrosive gases
- Modular design
- Diaphragm type shut-off valves
- Suitable for inlet pressure up to 100 bar
- Tested for use with oxygen

### Typical Applications

- Component Testing
- Calibration Systems
- Laboratory Pressure Control
- High Pressure Sampling Systems
- Service & Test Equipment



### Technical Data

Type:	single-stage
Inlet pressure P <sub>1</sub> :	max. 100 bar
Outlet pressure P <sub>2</sub> :	2/4/10/20/50 bar
<b>Materials:</b>	
Body regulator and valves:	see ordering info
Valve seat (regulator):	PCTFE
(shut-off valve):	PEEK
Diaphragm(regulator):	Hastelloy® C276
(valve):	Hastelloy® C276
Filter:	SS 316L
Temperature range:	-30°C to +74°C
Leak rate: (to atmosphere)	1x10 <sup>-8</sup> mbar l/s He
(via seat)	1x10 <sup>-6</sup> mbar l/s He
Flow capacity:	Cv=0.07
Weight:	4.1 ~ 5.7 kg

### Schematic Drawing

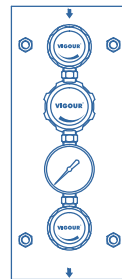

"A" Type:  
Single outlet

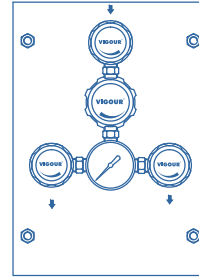

"B" Type:  
Dual outlet

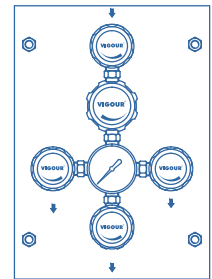

"C" Type:  
Triple outlet

### Flow Chart

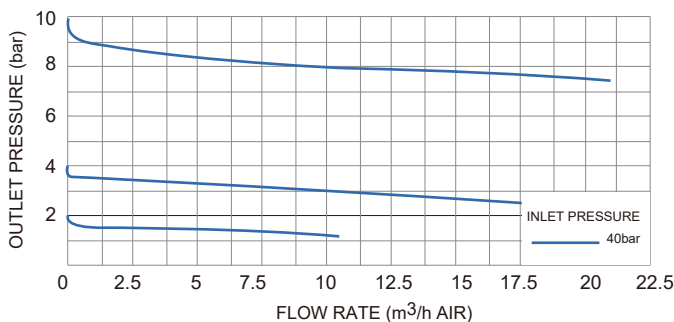

# Entnahmestellen / Tapping Points VSR-1ETG Series

## Dimensions (mm)

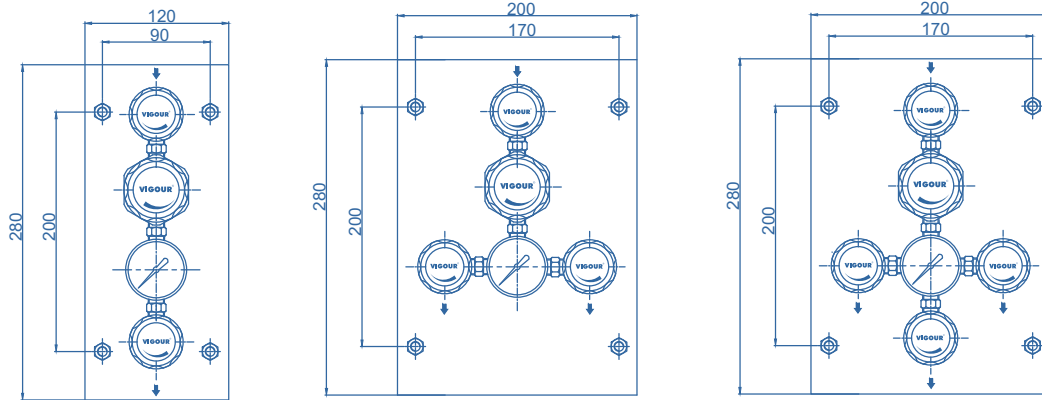

## Ordering Information:

**VSR - 1ETGS - 100 - 10 - A - N<sub>2</sub>**

### Body Material

S: 316L

C: Chrome Plated Brass

### Inlet Pressure P<sub>1</sub>

40: 40 bar

100: 100 bar

### Outlet Pressure P<sub>2</sub>

2: to 2 bar

4: to 4 bar

10: to 10 bar

20: to 20 bar

50: to 50 bar

### Gas Type

Please specify gas type

### Outlet Type

A: "A" type single outlet

B: "B" type dual outlet

C: "C" type triple outlet

# Tapping Points / Entnahmestellen

## VSR-2TG Series

### Product Features

- Wall-mounting tapping points
- VSR-2EL series single-stage regulator
- Stainless steel 316L body for corrosive gases
- Modular design
- Diaphragm type shut-off valves
- Suitable for inlet pressure up to 100 bar
- Tested for use with oxygen

### Typical Applications

- Component Testing
- Calibration Systems
- Laboratory Pressure Control
- High Pressure Sampling Systems
- Service & Test Equipment



### Technical Data

Type:	single-stage
Inlet pressure P <sub>1</sub> :	max. 100 bar
Outlet pressure P <sub>2</sub> :	2/4/10/20/35/50 bar
Materials:	
Body regulator and valves:	see ordering info
Valve seat (regulator):	PCTFE
(shut-off valve):	PEEK
Diaphragm(regulator):	Hastelloy® C276
(valve):	Hastelloy® C276
O-ring:	Viton® (FKM)
(option)	Kalrez® (FFKM)
Filter:	SS 316L
Temperature range:	-30°C to +74°C
Leak rate: (to atmosphere)	1x10 <sup>-8</sup> mbar l/s He
(via seat)	1x10 <sup>-6</sup> mbar l/s He
Flow capacity:	
(Outlet pressure:2/4/10/20 bar)	C <sub>v</sub> =0.28
(Outlet pressure:35/50 bar)	C <sub>v</sub> =0.08
Weight:	4.5 ~ 6.9 kg

### Schematic Drawing

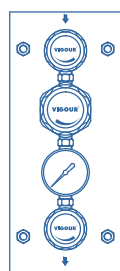

"A" Type:  
Single outlet

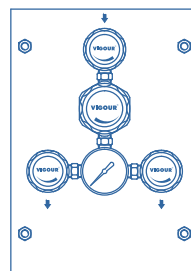

"B" Type:  
Dual outlet

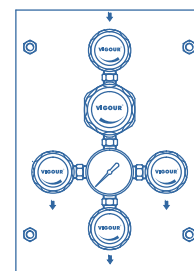

"C" Type:  
Triple outlet

### Flow Chart

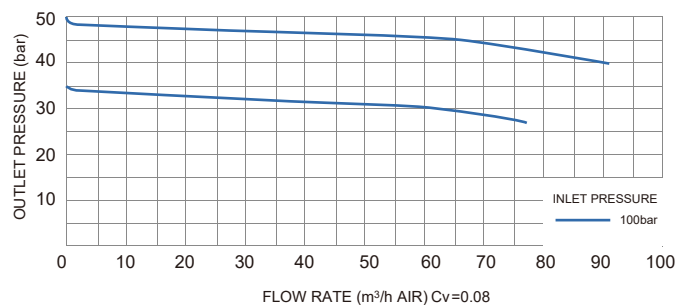
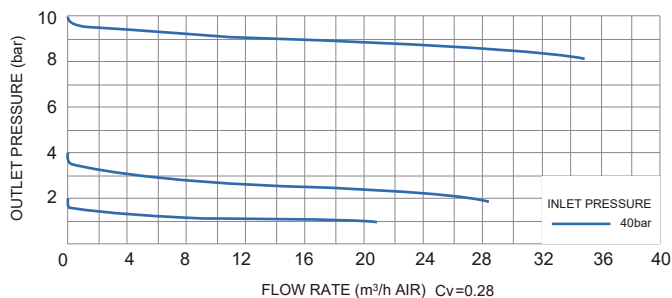

## Dimensions (mm)

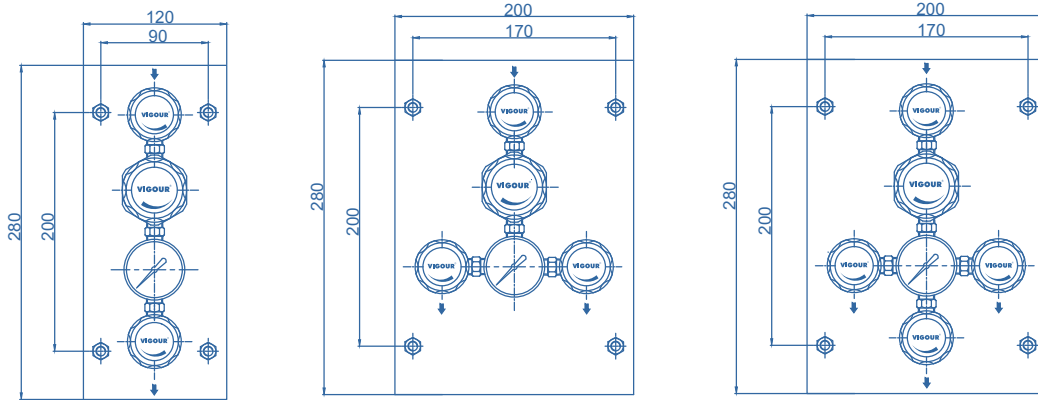

## Ordering Information:

**VSR - 2TGS - 100 - 10 - A - N2**

### Body Material

S: 316L  
C: Chrome Plated Brass

### Inlet Pressure P1

40: 40 bar  
100: 100 bar

### Outlet Pressure P2

2: to 2 bar  
4: to 4 bar  
10: to 10 bar  
20: to 20 bar  
35: to 35 bar  
50: to 50 bar

### Gas Type

Please specify gas type

### Outlet Type

A: "A" type single outlet  
B: "B" type dual outlet  
C: "C" type triple outlet

# Tapping Points / Entnahmestellen

## VSR-3T Series

### Product Features

- Bench-mounting tapping points
- Brass chromed plated body and bonnet for inert, reactive, flammable and oxidizing gas and mixtures up to grade 6.0
- Stainless steel 316L body and bonnet for corrosive gases
- VSR-1EL series single-stage regulator
- VDV2 series diaphragm valve
- Modular design
- Suitable for inlet pressure up to 60 bar
- Test for use with oxygen

### Typical Applications

- Component Testing
- Calibration Systems
- Laboratory Pressure Control
- High Pressure Sampling Systems
- Service & Test Equipment



Bench mounting  
hand wheel switch

Ceiling suspending  
Handle switch



Colours coding will be in accordance to CGA PS2 and UNI EN1089-3 standard

### Technical Data

Type:	single-stage
Inlet pressure P <sub>1</sub> :	max. 60 bar
Outlet pressure P <sub>2</sub> :	2/4/10/20 bar
Materials:	
Body regulator and valves:	see ordering info
Valve seat (regulator):	PCTFE
(shut-off valve):	PCTFE
Diaphragm(regulator):	Hastelloy® C276
(valve):	Hastelloy® C276
Filter:	SS 316L
Temperature range:	-30°C to +74°C
Leak rate (to atmosphere):	1x10 <sup>-8</sup> mbar l/s He
(via seat):	1x10 <sup>-6</sup> mbar l/s He
Flow capacity:	Cv=0.12
Weight:	1.6 kg

### Dimensions (mm)

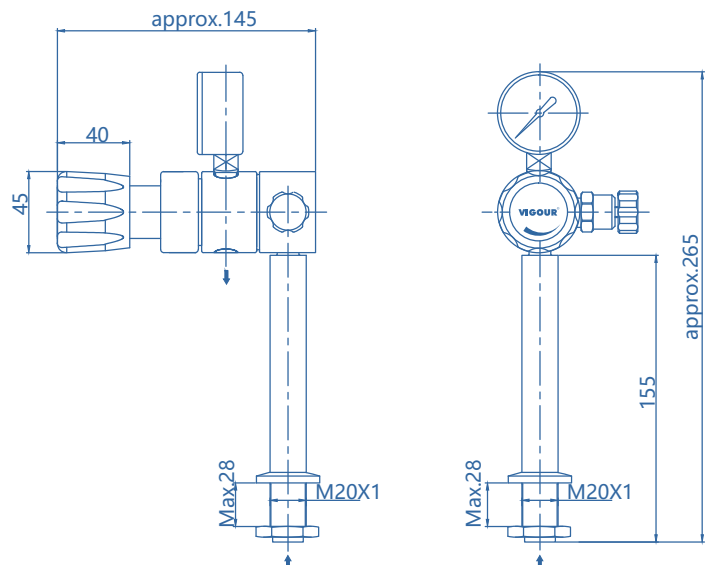

## Flow Chart

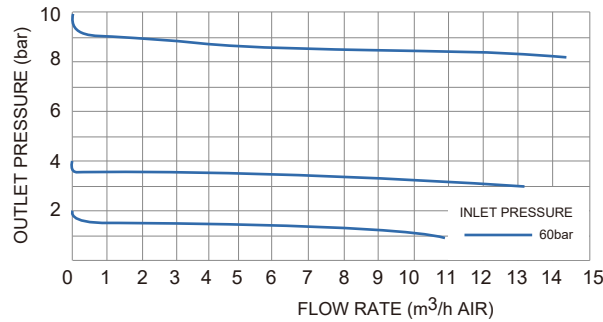

## Ordering Information:

**VSR - 3TS - 60 - 10 - 00 - 00 - W - N2 - X**

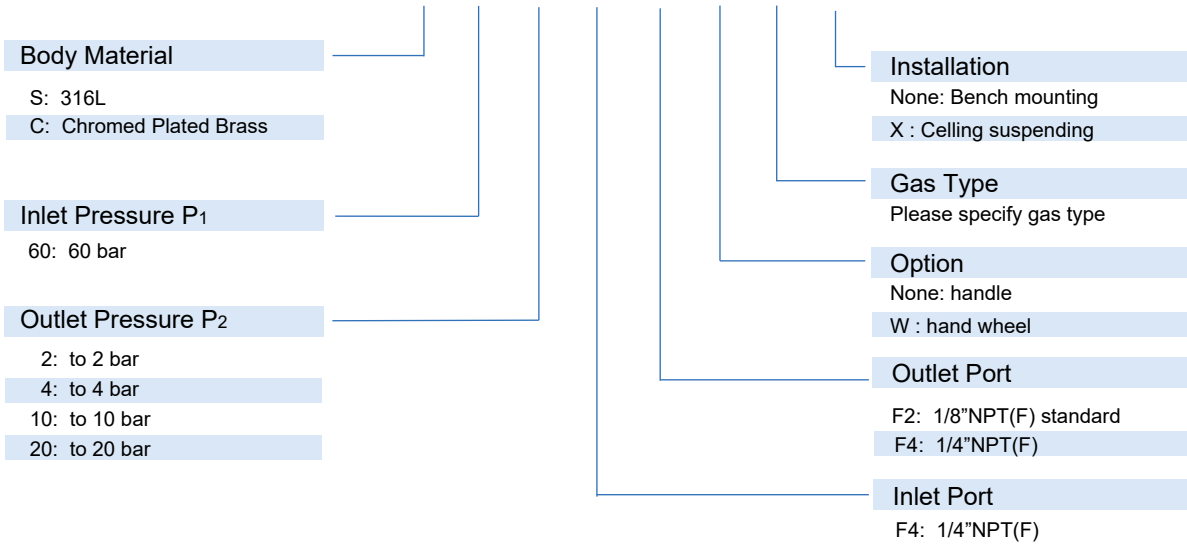



# Tapping Points / Entnahmestellen

## VSR-3TG Series

### Product Features

- Wall-mounting tapping points
- Brass chromed plated body and bonnet for inert, reactive, flammable and oxidizing gas and mixtures up to grade 6.0
- Stainless steel 316L body and bonnet for corrosive gases
- VSR-1EL series single-stage regulator
- VDV2 series diaphragm valve
- Modular design
- Suitable for inlet pressure up to 60 bar
- Test for use with oxygen



Handle switch

### Typical Applications

- Component Testing
- Calibration Systems
- Laboratory Pressure Control
- High Pressure Sampling Systems
- Service & Test Equipment



Colours coding will be in accordance to CGA PS2 and UNI EN1089-3 standard

### Technical Data

Type:	single-stage
Inlet pressure P <sub>1</sub> :	max. 60 bar
Outlet pressure P <sub>2</sub> :	2/4/10/20 bar
Materials:	
Body regulator and valves:	see ordering info
Valve seat (regulator):	PCTFE
(shut-off valve):	PCTFE
Diaphragm(regulator):	Hastelloy® C276
(valve):	Hastelloy® C276
Filter:	SS 316L
Temperature range:	-30°C to +74°C
Leak rate (to atmosphere):	1x10 <sup>-8</sup> mbar l/s He
(via seat):	1x10 <sup>-6</sup> mbar l/s He
Flow capacity:	Cv=0.12
Weight:	1.16 kg

### Dimensions (mm)

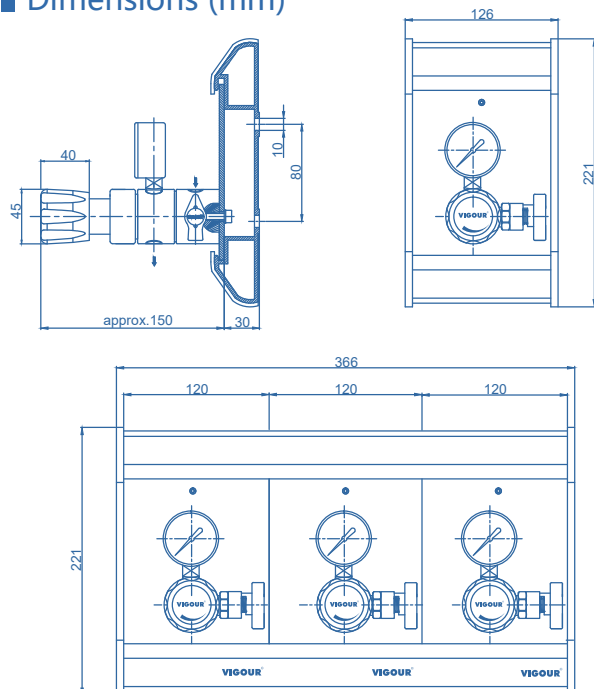

## Flow Chart

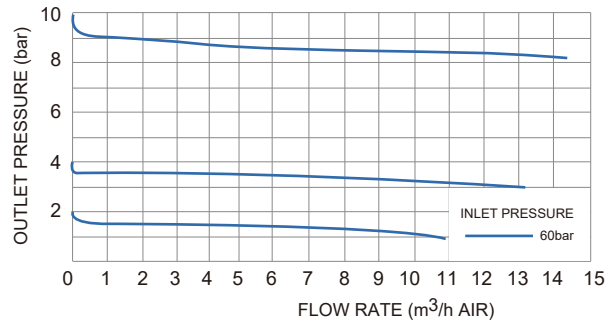

## Ordering Information:

**VSR - 3TGS - 60 - 10 - 00 - 00 - W - N2**

**Body Material**

S: 316L

C: Chromed Plated Brass

**Inlet Pressure P<sub>1</sub>**

60: 60 bar

**Outlet Pressure P<sub>2</sub>**

2: to 2 bar

4: to 4 bar

10: to 10 bar

20: to 20 bar

**Gas Type**

Please specify gas type

**Option**

None: hand wheel

W : Handle switch

**Outlet Port**

F2: 1/8"NPT(F) standard

F4: 1/4"NPT(F)

**Inlet Port**

F4: 1/4"NPT(F)

# Tapping Points / Entnahmestellen

## VSR-4T Series

### Product Features

- Panel-mounting tapping points
- Brass chromed plated body and bonnet for inert, reactive, flammable and oxidizing gas and mixtures up to grade 6.0
- Stainless steel 316L body and bonnet for corrosive gases
- VSR-1EL series single-stage regulator
- VDV2 series diaphragm valve
- Modular design
- Suitable for inlet pressure up to 60 bar
- Test for use with oxygen



Handle switch

### Typical Applications

- Component Testing
- Calibration Systems
- Laboratory Pressure Control
- High Pressure Sampling Systems
- Service & Test Equipment



Colours coding will be in accordance to CGA PS2 and UNI EN1089-3 standard

### Technical Data

Type:	single-stage
Inlet pressure P <sub>1</sub> :	max. 60 bar
Outlet pressure P <sub>2</sub> :	2/4/10/20 bar
Materials:	
Body regulator and valves:	see ordering info
Valve seat (regulator):	PCTFE
Diaphragm(regulator):	Hastelloy® C276
Filter:	SS 316L
Temperature range:	-30°C to +74°C
Leak rate (to atmosphere):	1x10 <sup>-8</sup> mbar l/s He
(via seat):	1x10 <sup>-6</sup> mbar l/s He
Flow capacity:	Cv=0.12
Weight:	0.8 kg

### Dimensions (mm)

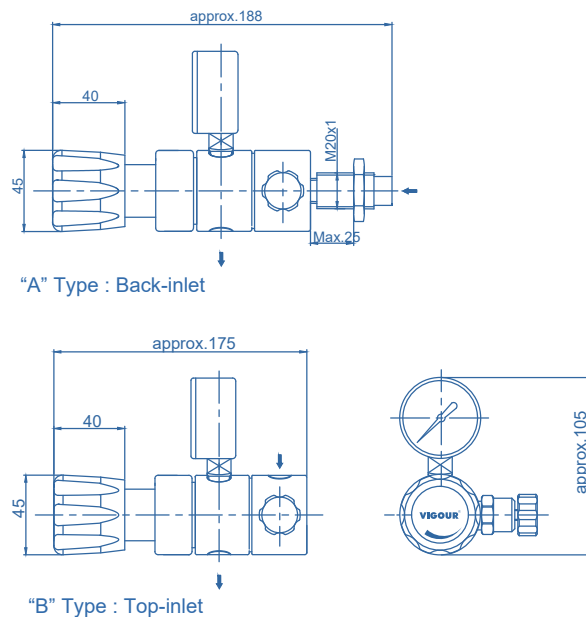

### Flow Chart

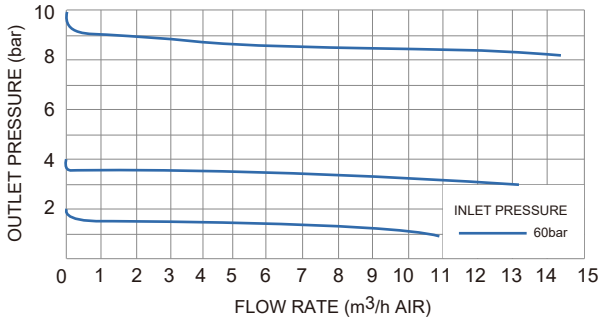

### Ordering Information:

**VSR - 4TS - 60 - 4 - 00 - 00 - A - W - N2**

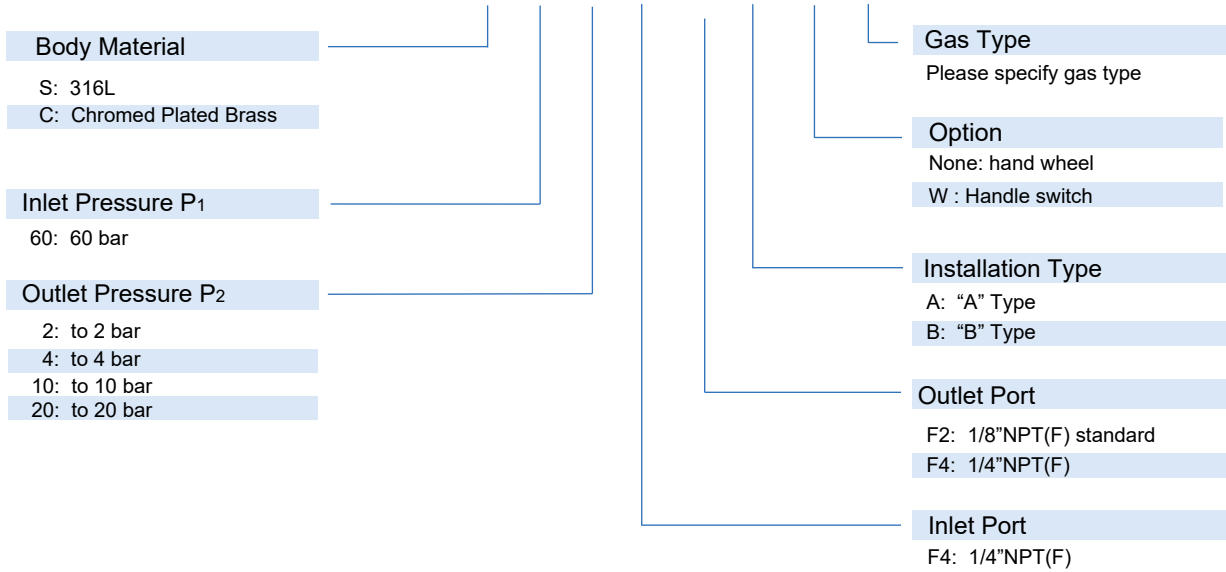

# Tapping Points / Entnahmestellen

## VSR-5T Series

### Product Features

- Wall-mounting tapping points
- VSR-1EL series single-stage regulator
- Aluminum for inert, reactive, flammable and oxidizing gas and mixtures up to grade 6.0
- Modular design
- Diaphragm type shut-off valve
- Suitable for inlet pressure up to 60 bar
- Tested for use with oxygen
- Compact design tapping point

### Typical Applications

- Component Testing
- Calibration Systems
- Laboratory Pressure Control
- Service & Test Equipment



### Technical Data

Type:	single-stage
Inlet pressure P <sub>1</sub> :	max. 60 bar
Outlet pressure P <sub>2</sub> :	2/4/10 bar
<b>Materials:</b>	
Body regulator and valves:	see ordering info
Valve seat (regulator):	PCTFE
(shut-off valve):	PEEK
Diaphragm (regulator):	Hastelloy® C276
(valve):	Hastelloy® C276
Filter:	SS 316L
Temperature range:	-30°C to +74°C
Leak rate (to atmosphere):	1x10 <sup>-8</sup> mbar l/s He
(via seat):	1x10 <sup>-6</sup> mbar l/s He
Flow capacity:	Cv=0.07
Weight:	2.5 kg

### Schematic Drawing



### Flow Chart

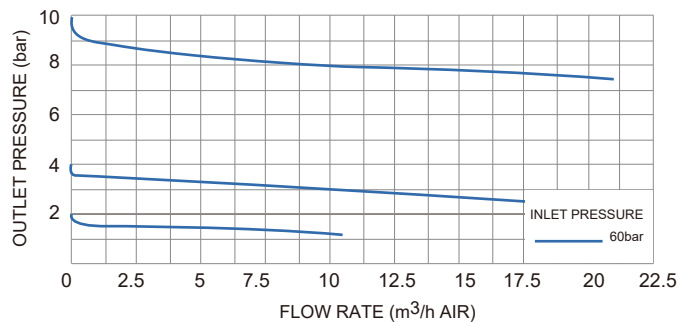

## Dimensions (mm)

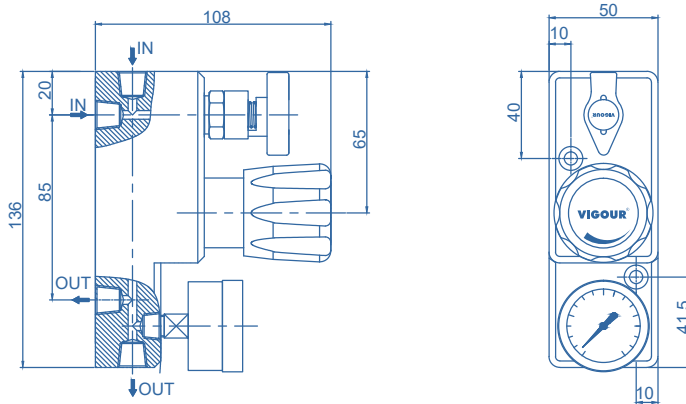

## Ordering Information:

**VSR - 5TA - 60 - 10 - N<sub>2</sub>**

**Body Material**

A: Aluminum

**Inlet Pressure P<sub>1</sub>**

60: 60 bar

**Gas Type**

Please specify gas type

**Outlet Pressure P<sub>2</sub>**

2: to 2 bar

4: to 4 bar

10: to 10 bar

20: to 20 bar

# Extensions / Erweiterungspaneile

## VSP-X Series

### Product Features

- Brass chrome plated body for inert, reactive, - flammable and oxidizing gas and mixtures up to grade 6.0
- Stainless steel 316L body for corrosive gases
- Extension for pressure control panel
- Design for easy installation



### Typical Applications

- Component Testing
- Calibration Systems
- Laboratory Pressure Control
- High Pressure Sampling Systems
- Service & Test Equipment

### Technical Data

Inlet pressure P <sub>1</sub> :	max. 300 bar
Materials:	see ordering info
O-ring: (option)	Viton® (FKM) Kalrez® (FFKM)
Temperature range:	-30°C to +74°C
Weight:	1.2 kg

### Dimensions (mm)

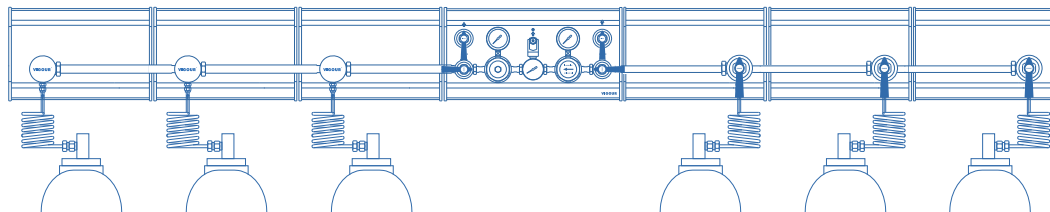
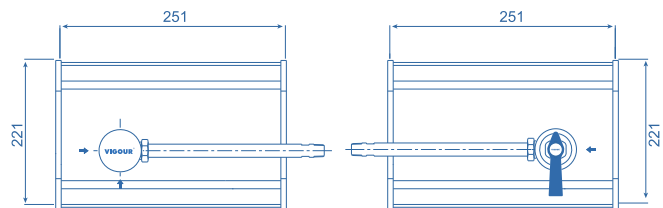

### Ordering Information:

**VSP - X - S - 1R - 1L - DV - O<sub>2</sub>**

#### Body Material

- S: 316L
- C: Chrome plated brass

#### Right Extension

- 1: Single extension
- 2: Dual extensions
- 3: Triple extensions
- n: "2,3,4..." extensions

#### Gas Type

Please specify gas type

#### Valve

- None: Block W/O valve
- DV: VDV30 Diaphragm valve

#### Left Extension

- 1: Single extension
- 2: Dual extensions
- 3: Triple extensions
- n: "2,3,4..." extensions

# Flaschenanschlusspanel / Mounting Station VSP-S Series

## Product Features

- Single regulator mounting station
- For one or two cylinders
- Standard c/w 1 set of 36" pigtail and integral check valve
- Design for easy installation
- Tested for use with oxygen

## Typical Applications

- Component Testing
- Calibration Systems
- Laboratory Pressure Control
- High Pressure Sampling Systems
- Service & Test Equipment



## Technical Data

Inlet pressure P1:	max. 300 bar
Materials:	see ordering info
Temperature range:	-30°C to +74°C
Weight:	1.2 kg

## Dimensions (mm)

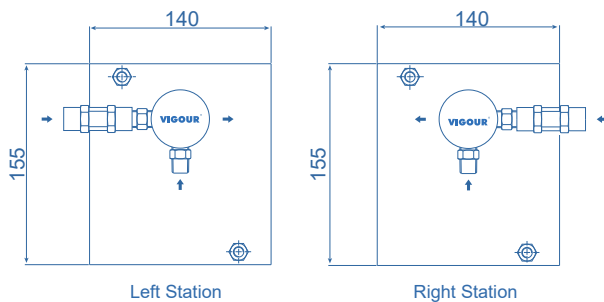

## Schematic Drawing

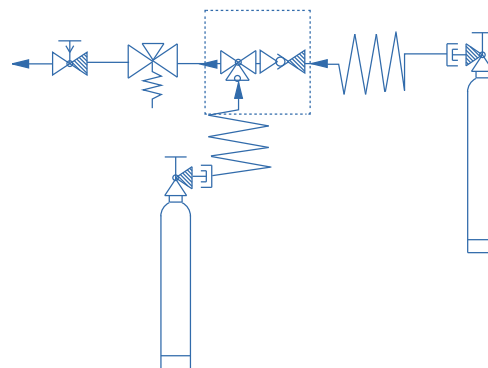

## Ordering Information:

**VSP - S - S - F - CGA - L - 2 - N2 - VSR1**

### Body Material

- S: 316L
- C: Chrome plated brass

### Pigtail Material

- F: Core TEFLON PTFE
- S: Core 316SST

### Cylinder Connections

- DIN: Germany
- CGA: USA
- BSP: British
- GB: China
- UNI: Italy
- NF: French
- JIS: Japan

### Regulator

- F4: 1/4"NPT(F) w/o regulator
- VSR1E: VSR1E series regulator
- VSR2: VSR2 series regulator
- VSR3: VSR3 series regulator
- VSR6: VSR6 series regulator

### Type of Gas

Please specify type of gas

### Cylinder

- 1: Use for one cylinder
- 2: Use for two cylinders

### Station

- L: Left Station
- R: Right Station



# Purge Assemblies / Spüleinheiten

## VSP-U Series

### Product Features

- Purge assemblies
  - Brass chrome plated body for inert, reactive, flammable and oxidizing gas and mixtures up to grade 6.0
  - Stainless steel 316L for corrosive gases
  - Diaphragm type shut-off valves
  - Suitable for inlet pressure up to 300 bar
  - Tested for use with oxygen
- **Straight purge assemblies**  
The straight purge assembly is connected to the regulator body via an auxiliary high pressure port. The gas is vented through the body to a downstream location.
  - **Tee purge assemblies**  
The tee purge can be connected between the cylinder and the regulator, or between the regulator and the instrument. The system can be flushed with the purging gas to remove contaminants prior to start-up or after a cylinder change.
  - **Cross purge assemblies**  
The cross purge assembly is used between the cylinder and the regulator. In addition to the features on the tee purge, the cross purge assembly allows the use of inert purge gas.
  - **Block & bleed purge assemblies**  
Block and bleed purges are typically used in manifolds or other applications where atmospheric contaminants need to be purged after cylinder changeout.



Straight purge assemblies



Tee purge assemblies



Cross purge assemblies



Block & bleed purge assemblies

### Technical Data

Type:	Purge assemblies
Inlet pressure:	Max.300 bar
Materials	
Body:	see ordering info
Diaphragm:	Hastelloy® C276 Elgiloy®
Seat:	PEEK
Filter:	SS316L
Inlet connection:	1/4"NPT(F)
Temperature range:	-30°C to +74°C
Leak rate:	10 <sup>-8</sup> mbar l/s He
Orifice:	Φ2.7 mm

# Spüleinheiten / Purge Assemblies VSP-U Series

## Schematic Drawing

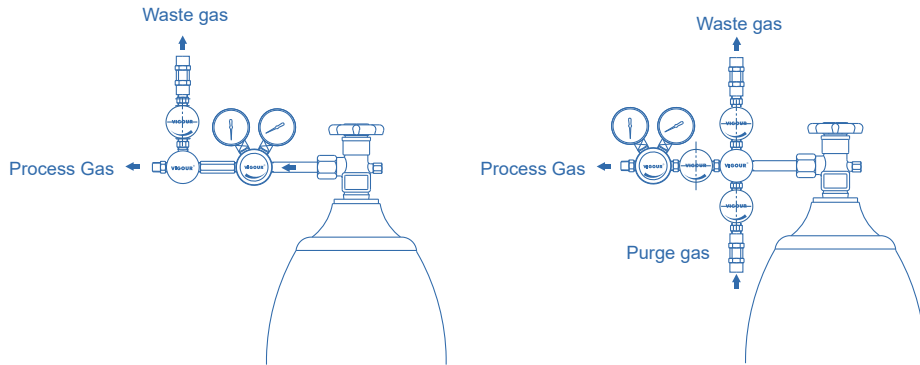

## Ordering Information:

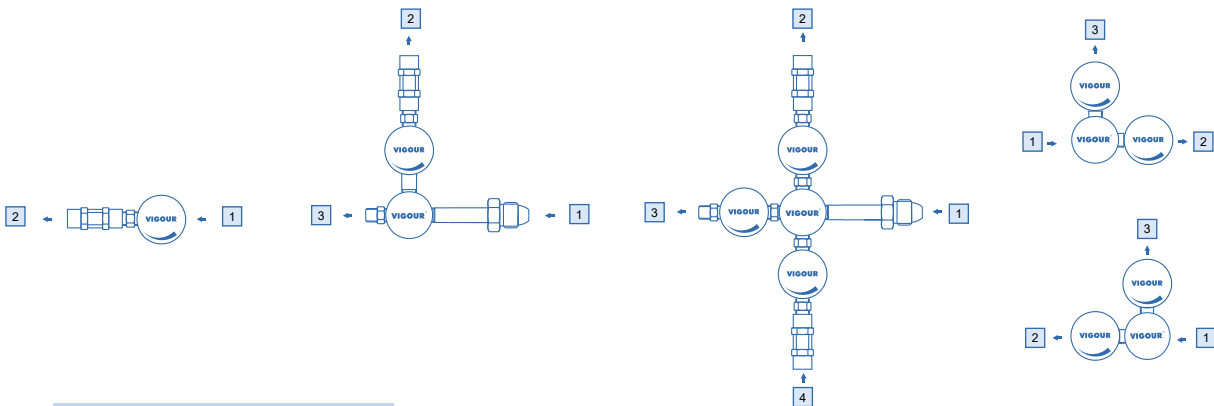

### Inlets / Outlets

F4: 1/4" NPT(F)	04: 1/4" Tube fitting	CGA: USA	GB: China
M4: 1/4" NPT(M)	DIN: Germany	UNI: Italy	CV: Check valve
02: 1/8" Tube fitting	BSP: British	NF: French	

\* Other connection standard, consult factory.

### Port Selection

VSP - U S C - 1 - 2 - 3 - 4 - N2

### Type

- S: Straight purge assemblies
- T: Tee purge assemblies
- C: Cross purge assemblies
- LB: Left block & bleed purge assemblies
- RB: Right block & bleed purge assemblies

### Type of Gas

Please specify type of gas

### Body Material

- S: 316L
- C: Chrome plated brass

# Diaphragm Valves / Membranventile

## VDV1 Series

### Product Features

- Diaphragm valve
- Brass chrome plated body and bonnet for inert, reactive, flammable and oxidizing gas and mixtures up to grade 6.0
- Stainless steel 316L body for corrosive gases
- Suitable for inlet pressure up to 60 bar, hand wheel design
- Wide range of inlets / outlets
- Metal-to-metal sealing to atmosphere
- Tested to use with oxygen

### Typical Applications

- Component Testing
- Calibration Systems
- Laboratory Pressure Control
- High Pressure Sampling Systems
- Service & Test Equipment



### Technical Data

Type: Diaphragm valve

Inlet pressure: Max. 60 bar

Materials

Body: see ordering info

Seat: PEEK

Diaphragm: Elgiloy®

Filter: SS316L

Inlet / outlet connection: 1/4"NPT(F)

Temperature range: -30°C to +74°C

Leak rate: 10<sup>-8</sup> mbar l/s He

Orifice: Φ4 mm

Weight: 0.5 kg

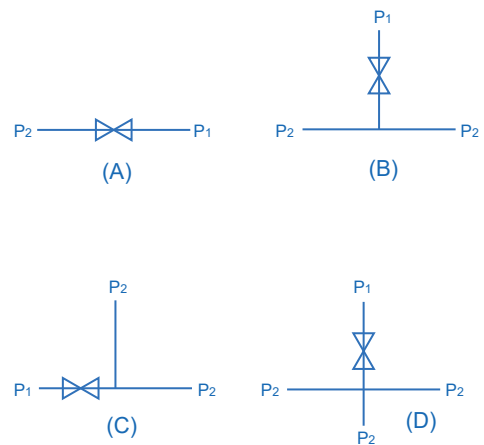

### Dimensions (mm)

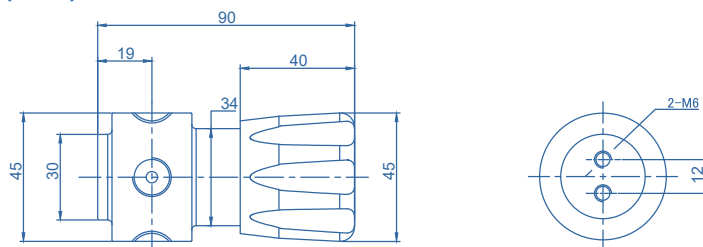

### Ordering Information

**VDV 1 - C - A - F4 - F4**

Body Material

S: 316L

C: Chrome plated brass

Type

A: 2 ports

B: 3 ports

C: 3 ports

D: 4 ports

Inlets / Outlets

F4: 1/4"NPT(F)

F6: 3/8"NPT(F)

# Membranventile / Diaphragm Valves

## VDV2 Series

### Product Features

- Diaphragm valve
- Brass chrome plated body for inert, reactive, flammable and oxidizing gas and mixtures up to grade 6.0
- Stainless steel 316L body for corrosive gases
- Suitable for inlet pressure up to 60 bar
- Metal-to-metal sealing to atmosphere
- Tested to use with oxygen

### Typical Applications

- Component Testing
- Calibration Systems
- Laboratory Pressure Control
- High Pressure Sampling Systems
- Service & Test Equipment

### Technical Data

Type:	Diaphragm valve
Inlet pressure	Max.60 bar
Materials	
Body:	see ordering info
Seat:	PEEK
Diaphragm:	Hastelloy® C276
Inlet / outlet connection:	1/4"NPT(M) / 1/4"NPT(F)
Temperature range:	-30°C to +74°C
Leak rate:	10 <sup>-8</sup> mbar l/s He
Orifice:	Φ3.2 mm
Weight:	0.3 kg



### Dimensions (mm)

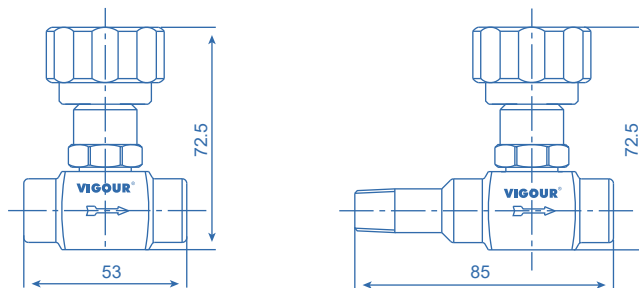

### Ordering Information

**VDV2 - C - M4- F4**

Body Material

S: 316L  
C: Chrome plated brass

Inlets / Outlets

F4: 1/4"NPT(F)  
M4: 1/4"NPT(M)

# High Pressure Diaphragm Valve / Hochdruck Membranventile VDV30 Series

## Product Features

- Diaphragm valve
- Brass chrome plated body and bonnet for inert, reactive, flammable and oxidizing gas and mixtures up to grade 6.0
- Stainless steel 316L body for corrosive gases
- Inlet pressure max 300 bar
- Left or Right lever direction for Shutoff
- Wide range of inlets / outlets
- Metal-to-metal sealing to atmosphere
- Tested to use with oxygen

## Typical Applications

- Component Testing
- Calibration Systems
- Laboratory Pressure Control
- High Pressure Sampling Systems
- Service & Test Equipment

## Technical Data

Type:	Diaphragm valve
Inlet pressure	Max.300 or 200 bar
Materials	
Body	see ordering info
Seat:	PCTFE
Diaphragm:	Elgiloy®
Filer:	SS316L
Inlet / outlet connection:	1/4"NPT(M)
Temperature range:	-30°C to +74°C
Leak rate:	10 <sup>-8</sup> mbar l/s He
Orifice:	Φ2.7 mm
Weight:	0.5 kg

## Dimensions (mm)

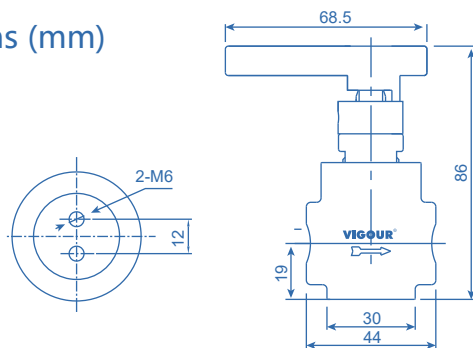

optional hand wheel

## Schematic Drawing

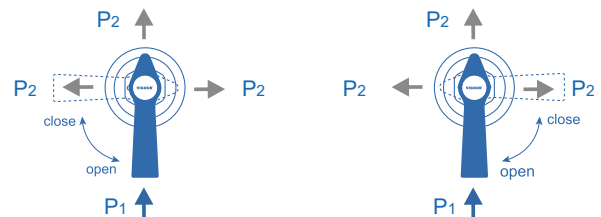

Right lever for Shutoff

Left lever for Shutoff

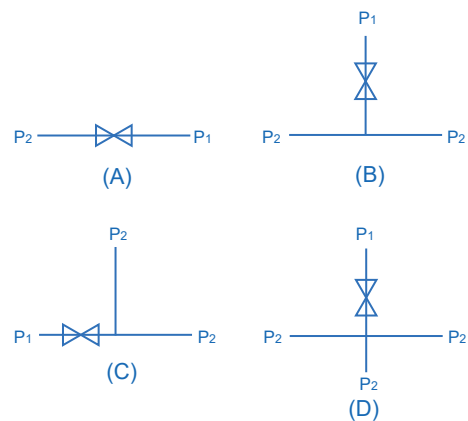

## Ordering Information

VDV 30- C - A - F4 - F4 - L

### Body Material

- S: 316L
- C: Chrome plated brass

### Type

- A: 2 ports
- B: 3 ports
- C: 3 ports
- D: 4 ports

### Lever

- None: Right lever for Shutoff
- L : Left lever for Shutoff
- W : Hand Wheel Shutoff

### Inlets / Outlets

- F4: 1/4"NPT(F)
- F6: 3/8"NPT(F)

# Hochdruck Membranventile / High Pressure Diaphragm Valve VDV31 Series

## Product Features

- Diaphragm valve
- Stainless steel 316L body for corrosive gases
- Inlet pressure max 300 bar
- Left or Right lever direction for Shutoff
- Wide range of inlets / outlets
- Metal-to-metal sealing to atmosphere

## Typical Applications

- Component Testing
- Calibration Systems
- Laboratory Pressure Control
- High Pressure Sampling Systems
- Service & Test Equipment

## Technical Data

Type:	Diaphragm valve
Inlet pressure	Max.300 bar
Materials	
Body:	see ordering info
Seat:	PCTFE
Diaphragm:	Elgiloy®
Filer:	SS316L
Inlet / outlet connection:	1/4"NPT(M)
Temperature range:	-30°C to +74°C
Leak rate:	10 <sup>-8</sup> mbar l/s He
Orifice:	Φ2.7 mm
Weight:	0.2 kg

## Dimensions (mm)

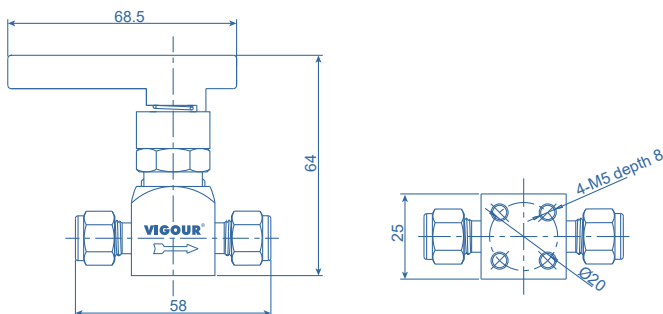

## Ordering Information

**VDV 31 - S - 04 - 04 - L**

### Material

S: 316L

### Inlets / Outlets

M4: 1/4" NPT(M)

02: 1/8" Tube Fitting

04: 1/4" Tube Fitting

6M: 6mm Tube Fitting

8M: 8mm Tube Fitting

### Lever

None: Right lever for Shutoff

L : Left lever for Shutoff



## Schematic Drawing



Right lever for Shutoff

Left lever for Shutoff

# Diaphragm Valves / Membranventile

## VDV8 Series

### Product Features

- Diaphragm valve
- Brass chrome plated body for inert, reactive, flammable and oxidizing gas and mixtures up to grade 6.0
- Stainless steel 316L body for corrosive gases
- Suitable for pressures up to 40 bar
- Wide range of inlets / outlets
- Metal-to-metal sealing to atmosphere
- Tested to use with oxygen

### Typical Applications

- Component Testing
- Calibration Systems
- Laboratory Pressure Control
- High Pressure Sampling Systems
- Service & Test Equipment



### Technical Data

Type: Diaphragm valve

Inlet pressure: Max. 40 bar

Materials:

Body: see ordering info

Seat: PCTFE

Diaphragm: Hastelloy® C276

Filer: SS316L

Inlet / outlet connection: 3/8" NPT(M)

Temperature range: -30°C to +74°C

Leak rate: 10<sup>-8</sup> mbar l/s He

Orifice: Ø8 mm

Weight: 0.8 kg

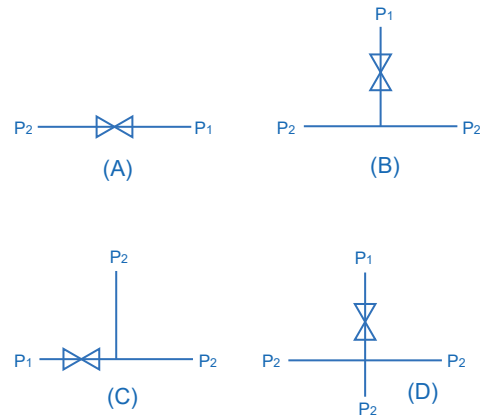

### Dimensions (mm)

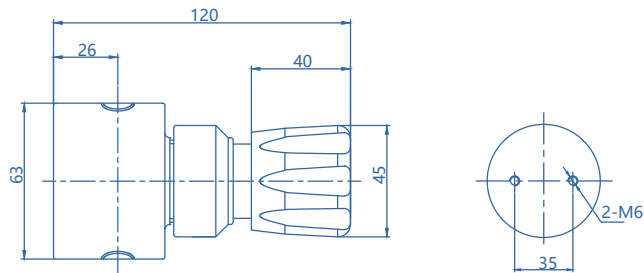

### Ordering Information

**VDV8 - C - A - F6 - F6**

Body Material

S: 316L

C: Chrome plated brass

Type

A: 2 ports

B: 3 ports

C: 3 ports

D: 4 ports

Inlets / Outlets

F6: 3/8" NPT(F)

F8: 1/2" NPT(F)

# Kugelhähne / Ball Valves VBV1 Series

## Product Features

- Bi-directional flow (fully opened or fully closed)
- Directional handle indicating on-off position
- Allow for panel mounting
- Single piece ball stem to eliminate backlash
- One piece body to eliminate multiple seal points.
- Unique, top-loaded capsule packing allows reliable switching
- Tested for use with oxygen



## Typical Applications

- Calibration Systems
- Laboratory Pressure Control
- High Pressure Sampling Systems
- Service & Test Equipment

## Technical Data

Type:	Ball valve
Pressure Rating:	206 bar
Materials	
Body:	316
Seat:	PTFE
Temperature range:	-54°C to 148°C
Leak rate:	0.1 std cc/min @1000psig(69bar) with N <sub>2</sub>
Orifice:	Φ2.4~10.3 mm (according to end connections)

## Dimensions

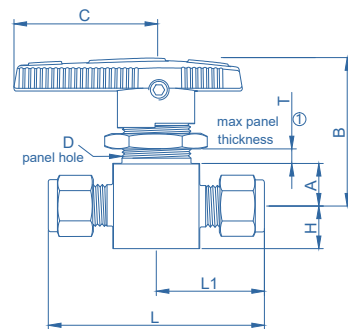

① 1/8 in.(3.2mm) minimum panel thickness.  
Straight Pattern

## Pressure vs. Temperature

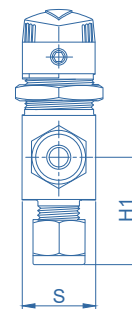
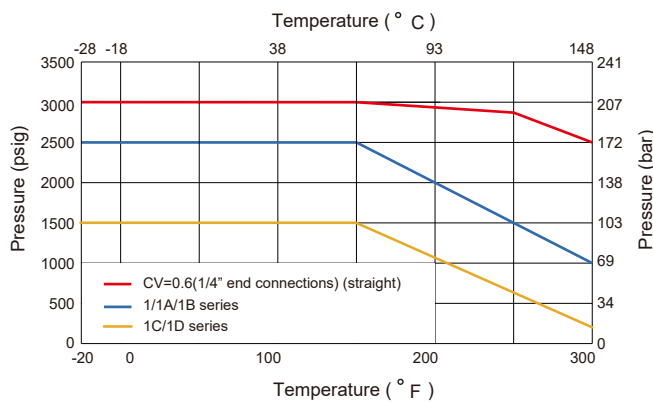

Angle Pattern



# Ball Valves / Kugelhähne

## VBV1 Series

### Dimensions

End Connections		Cv		Ordering Number	Orifice in.	Dimensions, in. (mm)									
Inlet/Outl	Size	Cv	Angl			L	L1	H1	A	H	C	T	D	B	S
Fractional tube fittings	1/16 in.	0.10	—	SS-VBV1-01-01	0.052 (1.32)	1.68 (42.7)	0.84 (21.3)	—	0.34 (8.6)	0.28 (7.1)	1.12 (28.4)	1/4 (6.4)	19/32 (15.1)	1.36 (34.5)	0.58 (14.7)
	1/8 in.	0.20	0.15	SS-VBV1-02-02	0.093 (2.36)	2.01 (51.1)	1.01 (25.7)	0.97 (24.6)							
	1/4 in.	0.60	0.35	SS-VBV1A-04-04	0.125 (3.18)	2.21 (56.1)	1.10 (27.9)	1.07 (27.2)							
		2.4	0.90	SS-VBV1B-04-04	0.187 (4.75)	2.36 (59.9)	1.18 (30)	1.17 (29.7)							
	3/8 in.	1.5	0.90	SS-VBV1B-06-06	0.187 (4.75)	2.58 (65.5)	1.29 (32.8)		0.44 (11.2)	0.38 (9.7)	1.53 (38.9)	3/16 (4.8)	25/32 (19.8)	1.56 (39.6)	0.78 (19.8)
		6.0	2.0	SS-VBV1C-06-06	0.281 (7.14)	3.05 (77.5)	1.52 (38.6)	1.43 (36.3)							
	1/2 in.	6.3	4.6	SS-VBV1D-08-08	0.406 (99.6)	3.92 (99.6)	1.96 (49.8)	1.74 (44.2)	0.56 (14.2)		2.00 (50.8)	3/8 (9.5)	1 1/8 (28.6)	2.07 (52.6)	1.12 (28.4)
3/4 in.	6.4	3.8	SS-VBV1D-12-12	0.406 (10.3)	3.92 (99.6)	1.96 (49.8)	1.74 (44.2)	0.69 (17.5)		3.00 (76.2)	1 1/2 (38.1)		2.43 (61.7)	1.5 (38.1)	
Metric tube fittings	3 mm	0.20	0.15	SS-VBV1-3M-3M	0.093 (2.36)	2.01 (51.1)	1.01 (25.7)	0.97 (24.6)	0.34 (8.6)	0.28 (7.1)	1.12 (28.4)	1/4 (6.4)	19/32 (15.1)	1.36 (34.5)	0.58 (14.7)
	6 mm	0.60	0.35	SS-VBV1A-6M-6M	0.125 (3.18)	2.21 (56.1)	1.10 (27.9)	1.07 (27.2)							
		2.4	0.90	SS-VBV1B-6M-6M	0.187 (4.75)	2.39 (60.7)	1.20 (30.5)	1.17 (29.7)	0.44 (11.2)	0.38 (9.7)	1.53 (38.9)	3/16 (4.8)	25/32 (19.8)	1.56 (39.6)	0.78 (19.8)
	8 mm	1.5	0.90	SS-VBV1B-8M-8M	0.187 (4.75)	2.46 (62.5)	1.23 (31.2)	1.2 (30.5)							
	10 mm	6.0	2.0	SS-VBV1C-10M-10M	0.281 (7.14)	3.07 (78.0)	1.53 (38.9)	1.43 (36.9)	0.56 (14.2)		2.00 (50.8)	3/8 (9.5)	1 1/8 (28.6)	2.07 (52.6)	1.12 (28.4)
	12 mm	12	4.6	SS-VBV1D-12M-12M	0.406 (10.3)	3.92 (99.6)	1.96 (49.8)	1.74 (44.2)	0.69 (17.5)		3.00 (76.2)		1 1/2 (38.1)	2.43 (61.7)	1.5 (38.1)
Female NPT	1/8 in.	0.50	0.30	SS-VBV1A-F2-F2	0.125 (3.18)	1.62 (41.1)	0.81 (20.6)		0.34 (8.6)	0.28 (7.1)	1.12 (28.4)	1/4 (6.4)	19/32 (15.1)	1.36 (34.5)	0.58 (14.7)
		1.2	0.70	SS-VBV1B-F2-F2	0.187 (4.75)	2.00 (50.8)	1.00 (25.4)								
	1/4 in.	0.90	0.75	SS-VBV1B-F4-F4	0.187 (4.75)	2.06 (52.3)	1.03 (26.2)		0.44 (11.2)	0.38 (9.7)	1.53 (38.9)	3/16 (4.8)	25/32 (19.8)	1.56 (39.6)	0.78 (19.8)
		3.0	1.7	SS-VBV1C-F4-F4	0.281 (7.14)	2.50 (63.5)	1.25 (31.8)								
	3/8 in.	2.6	1.5	SS-VBV1D-F6-F6	0.406 (10.3)	3.12 (79.2)	1.56 (39.6)		0.56 (14.2)		2.00 (50.8)	3/8 (9.5)	1 1/8 (28.6)	2.07 (52.6)	1.12 (28.4)
	1/2 in.	6.3	3.5	SS-VBV1D-F8-F8	0.406 (10.3)	3.12 (79.2)	1.56 (39.6)		0.69 (17.5)		3.00 (76.2)		1 1/2 (38.1)	2.43 (61.7)	1.50 (38.1)

Dimensions shown with tube fitting nuts finger-tight.

### Ordering Information

#### SS - VBV1 - 04-04 - A

##### Materials

SS: 316

##### Series

VBV1: see above table  
 VBV1A: see above table  
 VBV1B: see above table  
 VBV1C: see above table  
 VBV1D: see above table

##### Options

A: Angle Pattern  
 None: Straight Pattern

##### End Connections

Fractional tube fittings: see above table  
 Metric tube fittings: see above table  
 Female NPT: see above table

### Product Features

- Bi-directional flow (fully opened or fully closed)
- Directional handle indicating on-off position
- Allow for panel mounting
- Single piece ball stem to eliminate backlash
- Unique, top-loaded capsule packing allows reliable switching
- Tested for use with oxygen



### Typical Applications

- Calibration Systems
- Laboratory Pressure Control
- High Pressure Sampling Systems
- Service & Test Equipment

### Technical Data

Type:	Ball valve
Pressure Rating:	206 bar
Materials	
Body:	316
Seat:	PTFE
Temperature range:	-54°C to 148°C
Leak rate:	0.1 std cc/min @1000psig(69bar) with N <sub>2</sub>
Orifice:	Φ2.4~10.3 mm (according to end connections)

### Pressure vs. Temperature

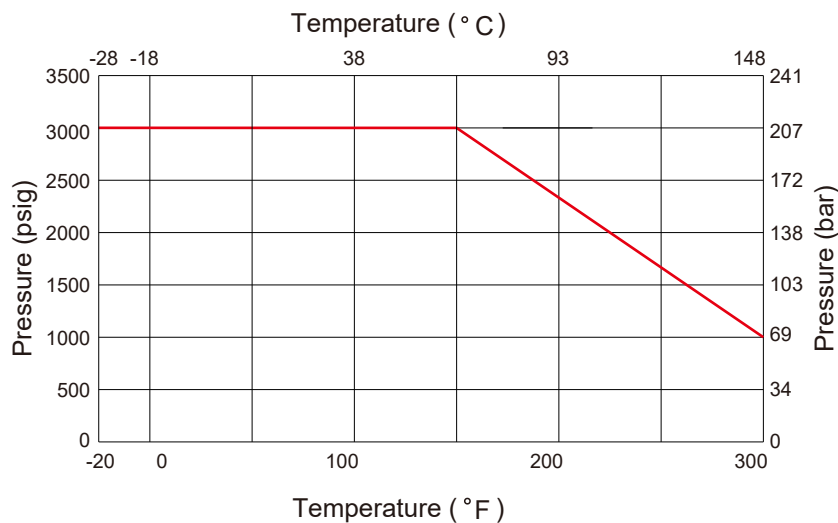

# Ball Valves / Kugelhähne

## VBV2 Series

### Dimensions

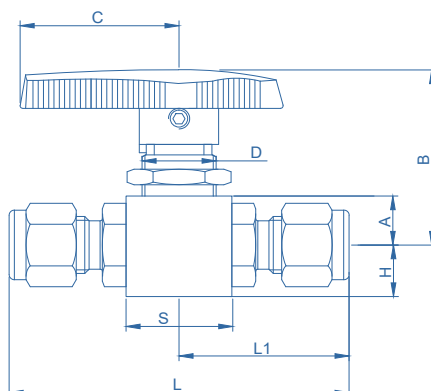

End Connections	End Connection Size	Ordering Number	Orifice in. (mm)	Dimensions, in. (mm)							
				L	L1	H	A	B	C	D	S
Fractional tube fittings	1/8 in.	SS-VBV2-02-02	0.087 (2.2)	2.39 (60.8)	1.20 (30.4)	0.39 (10)	0.37 (9.5)	1.32 (33.6)	1.15 (29.3)	0.55 (14)	0.79x0.79 (20X20)
	1/4 in.	SS-VBV2-04-04	0.189 (4.8)	2.53 (64.3)	1.27 (32.15)	0.39 (10)	0.37 (9.5)	1.32 (33.6)	1.15 (29.3)	0.55 (14)	0.79x0.79 (20X20)
	3/8 in.	SS-VBV2-06-06	0.197 (5.0)	2.74 (69.6)	1.37 (34.8)	0.39 (10)	0.37 (9.5)	1.32 (33.6)	1.15 (29.3)	0.55 (14)	0.79x0.79 (20X20)
	1/2 in.	SS-VBV2-08-08	0.354 (9.0)	3.25 (82.5)	1.62 (41.25)	0.49 (12.5)	0.49 (12.5)	1.68 (42.7)	1.56 (39.6)	0.75 (19)	0.98x0.98 (25X25)
Metric tube fittings	3mm	SS-VBV2-3M-3M	0.087 (2.2)	2.43 (61.8)	1.22 (30.9)	0.39 (10)	0.37 (9.5)	1.32 (33.6)	1.15 (29.3)	0.55 (14)	0.79x0.79 (20X20)
	6mm	SS-VBV2-6M-6M	0.189 (4.8)	2.57 (65.3)	1.29 (32.65)	0.39 (10)	0.37 (9.5)	1.32 (33.6)	1.15 (29.3)	0.55 (14)	0.79x0.79 (20X20)
	8mm	SS-VBV2-8M-8M	0.197 (5.0)	2.65 (67.3)	1.34 (33.65)	0.39 (10)	0.37 (9.5)	1.32 (33.6)	1.15 (29.3)	0.55 (14)	0.79x0.79 (20X20)
	10mm	SS-VBV2-10M-10M	0.197 (5.0)	2.82 (71.6)	1.41 (35.8)	0.39 (10)	0.37 (9.5)	1.32 (33.6)	1.15 (29.3)	0.55 (14)	0.79x0.79 (20X20)
	12mm	SS-VBV2-12M-12M	0.354 (9.0)	3.29 (83.5)	1.64 (41.75)	0.49 (12.5)	0.49 (12.5)	1.68 (42.7)	1.56 (39.6)	0.75 (19)	0.98x0.98 (25X25)

### Ordering Information

**SS - VBV2 - 04-04**

Material

SS: 316

End Connections

Fractional tube fittings: see above table

Metric tube fittings: see above table

## Product Features

- Bi-directional flow (fully opened or fully closed)
- Directional handle indicating on-off position
- Low operating torque
- Encapsulated seat
- Single piece ball stem to eliminate backlash
- One piece body to eliminate multiple seal points.
- Unique, top-loaded capsule packing allows reliable switching
- Tested to use with oxygen



yellow handle

## Typical Applications

- Component Testing
- Calibration Systems
- Laboratory Pressure Control
- High Pressure Sampling Systems
- Service & Test Equipment



short handle



butterfly handle

## Technical Data

Type:	yellow handle / short handle / butterfly handle
Pressure rating:	1000psig @ 38°C
Materials	
Body:	316
Seat:	Teflon® (PTFE)
Orifice:	
6mm/1/4" tube fitting, 1/4NPT	φ5mm
10mm/3/8" tube fitting	φ7 mm
12mm/1/2" tube fitting, 1/2NPT	φ9 mm
Weight:	
6mm/1/4" tube fitting, 1/4NPT	0.13 kg (yellow handle and butterfly handle), 0.1 kg (short handle)
10mm/3/8" tube fitting	0.22 kg (yellow handle and butterfly handle), 0.16 kg (short handle)
12mm/1/2" tube fitting, 1/2NPT	0.35 kg (yellow handle and butterfly handle), 0.26 kg (short handle)
Temperature range:	-42°C to +204°C
Leak rate:	0.1 std cc/min

# Ball Valve / Kugelhahn VBV3 Series

## Dimensions

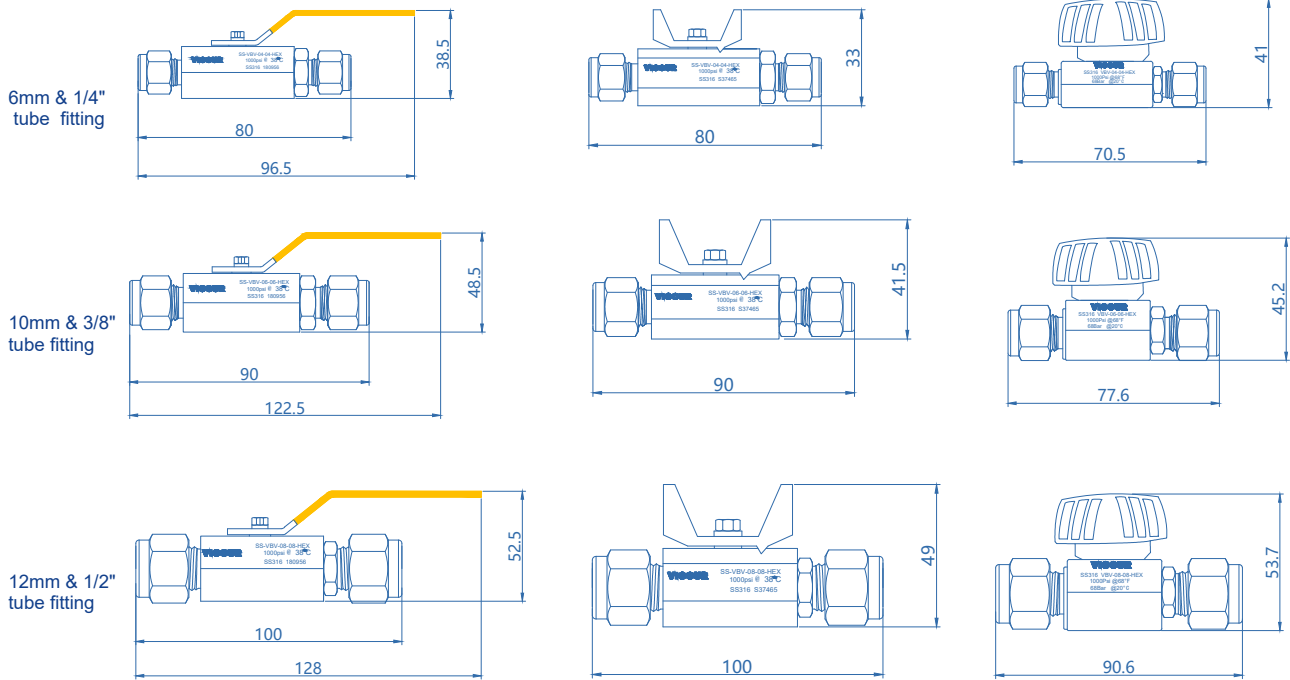

## Ordering Information

**SS - VBV3 - 06 - 06 - B - HEX**

### Body Material

SS: 316

### Inlet / Outlet

- 04: 1/4" tube fitting
- 06: 3/8" tube fitting
- 08: 1/2" tube fitting
- 12: 3/4" tube fitting (only for butterfly and yellow handle type)
- 16: 1" tube fitting (only for butterfly and yellow handle type)
- 6M: 6mm tube fitting
- 10M: 10mm tube fitting
- 12M: 12mm tube fitting
- F4: 1/4" female NPT
- F8: 1/2" female NPT
- F12: 3/4" female NPT (only for butterfly and yellow handle type)
- F16: 1" female NPT (only for butterfly and yellow handle type)

### Handle Option

- None: Yellow handle
- B: Butterfly handle
- S: Short handle

## Product Features

- Stainless steel, carbon steel materials
- Wide selection of seat materials, PTFE is standard
- On-off (2-way) valves
- Compensating seat design
- Live-loaded, two-piece stem packing
- Quarter-turn actuation
- Variety of end connections in 1/8 to 2 in. and 6 to 25 mm sizes
- Optional vent porting



## Pressure-Temperature Ratings

Series	VBV4A/4B/4C	VBV4D/4E	VBV4A/4B/4C/4D/4E
Material	316		304
Temperature, °F (°C)	Working Pressure, psig (bar)		
-20 (-28) to 100 (37)	2200 (151)	1500 (103)	2200 (151)
150 (65)	1850 (127)	1210 (83.3)	1850 (127)
200 (93)	1500 (103)	930 (64.0)	1500 (103)
250 (121)	1150 (79.2)	880 (60.6)	1150 (79.2)
300 (148)	800 (55.1)	780 (53.7)	800 (55.1)
350 (176)	560 (38.5)	560 (38.5)	560 (38.5)
400 (204)	330 (22.7)	330 (22.7)	330 (22.7)
450 (232)	100 (6.8)	100 (6.8)	100 (6.8)

## Dimensions

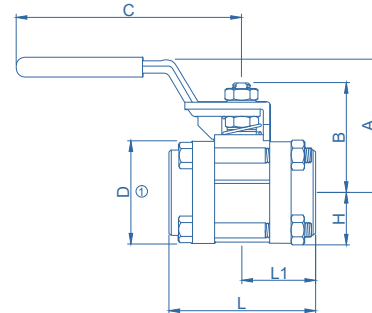

### Female NPT End Connections

Size in.	Ordering Number	Orifice	Cv	Dimensions, in. (mm)						
				L	L1	A	B	H	C	D <sup>①</sup>
1/8	SS-VBV4A-F2	0.281 (7.1)	3.8	2.16 (54.9)	1.08 (27.4)	1.66 (42.2)	1.26 (32.0)	0.68 (17.3)	2.37 (60.2)	1.35 (34.3)
1/4	SS-VBV4A-F4	0.281 (7.1)	3.8	2.16 (54.9)	1.08 (27.4)	1.66 (42.2)	1.26 (32.0)	0.68 (17.3)	2.37 (60.2)	1.35 (34.3)
3/8	SS-VBV4B-F6	0.516 (13.1)	12	2.70 (68.6)	1.35 (34.3)	2.35 (59.7)	1.79 (45.5)	0.89 (22.6)	4.50 (114)	1.78 (45.2)
1/2	SS-VBV4B-F8	0.516 (13.1)	12	2.70 (68.6)	1.35 (34.3)	2.35 (59.7)	1.79 (45.5)	0.89 (22.6)	4.50 (114)	1.78 (45.2)
3/4	SS-VBV4C-F12	0.875 (22.2)	31	3.59 (91.2)	1.80 (45.7)	2.94 (74.7)	2.52 (64.0)	1.25 (31.8)	6.00 (152)	2.50 (63.5)
1	SS-VBV4C-F16	0.875 (22.2)	38	3.59 (91.2)	1.80 (45.7)	2.94 (74.7)	2.52 (64.0)	1.25 (31.8)	6.00 (152)	2.50 (63.5)
1 1/4	SS-VBV4D-F20	1.250 (31.8)	90	4.39 (112)	2.19 (55.6)	4.03 (102)	3.14 (79.8)	1.53 (38.9)	9.14 (232)	3.06 (77.7)
1 1/2	SS-VBV4D-F24	1.250 (31.8)	100	4.39 (112)	2.19 (55.6)	4.03 (102)	3.14 (79.8)	1.53 (38.9)	9.14 (232)	3.06 (77.7)
2	SS-VBV4E-F32	1.500 (38.1)	130	4.94 (125)	2.47 (62.7)	4.16 (106)	3.36 (85.3)	1.74 (44.2)	9.14 (232)	3.47 (88.1)

① Height and width of B through E series flanges. Height of A series flange is 1.59 in. (40.4 mm); width is D dimension.

# Ball Valve / Kugelhahn

## VBV4 Series

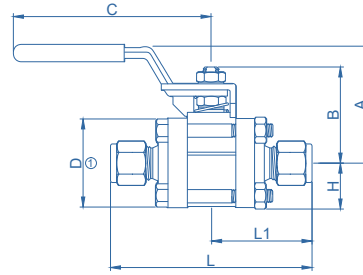

### Tube Fitting End Connections

Size	Ordering Number	Orifice in. (mm)	Cv	Dimensions, in. (mm)						
				L	L1	A	B	H	C	D <sup>①</sup>
1/4"	SS-VBV4A-04	0.188 (4.8)	1.2	3.17 (80.5)	1.59 (40.4)	1.66 (42.2)	1.26 (32.0)	0.68 (17.3)	2.37 (60.2)	1.35 (34.3)
3/8"	SS-VBV4A-06	0.281 (7.1)	3.8	3.17 (80.5)	1.59 (40.4)	1.66 (42.2)	1.26 (32.0)	0.68 (17.3)	2.37 (60.2)	1.35 (34.3)
1/2"	SS-VBV4B-08	0.406 (10.3)	7.5	4.04 (103)	2.02 (51.3)	2.35 (59.7)	1.79 (45.5)	0.89 (22.6)	4.50 (114)	1.78 (45.2)
3/4"	SS-VBV4B-12	0.516 (13.1)	13.6	4.04 (103)	2.02 (51.3)	2.35 (59.7)	1.79 (45.5)	0.89 (22.6)	4.50 (114)	1.78 (45.2)
1"	SS-VBV4C-16	0.875 (22.2)	40	5.36 (136)	2.68 (68.1)	2.94 (74.7)	2.52 (64.0)	1.25 (31.8)	6.00 (152)	2.50 (63.5)
1 1/2"	SS-VBV4D-24	1.250 (31.8)	100	7.59 (193)	3.79 (96.3)	4.03 (102)	3.14 (79.8)	1.53 (38.9)	9.14 (232)	3.06 (77.7)
2"	SS-VBV4E-32	1.500 (38.1)	130	9.95 (253)	4.97 (126)	4.16 (106)	3.36 (85.3)	1.74 (44.2)	9.14 (232)	3.47 (88.1)
6mm	SS-VBV4A-6M	0.188 (4.8)	1.2	3.17 (80.5)	1.59 (40.4)	1.66 (42.2)	1.26 (32.0)	0.68 (17.3)	2.37 (60.2)	1.35 (34.3)
8mm	SS-VBV4A-8M	0.250 (6.4)	2.5	3.17 (80.5)	1.59 (40.4)	1.66 (42.2)	1.26 (32.0)	0.68 (17.3)	2.37 (60.2)	1.35 (34.3)
10mm	SS-VBV4A-10M	0.281 (7.1)	3.8	3.20 (81.3)	1.60 (40.6)	1.66 (42.2)	1.26 (32.0)	0.68 (17.3)	2.37 (60.2)	1.35 (34.3)
12mm	SS-VBV4B-12M	0.375 (9.5)	7.5	4.04 (103)	2.02 (51.3)	2.35 (59.7)	1.79 (45.5)	0.89 (22.6)	4.50 (114)	1.78 (45.2)
18mm	SS-VBV4B-18M	0.516 (13.1)	13.6	4.04 (103)	2.02 (51.3)	2.35 (59.7)	1.79 (45.5)	0.89 (22.6)	4.50 (114)	1.78 (45.2)
25mm	SS-VBV4C-25M	0.875 (22.2)	40	5.36 (136)	2.68 (68.1)	2.94 (74.7)	2.52 (64.0)	1.25 (31.8)	6.00 (152)	2.50 (63.5)

① Height and width of B through E series flanges. Height of A series flange is 1.59 in. (40.4 mm); width is D dimension.

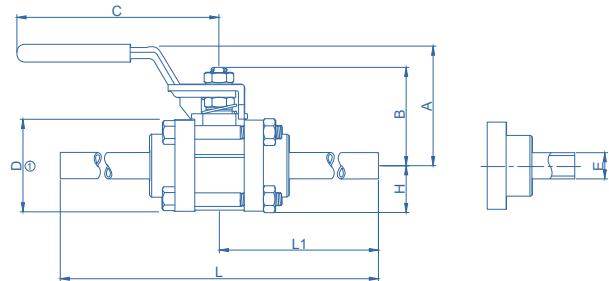

### Tube Extension End Connections

Size in.	wall thickness	Ordering Number	Orifice in. (mm)	Cv	Dimensions, in. (mm)							
					E	L	L1	A	B	H	C	D <sup>①</sup>
1/4	0.035	SS-VBV4A-TW4T35	0.180 (4.6)	1.1	0.250 (6.4)	8.12 (206)	4.05 (103)	1.66 (42.2)	1.26 (32.0)	0.68 (17.3)	2.37 (60.2)	1.35 (34.3)
3/8	0.035	SS-VBV4A-TW6T35	0.281 (7.1)	3.8	0.375 (9.5)	8.12 (206)	4.05 (103)	1.66 (42.2)	1.26 (32.0)	0.68 (17.3)	2.37 (60.2)	1.35 (34.3)
1/2	0.049	SS-VBV4B-TW8T49	0.402 (10.2)	7.2	0.500 (12.7)	8.51 (216)	4.26 (108)	2.35 (59.7)	1.79 (45.7)	0.89 (22.6)	4.50 (114)	1.78 (45.2)
1/2	0.065	SS-VBV4B-TW8T65	0.370 (9.4)	6.1	0.500 (12.7)	8.51 (216)	4.26 (108)	2.35 (59.7)	1.79 (45.5)	0.89 (22.6)	4.50 (114)	1.78 (45.2)
3/4	0.065	SS-VBV4C-TW12T65	0.620 (15.7)	18	0.750 (19.1)	9.53 (242)	4.77 (121)	2.94 (74.7)	2.52 (64.0)	1.25 (31.8)	6.00 (152)	2.50 (63.5)
1	0.065	SS-VBV4D-TW16T65	0.870 (22.1)	36	1.000 (25.4)	9.53 (242)	4.77 (121)	2.94 (74.7)	2.52 (64.0)	1.25 (31.8)	6.00 (152)	2.50 (63.5)
1 1/2	0.065	SS-VBV4D-TW24T65	1.250 (31.8)	100	1.500 (38.1)	10.5 (267)	5.27 (134)	4.03 (102)	3.14 (79.8)	1.53 (38.9)	9.14 (232)	3.06 (77.7)
2	0.065	SS-VBV4E-TW32T65	1.500 (38.1)	130	2.000 (50.1)	11.3 (287)	5.65 (144)	4.16 (106)	3.36 (85.3)	1.74 (44.2)	9.14 (232)	3.47 (88.1)

① Height and width of B through E series flanges. Height of A series flange is 1.59 in. (40.4 mm); width is D dimension.

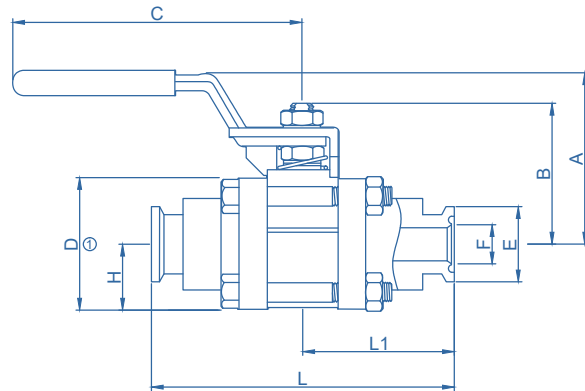

## Sanitary Fitting End Connections

Size in.	Ordering Number	Orifice in. (mm)	Cv	Dimensions, in. (mm)								
				E	F	L	L1	A	B	H	C	D <sup>①</sup>
TS Series												
1/2	SS-VBV4B-TSC8	0.370 (9.4)	7.5	0.99 (25.1)	0.3 (9.4)	3.58 (8.9)	1.75 (44.4)	2.35 (59.7)	1.79 (45.5)	0.89 (22.6)	4.5 (114)	1.78 (45.2)
3/4	SS-VBV4C-TSC12	0.516 (13.1)	15	0.99 (1.0)	0.62 (15.7)	3.5 (88.9)	1.75 (44.4)	2.35 (59.7)	1.79 (45.5)	0.89 (22.6)	4.5 (114)	1.78 (45.2)
1	SS-VBV4E-TSC16	0.873 (22.2)	42	1.99 (50.5)	0.87 (22.1)	4.5 (114)	2.25 (57.2)	2.94 (74.7)	2.52 (64)	1.25 (31.8)	6 (152)	2.5 (63.5)
1 1/2	SS-VBV4B-TSC24	1.250 (31.8)	100	1.99 (50.5)	1.37 (34.8)	5.5 (140)	2.75 (69.9)	4.03 (102)	3.14 (79.8)	1.53 (38.9)	9.14 (232)	3.06 (77.7)
2	SS-VBV4D-TSC32	1.500 (38.1)	130	2.52 (64)	1.87 (47.5)	6.25 (159)	3.12 (79.2)	4.16 (106)	3.36 (85.3)	1.74 (44.2)	9.14 (232)	3.47 (88.1)
SC Series												
1/2	SS-VBV4B-SC8	0.281 (7.1)	7.1	0.99 (25.1)	0.37 (9.4)	3.56 (90.4)	1.78 (45.2)	1.66 (42.2)	1.26 (32)	0.68 (17.3)	2.37 (60.2)	1.35 (34.3)
3/4	SS-VBV4C-SC12	0.516 (13.1)	13.2	0.99 (25.1)	0.62 (15.7)	4.06 (103)	2.03 (51.5)	2.35 (59.7)	1.79 (45.1)	0.89 (22.6)	4.5 (114)	1.78 (45.2)
1	SS-VBV4E-SC16	0.872 (22.1)	42	1.99 (50.5)	0.87 (22.1)	4.5 (114)	2.25 (57.2)	2.94 (74.7)	2.52 (64)	1.25 (31.8)	6 (152)	2.5 (63.5)
1 1/2	SS-VBV4B-SC24	1.250 (31.8)	100	1.98 (50.3)	1.37 (34.8)	5.5 (140)	2.75 (69.9)	4.03 (102)	3.14 (79.8)	1.53 (38.9)	9.14 (232)	3.06 (77.7)
2	SS-VBV4D-SC32	1.500 (38.1)	130	2.52 (64)	1.87 (47.5)	6.25 (159)	3.12 (79.2)	4.16 (106)	3.36 (85.3)	1.74 (44.2)	9.14 (232)	3.47 (88.1)

① Height and width of B through E series flanges. Height of A series flange is 1.59 in. (40.4 mm); width is D dimension.

## Ordering Information

### SS - VBV4A - 06 - options

#### Body Material

SS: 316  
S4: 304

#### Serial Number

A: A series  
B: B series  
C: C series  
D: D series  
E: E series

#### Seat Material

More material, please contact factory

#### End Connections

Tube fitting: see above tables  
Female NPT : see above tables  
Tube weld: see above tables  
Sanitary: see above tables



# Needle Valve / Nadelventile

## VNV Series

### Product Features

- Live-loaded packing system
- Vee stem, regulating stem, soft-seat stem are optional
- Compact design
- Panel mounting
- Straight, angle, and cross flow patterns
- Working pressures up to 5000psig (345bar)

### Typical Applications

- Component Testing
- Calibration Systems
- Laboratory Pressure Control
- High Pressure Sampling Systems
- Service & Test Equipment



### Technical Data

Type:	needle valve
Inlet pressure:	Max.5000psig (345bar)
Materials:	
Body:	see ordering info
Seat:	metal to metal
Diaphragm:	Hastelloy <sup>®</sup> C276
Filter:	316
Inlet/outlet connection:	see ordering info
Temperature:	-54°C to +232°C
Leak rate:	0.1 std cc/min
Orifice:	see ordering info
Weight:	0.1 Kg

### Ordering Information

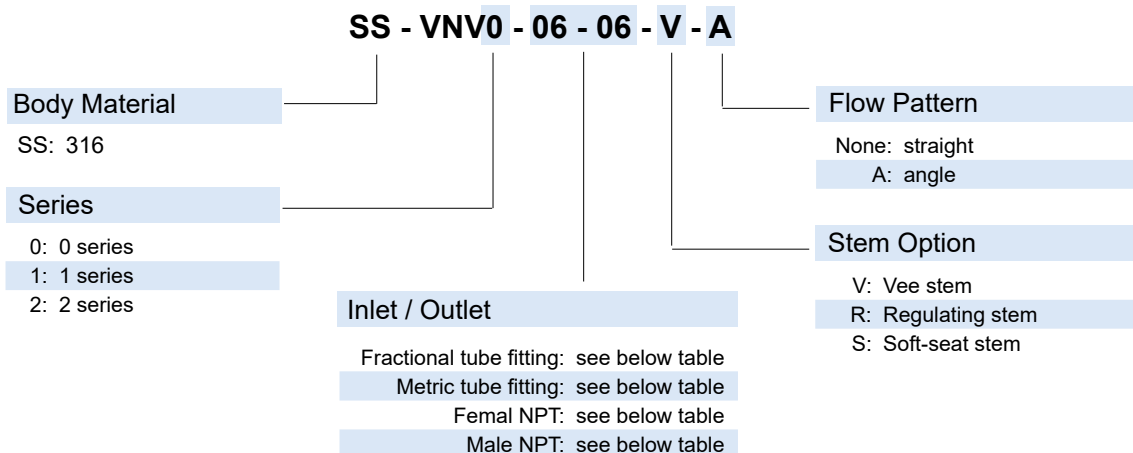

# Nadelventile / Needle Valve VNV Series

## Dimensions

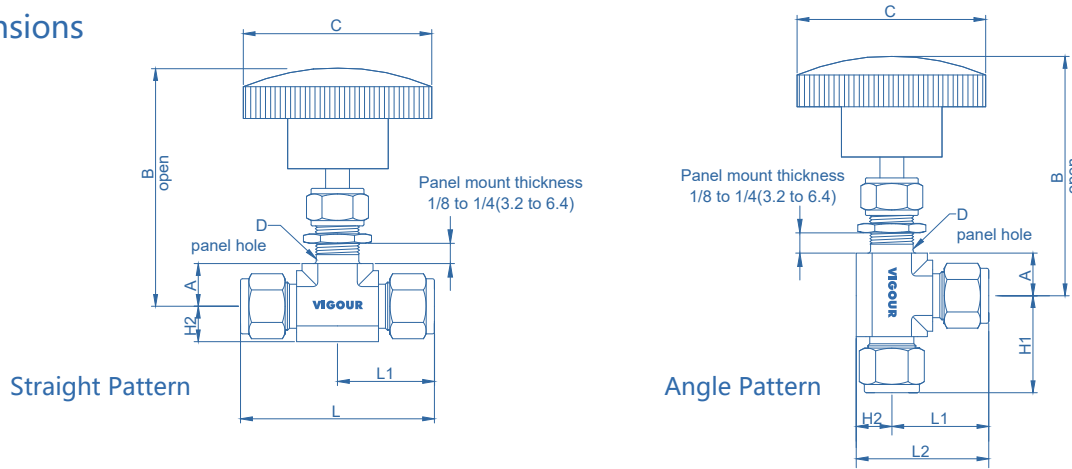

End Connections	Cv	Orifice in.	Ordering Number	Dimensions, in. (mm)								
				L	L1	H1	L2	A	H2	C	D	B
Fractional tube fittings												
1/8 in.	0.09	0.080 (2.0)	SS-VNV0-02-02	1.94 (49.3)	0.98 (24.9)	1.29 (32.8)	0.44 (11.2)	0.31 (7.9)	1 (25.4)	0.47 (11.9)	2.28 (57.9)	
1/4 in.	0.37	0.172 (4.4)	SS-VNV1-04-04	2.27 (57.6)	1.13 (28.7)	1.51 (38.4)			0.38 (9.7)	1.38 (35.1)	0.53 (13.5)	2.50 (63.5)
3/8 in.	0.73	0.250 (6.4)	SS-VNV1-06-06	2.58 (65.5)	1.29 (32.8)	1.79 (45.5)	0.55 (14.0)	0.50 (12.7)	1.88 (47.8)	0.78 (19.8)	2.97 (75.4)	
1/2 in.			SS-VNV1-08-08	2.80 (71.1)	1.40 (35.6)	1.90 (48.3)						
1/2 in.	1.80	0.375 (9.5)	SS-VNV2-08-08	3.80 (96.5)	1.90 (48.3)	2.65 (67.3)	0.75 (19.1)	3.00 (76.2)	1.03 (26.2)	3.91 (99.3)		
3/4 in.			SS-VNV2-12-12									
Metric tube fittings												
3 mm	0.09	0.080 (2.0)	SS-VNV0-3M-3M	1.94 (49.3)	0.98 (24.9)	1.29 (32.8)	0.44 (11.2)	0.31 (7.9)	1.00 (25.4)	0.48 (12.2)	2.28 (57.9)	
6 mm	0.37	0.172 (4.4)	SS-VNV1-6M-6M	2.27 (57.6)	1.13 (28.7)	1.51 (38.4)			0.38 (9.7)	1.38 (35.1)	0.53 (13.5)	2.50 (63.5)
8 mm			SS-VNV1-8M-8M	2.34 (59.4)	1.17 (29.7)	1.54 (39.1)						
10 mm	0.73	0.250 (6.4)	SS-VNV1-10M-10M	2.60 (66.0)	1.30 (33.0)	1.80 (45.7)	0.55 (14.0)	0.50 (12.7)	1.88 (47.8)	0.78 (19.8)	2.97 (75.4)	
12 mm			SS-VNV1-12M-12M	2.80 (71.1)	1.40 (35.6)	1.90 (48.3)						
Female NPT												
1/8 in.	0.09	0.080 (2.0)	SS-VNV0-F2-F2	1.88 (47.8)	0.94 (23.9)	1.25 (31.8)	0.44 (11.2)	0.31 (7.9)	1.00 (25.4)	0.47 (11.9)	2.28 (57.9)	
1/8 in.	0.37	0.172 (4.4)	SS-VNV1-F2-F2	1.62 (41.1)	0.81 (20.6)	1.19 (30.2)			0.38 (9.7)	1.38 (35.1)	0.53 (13.5)	2.50 (63.5)
1/4 in.	0.73	0.250 (6.4)	SS-VNV1-F4-F4	2.12 (53.8)	1.06 (26.9)	1.56 (39.6)	0.55 (14.0)	0.50 (12.7)	1.88 (47.8)	0.78 (19.8)	2.97 (75.4)	
3/8 in.	1.80	0.375 (9.5)	SS-VNV2-F6-F6	3.00 (76.2)	1.50 (38.1)	2.25 (57.2)	0.75 (19.1)	3.00 (76.2)	1.03 (26.2)	3.88 (98.6)		
1/2 in.			SS-VNV2-F8-F8									
Male NPT												
1/8 in.	0.09	0.080 (2.0)	SS-VNV0-M2-M2	1.50 (38.1)	0.75 (19.1)	1.06 (26.9)	0.44 (11.2)	0.31 (7.9)	1.00 (25.4)	0.47 (11.9)	2.28 (57.9)	
1/8 in.	0.37	0.172 (4.4)	SS-VNV1-M2-M2	1.62 (41.1)	0.81 (20.6)	1.19 (30.2)			0.38 (9.7)	1.38 (35.1)	0.53 (13.5)	2.50 (63.5)
1/4 in.			SS-VNV1-M4-M4	1.97 (50.0)	0.98 (24.9)	1.36 (34.5)						
3/8 in.	0.73	0.250 (6.4)	SS-VNV1-M6-M6	2.25 (62.5)	1.12 (28.4)	1.62 (41.1)	0.55 (14.0)	0.50 (12.7)	1.88 (47.8)	0.78 (19.8)	2.97 (75.4)	
1/2 in.	1.80	0.375 (9.5)	SS-VNV2-M8-M8	3.00 (76.2)	1.50 (38.1)	2.25 (57.2)	0.75 (19.1)	3.00 (76.2)	1.03 (26.2)	3.88 (98.6)		

# Calibration Gas Disposable Aluminum Cylinder Valve

## VCV-16 Series

### Product Features

- Disposable Calibration Gas Cylinder Valve
- Brass chrome plated body or stainless steel body

### Typical Applications

- Designed for calibration applications.



### Technical Data

Inlet pressure :	Max.200 bar
Body material:	see ordering info
Inlet connection:	1"-14UNF / 3/4"-16UNF
Outlet connection:	5/8"-18UNF
Leak rate	bubble-tight
Temperature range:	-20°C to +70°C
Weight:	0.10 kg

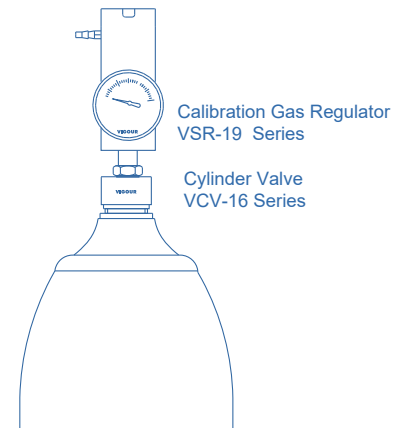

### Dimensions (mm)

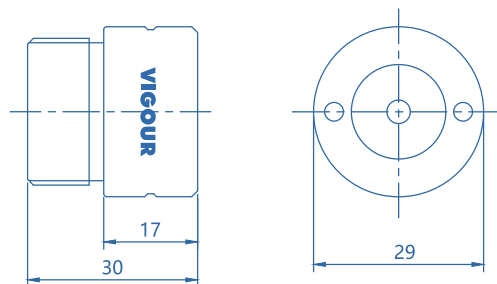

### Ordering Information

**VCV - 16 S - 40 - A**

#### Body Material

S: 316L

C: Chrome Plated Brass

#### Inlet Pressure

40: 40 bar

200: 200 bar

#### Inlet connection:

None: 1"14 UNF

A: 3/4"16 UNF

## Product Features

- One directional flow indicated by arrow on body.
- For high flow capability and low pressure drop.
- Working temperature range:  
-20°C to + 165°C .
- Cleaned for use in oxygen service .
- Max Inlet pressure : 200bar



## Typical Applications

Inline check valves for leak free operation in gas service.

## Typical Data

Body	316L
Cracking pressure	1 psig
Spring	Stainless Steel
Piston	Stainless Steel
Seat	Viton®

## Dimensions (mm)

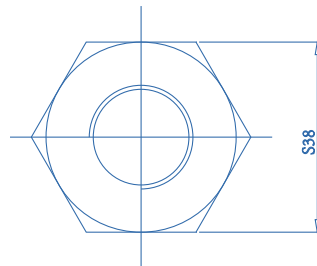
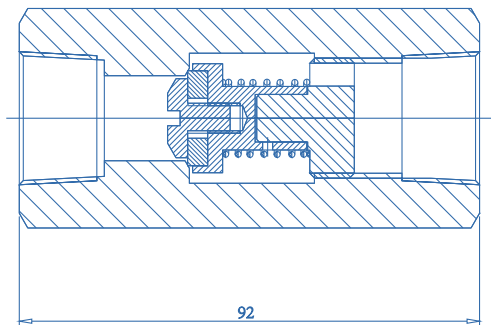

## Ordering Information

Model No	Inlet/Outlet Connection	Materials
VCV-S-F12	3/4"NPT(F) x 3/4"NPT(F)	Stainless Steel
VCV-B-F12	3/4"NPT(F) x 3/4"NPT(F)	Brass

# Check Valves / Rückschlagventile

## VCV1 Series

### Product Features

- Compact designed check valves
- Viton® (FKM) O-rings are standard(option : Kalrez® (FFKM) )
- Pressure rating: 200 bar

### Typical Applications

- Designed for instrumentation panels and systems



### Technical Data

Working pressure:	200 bar
Cracking pressure:	1 psi
Body material:	see ordering info
Inlet/outlet connection:	see ordering info
O-ring:	Viton® (FKM) standard Kalrez® (FFKM) option
Leak rate	bubble-tight

### Ordering Information

**VCV1 - S - 04 - 04 - N2**

Material

S: 316L

Inlets / Outlets

02: 1/8" Tube fitting

04: 1/4" Tube Fitting

06: 3/8" Tube fitting

12: 3/4" Tube Fitting

16: 1" Tube fitting

Type of Gas

Please specify type of gas

### Product Features

- Compact designed check valves
- Viton® (FKM) O-rings are standard(option : Kalrez® (FFKM) )
- Pressure rating: 300 bar
- Cracking pressure :0.02 bar

### Typical Applications

- Designed for instrumentation panels and systems



### Technical Data

Working pressure:	300 bar
Cracking pressure:	1 psi
Body material:	see ordering info
Inlet/outlet connection:	see ordering info
O-ring:	Viton® (FKM) standard Kalrez® (FFKM) option
Leak rate	bubble-tight

### Dimensions (mm)

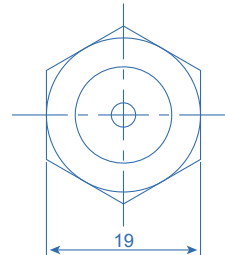
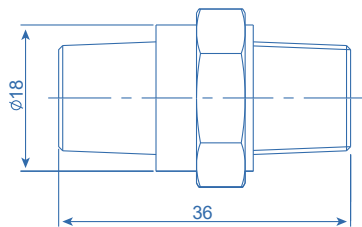

### Ordering Information

**VCV2 - S - M4 - M4 - N2**

#### Material

- S: 316L
- C: Chrome Plated Brass

#### Inlets

- M4: 1/4"NPT(M)
- O4: 1/4" Tube fitting

#### Type of Gas

Please specify type of gas

#### Outlets

- M4: 1/4"NPT(M)

# Relief Valve / Abblaseventil

## VSV1 Series

### Product Features

- Relief valve for low pressure service
- Factory tested for proper set and resealing performance.
- Tested for proof and burst.



### Technical Data

Set pressure:	1-50 bar
Body material:	see ordering info
Inlet/outlet connection:	1/4"NPT(M) / 1/4"NPT(F)
O-ring:	Viton® (FKM) standard Kalrez® (FFKM) option
Leak rate:	10 <sup>-8</sup> mbar l/s He
Temperature:	-30°C - 74°C
Weight:	0.05 kg

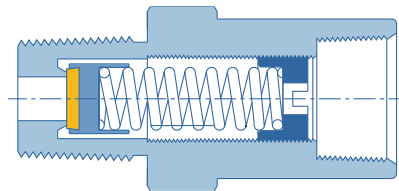

### Ordering Information

VSV1 - S - 16 - N<sub>2</sub>

#### Body Material

- S: 316L
- C: Chrome Plated Brass
- B: Brass

#### Pressure

- 6: 1 to 6 bar
- 16: 6 to 16 bar
- 26: 16 to 26 bar
- 36: 26 to 36 bar
- 50: 36 to 50 bar

#### Type of Gas

Please specify gas type

# proportionales Entlastungsventil / Proportional Relief Valve VSV2 Series

## Product Features

- Liquid or gas service
- Set pressures from 10 to 6000 psig (0.7 to 413 bar)
- 1/4 and 1/2 in. and 6 to 12 mm end connections
- Identifying colored springs for each pressure range
- SS 316L construction



## Technical Data

### Pressure-Temperature Ratings

Series	VSV2			VSV2A			VSV2B & VSV2C		
Inlet Working Pressure <sup>①</sup>	6000 psig (413 bar);			6000 psig (413 bar)			300 psig (20.6 bar)		
Outlet Working Pressure <sup>①</sup>	1500psig (103 bar)			2500 psig (172 bar)			225 psig (15.5 bar)		
Set Pressure	50 to 6000 psig (3.4 to 413 bar)			50 to 1500 psig (3.4 to 103 bar)			10 to 225 psig (0.7 to 15.5 bar)		
Seal Material	Fluorocarbon FKM	EZBR	EPDM	Fluorocarbon FKM	EZBR	EPDM	Fluorocarbon FKM	EZBR	EPDM
Temperature, °F (°C)	Maximum Set Pressure, psig (bar)								
-40 (-40)	—	—	—	—	—	—	—	—	—
-30 (-34)									
-10 (-23)									
0 (-17)									
10 (-12)	6000 (413)	6000 (413)	6000 (413)	1500 (103)	1500 (103)	1500 (103)	225 (15.5)	225 (15.5)	225 (15.5)
25 (-4)									
30 (-1)									
40 (4)									
50 (10)	5580	5580	5580	1500 (103)	1500 (103)	1500 (103)	225 (15.5)	225 (15.5)	225 (15.5)
70 (20)									
150 (65)									
200 (93)									
250 (121)	4910	4910	4910	1500 (103)	1500 (103)	1500 (103)	225 (15.5)	225 (15.5)	225 (15.5)
275 (135)									
300 (148)	—	—	—	—	—	—	—	—	—

### Testing

Every relief valve is tested for set and resealing performance.

Series	Test Set Pressure psig (bar)	Minimum Resealing Pressure as a Percentage
VSV2B	10 to 20 (0.7 to 1.3)	50
VSV2C	175 to 225 (12.0 to 15.5)	91
VSV2	100 to 200 (6.8 to 13.7)	50
VSV2A	850 to 1000 (58.5 to 68.9)	84



# Proportional Relief Valve / proportionales Entlastungsventil

## VSV2 Series

### Dimensions (mm)

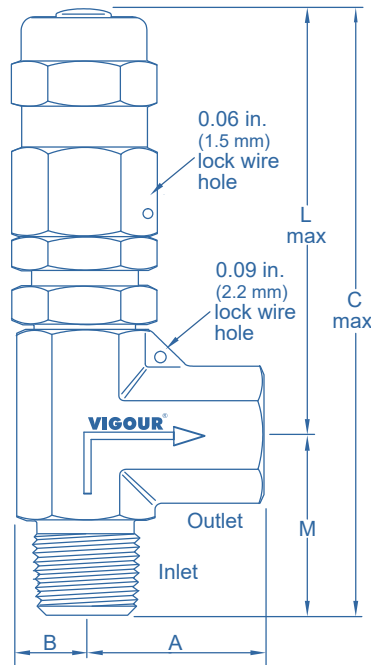

Dimensions shown with tube fitting nuts finger-tight.

### Low-Pressure Valves

- Service up to 300 psig (20.6 bar)
- One spring for the full set pressure range
- Valves available factory-set to a specified set pressure

End Connections		Ordering Number	Dimensions, in. (mm)				
Inlet/Outlet	Size		L	M	A	B	C
VSV2B series: 0.19 in. (4.8 mm) fully open orifice (set pressure range: 0.7~225 bar)							
tube fittings	1/4 in.	S-VSV2B-*-04-04	2.70 (68.6)	1.44 (36.6)	1.60 (40.6)	0.43 (10.9)	4.14 (105)
	6 mm	S-VSV2B-*-6M-6M					
	8 mm	S-VSV2B-*-8M-8M					
Male NPT / tube fitting	1/4 in.	S-VSV2B-*-F4-04		1.19 (30.2)	1.60 (40.6)		3.89 (98.8)
Male NPT/ female NPT	1/4 in.	S-VSV2B-*-M4-F4	1.19 (30.2)	1.17 (29.7)	3.89 (98.8)		
VSV2C series: 0.25 in. (6.4 mm) fully open orifice (set pressure range: 0.7~225 bar)							
tube fittings	1/2 in.	S-VSV2C-*-08-08	4.09 (104)	1.83 (46.5)		0.50 (12.7)	5.92 (150)
	12 mm	S-VSV2C-*-12M-12M					
Male NPT / tube fitting	1/2 in.	S-VSV2C-*-M8-08		1.43 (36.3)	1.83 (46.5)		5.52 (140)
Male NPT/ female NPT	1/2 in.	S-VSV2C-*-M8-F8		1.43 (36.3)	1.43 (36.3)		5.52 (140)

\* set pressure, the desinator according to the ordering information

# proportionales Entlastungsventil / Proportional Relief Valve

## VSV2 Series

### High-Pressure Valves

- Service up to 6000 psig (413 bar)
- Multiple springs for a selection of set pressure ranges
- Valves available factory-set to a specified set pressure

End Connections		Ordering Number	Dimensions, in. (mm)				
Inlet/Outlet	Size		L	M	A	B	C
VSV2 series: 0.14 in. (3.6 mm) fully open orifice (set pressure range: 3.5~400 bar)							
tube fittings	1/4 in.	S-VSV2-*-04-04	2.70 (68.6)	1.44 (36.6)	1.60 (40.6)	0.43 (10.9)	4.14 (105)
	6 mm	S-VSV2-*-6M-6M					
	8 mm	S-VSV2-*-8M-8M					
Male NPT/ tube fitting	1/4 in.	S-VSV2-*-M4-04		1.19 (30.2)	1.60 (40.6)		3.89 (98.8)
Male NPT/ female NPT	1/4 in.	S-VSV2-*-M4-F4		1.19 (30.2)	1.17 (29.7)		3.89 (98.8)
VSV2A series: 0.25 in. (6.4 mm) fully open orifice (set pressure range: 3.5~100 bar)							
tube fittings	1/2 in.	S-VSV2A-*-08-08	4.09 (104)	1.83 (46.5)		0.50 (12.7)	5.92 (150)
	12 mm	S-VSV2A-*-12M-12M					
Male NPT/ tube fitting	1/2 in.	S-VSV2A-*-M8-08		1.43 (36.3)	1.83 (46.5)		5.52 (140)
Male NPT/ female NPT	1/2 in.	S-VSV2A-*-M8-F8		1.43 (36.3)	1.43 (36.3)		5.52 (140)

\* set pressure, the desinator accroding to the orering information

## Ordering Information

**S - VSV2 - 50 - 04 - 04 - B**

### Body Material

S: 316L

### Series Code

VSV2: VSV2 series  
 VSV2A: VSV2A series  
 VSV2B: VSV2B series  
 VSV2C: VSV2C series

### Set Pressure

15: 0.7 to 15 bar  
 25: 3.5 to 25 bar  
 50: 25 to 50 bar  
 100: 50 to 100 bar  
 150: 100 to 150 bar  
 200: 150 to 200 bar  
 250: 200 to 250 bar  
 350: 250 to 350 bar  
 400: 350 to 400 bar

### Seal

None: FKM  
 B: NBR  
 E: EPDM  
 N: CR  
 Z: Kalrez®

### Inlets / Outlets

tube fittings: see above tables  
 NPT threads: see above tables

# Flashback Arrestors / Flammenrückschlagsperren

## VFB Series

### Product Features

- Flashback arrestors are designed for oxygen, hydrogen and other flammable or fuel gases.
- Standard with NPT or Tube Fitting inlet and outlet connections make it easy to adapt in various applications.
- Complete with check valve
- 316L sintered elements



VFB50



VFB100-F8

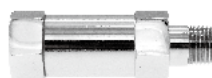

VFB50-A



VFB100-F16



VFB200

### Technical Data

Inlet pressure:	Max.20 bar
Materials:	
Body:	see ordering info
O-ring:	Viton® (FKM)
Inlet / Outlet :	see ordering info

### Flow Chart

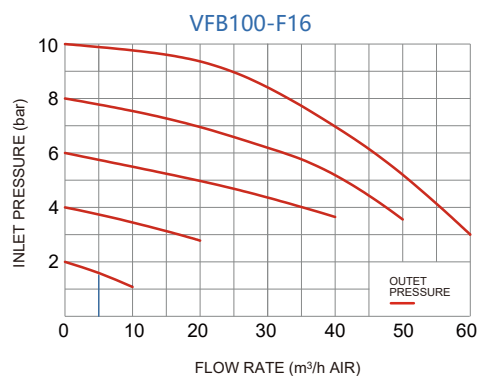
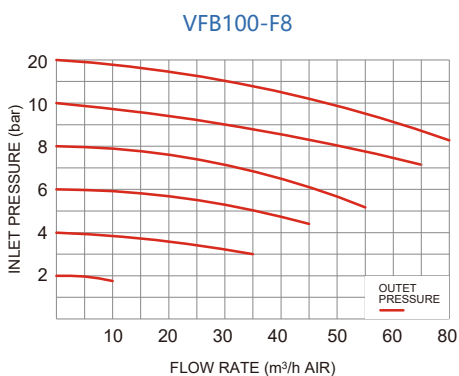
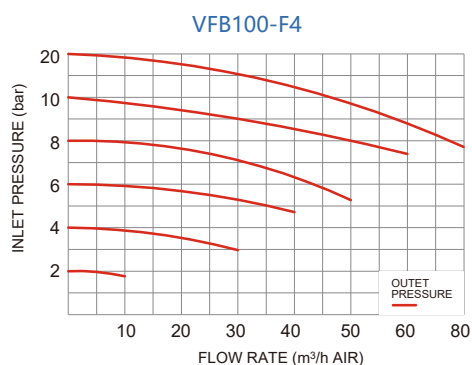
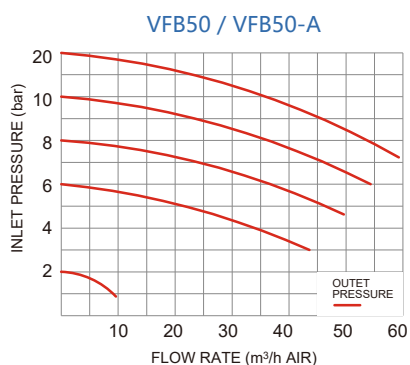

# Flammenrückschlagsperren / Flashback Arrestors

## VFB Series

### Dimensions

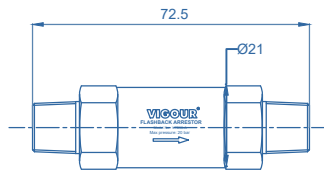

VFB50

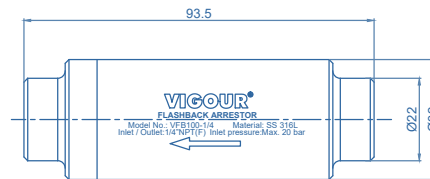

VFB100 1/4" NPT Connection

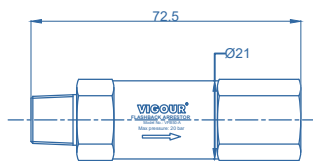

VFB50A

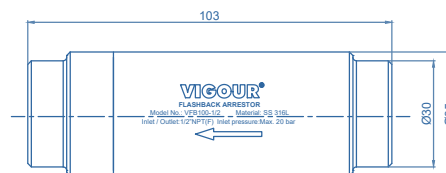

VFB100 1/2" NPT Connection

### Ordering Information

Model No.	Inlet/Outlet Connection	Flow Rate	Materials	Return Valve
VFB50	1/4"NPT(M) x 1/4"NPT(M)	see flowchart	Chrome Plated Brass	CV
VFB50-A	1/4"NPT(M) x 1/4"NPT(F)	see flowchart	Chrome Plated Brass	CV
VFB100-F4	1/4"NPT(F) x 1/4"NPT(F)	see flowchart	SS 316L	CV
VFB100-F8	1/2"NPT(F) x 1/2"NPT(F)	see flowchart	SS 316L	CV
VFB100-F16	1"NPT(F) x 1"NPT(F)	see flowchart	SS 316L	CV
VFB200-DN25	Flange DN25	35~50 m <sup>3</sup> /h	SS 316L	CV optional
VFB200-DN50	Flange DN50	65~100 m <sup>3</sup> /h	SS 316L	CV optional
VFB200-DN100	Flange DN100	150~200 m <sup>3</sup> /h	SS 316L	CV optional
VFB200-DN200	Flange DN200	250~350 m <sup>3</sup> /h	SS 316L	CV optional

# Filters / Filter

## VF Series

The VF Series is an In-Line filtration device.

It will be installed in a system to protect the system components from fluid particles and contaminants.

### Product Features

- Filters
- Maximum pressure: 300 bar
- Filter material: 316L
- Filter Rating: 5  $\mu\text{m}$  standard, more option see below table

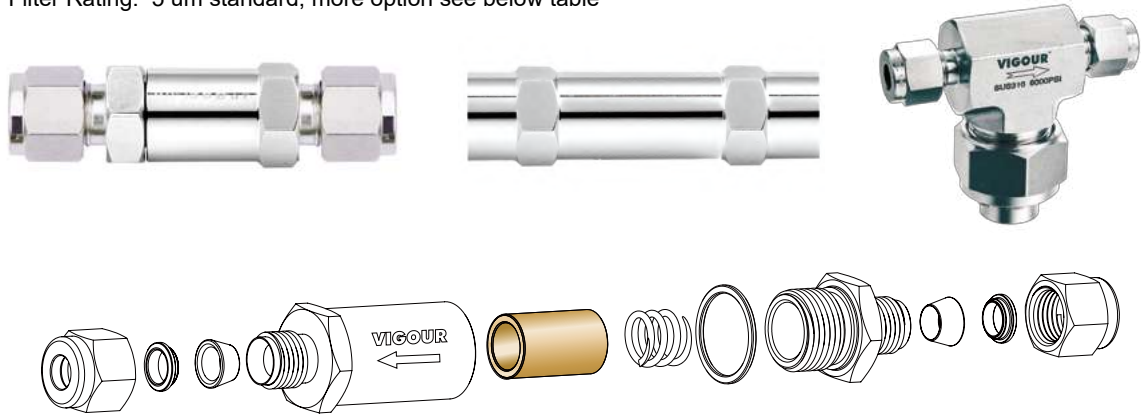

### Flow Rate

#### In-line Type

Element Nominal Pore Size $\mu\text{m}$	Inlet Pressure, ① psig (bar)		
	5 (0.34)	10 (0.68)	15 (1.0)
	Air Flow, std ft <sup>3</sup> /min (std L/min) for 1/8" end connections		
0.2	0.01 (0.3)	0.02 (0.6)	0.05 (1.4)
2	0.20 (5.6)	0.40 (11)	0.60 (17)
5	0.40 (11)	0.60 (17)	0.9 (25)
10	0.50 (14)	0.9 (25)	1 (28)
20	1 (28)	1.7 (47)	2 (56)

#### Tee Type

Element Nominal Pore Size $\mu\text{m}$	Inlet Pressure, ① psig (bar)		
	5 (0.34)	10 (0.68)	15 (1.0)
	Air Flow, std ft <sup>3</sup> /min (std L/min) for 1/8" end connections		
2	0.20 (5.6)	0.40 (11)	0.60 (17)
5	0.40 (11)	0.60 (17)	0.9 (25)
50	1.4 (40)	1.8 (51)	2(57)
80	1.6 (45)	2.0(57)	2.3 (65)

① Outlet is discharged to atmosphere.

### Ordering Information

**VF - S - 04 - 04 - T - 2**

#### Material

S: 316L  
C: Chrome Plated Brass

#### Inlets / Outlets

02: 1/8" tube fitting	3M: 3mm tube fitting	F2: 1/8" female NPT
04: 1/4" tube fitting	6M: 6mm tube fitting	F4: 1/4" female NPT
06: 3/8" tube fitting	8M: 8mm tube fitting	F6: 3/8" female NPT
08: 1/2" tube fitting	10M: 10mm tube fitting	F8: 1/2" female NPT
16: 1" tube fitting	12M: 12mm tube fitting	F12: 3/4" female NPT
		F16: 1" female NPT

#### Nominal Pore Size

0: 0.2  $\mu\text{m}$   
2: 2  $\mu\text{m}$   
5: 5  $\mu\text{m}$   
10: 10  $\mu\text{m}$   
20: 20  $\mu\text{m}$   
50: 50  $\mu\text{m}$   
80: 80  $\mu\text{m}$

#### Type Code

None: In-line type  
T: Tee type

## Product Features

- Connect with contact gauge for monitoring pressure of gases.
- LED light display 2、4、8 gas status
- Sound alarm
- Mute button
- Connection for distance alarm

## Typical Applications

- Component Testing
- Calibration Systems
- Laboratory Pressure Control
- High Pressure Sampling Systems
- Service & Test Equipment



## Technical Data

Gas status: 2 / 4 / 8 gas status

Working voltage: 110~240 VAC

Materials: ABS

Temperature range: -30°C to +74°C

Weight: 1.2 kg

## Dimensions (mm)

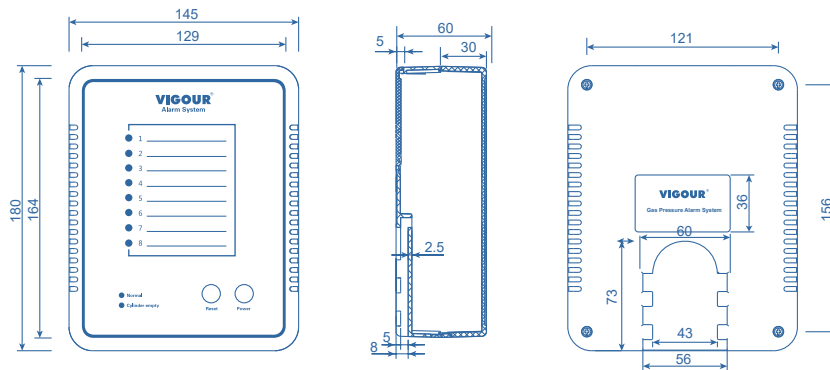

## Ordering Information:

### VAS - 4 -110

Gas Status

2: 2 gas

4: 4 gas

8: 8 gas

Supply Voltage

None:220/240V(standard)

110:110V

# Alarm Systems / Signalgeber VAS100 Series

## Product Features

- Alarm unit come in 8 or 16 channel version
- For connection of 8 or 16 digital input signals such as contact pressure gauges or pressure switches Suitable for transducers in accordance to NAMUR specifications
- All channels are individually programmable as normally closed or normally open contact
- Delay mode (2 sec.) is integrated for all channels
- Potential-free output RS-485
- Visible alarm
- Acoustic alarm
- Aluminum housing for wall mounting



## Technical Data

Type of monitoring	unrestricted
Supply voltage	AC220V (110V) / 50Hz
Power consumption	10 W
Input signal	switch signal
Input capacity	8/16 channels
Output contact	2
Output voltage	DC 12V
Output current	3A
Communication interface	RS-485 (option)
Dimensions	240*200*70 mm

## Dimensions

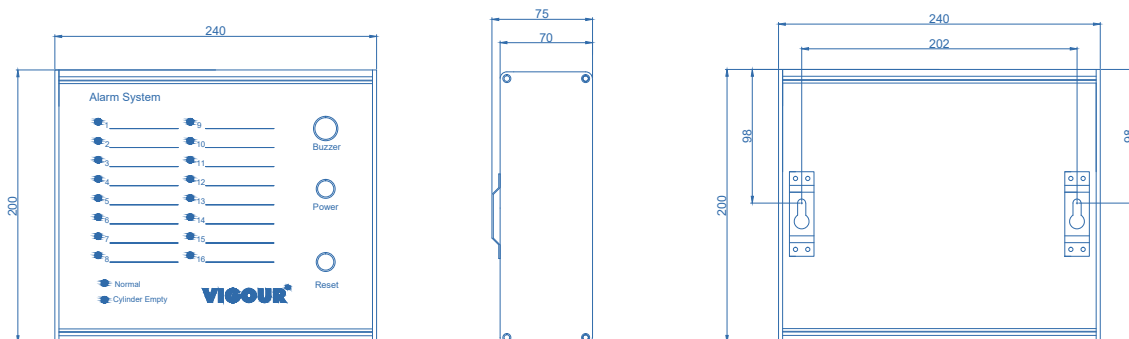

## Ordering Information

**VAS100 - 8 - 110**

Input Capacity

- 8: 8 channels
- 16: 16 channels

Supply Voltage

- 110: AC110V
- None: AC220V

## Product Features

- Real-time display of gas pressure numerical display
- High and low voltage alarm function
- The color of the value box changes to red when warning, and there is a buzzer alarm
- There's a dry line. Action output signal for pressure alarm
- High and low alarm values can be set according to field requirements
- Realized real-time count automatically saved
- With gas curve analysis function
- Alarm fault signal automatically saved



## Technical Data

Type of monitoring	unrestricted
Supply voltage	AC220V(110V) / 50Hz
Power consumption	30W
Input capacity	max.20 channels
Input signal	4-20 mA
Output contact	2
Output voltage	DC 24V
Output current	3A
Communication interface	RS485
Touch screen size	7 inch
Dimension	240*200*70 mm

## Dimensions

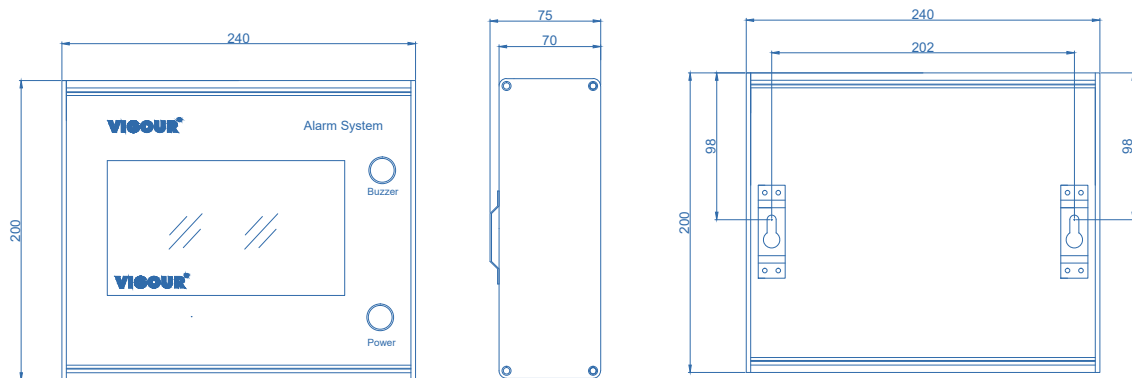

## Ordering Information

**VAS200 - 8 - 110**

Input Capacity

- 6: 6 channels
- 8: 8 channels
- 12: 12 channels
- 16: 16 channels

Supply Voltage

- 110: AC110V
- None: AC220V



# Pressure Switch / Druckschalter

## VSW Series

### Product Features

- High precision
- stainless steel construction
- repeatability, reliability, and stability
- Anti-interference
- NC or NO contacts, easy installation
- Vibration and shock resistance

### Technical Data

Pressure range:	0-25 MPa
Supply voltage:	DC 24V / 12V
Output contact:	NO / NC
Temperature:	-20°C ~ 80°C
Accuracy:	0.5%FS
Ingress protection:	IP65
Connection:	1/4" NPT(M)
Electrical connection:	Mini Hirschmann
Body Material:	304/316
Diaphragm:	Ceramic
Junction box:	Plastic



### Dimensions

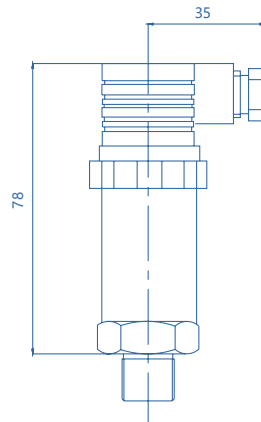

### Ordering Information

**VSW - S - 200**

Material

S4: 304

SS: 316

Set Pressure

60: 60 bar

100: 100 bar

200: 200 bar

250: 250 bar

## Product Features

- High precision
- Stainless steel construction
- SS316L diaphragm
- Available with a variety of output signals
- Broad selection of pressure ranges, Pressure references: gauge (vacuum, positive) and absolute
- repeatability, reliability, and stability
- Anti-interference
- Vibration and shock resistance



## Technical Data

	Standard model	Explosion-proof model
Pressure range:	0~0.6bar 0~600 bar	0~5 bar 0~600 bar
Supply voltage:	DC 12~24V	DC 12~24V
Output signal:	4~20 mA	4~20 mA
Ambient Temperature:	-20°C ~ 85°C	-20°C ~ 85°C
Accuracy:	±0.35%FS (5~100bar) ±0.5%FS (others)	±0.35%FS (5~100bar) ±0.5%FS (others)
Zero point shift:	±0.02%FS	±0.02%FS
Sensitivity shift:	±0.015%FS	±0.015%FS
Response time:	≤2.5ms	≤2.5ms
Diaphragm:	316L	316L
Shell:	304/316	304/316
Explosion-proof:	-	Exd II CT6
Electrical Connection:	Wire/Hirschmann	Wire
Connection:	1/4" NPT(M)	1/4" NPT(M)

## Dimensions

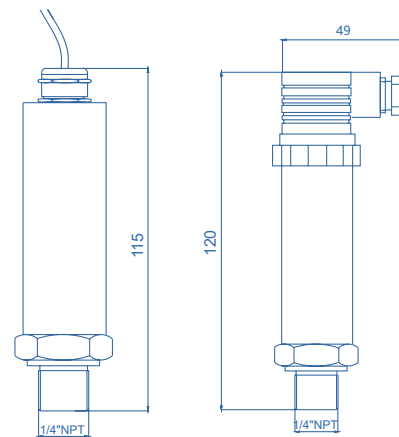

## Ordering Information

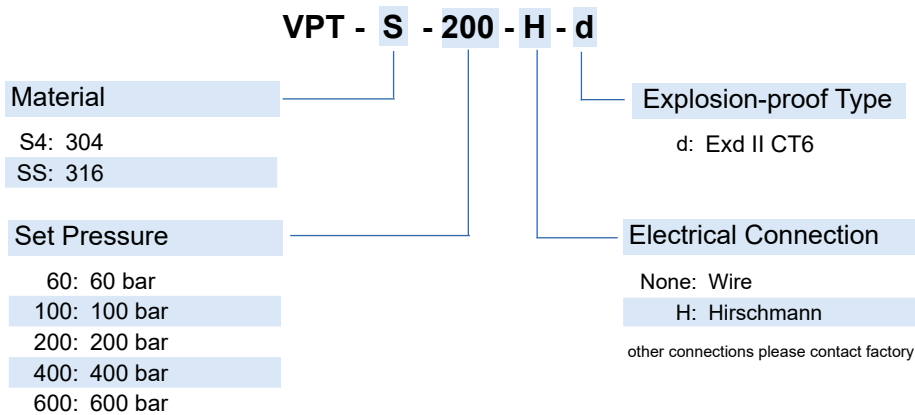

# Pressure Gauges / Manometer VG / VR Series

## Product Features

- Pressure gauges are designed for general and laboratory applications involving the measurement of compressed gases compatible with the materials of construction.
- Gauges are used to monitor pressure of regulators and system.
- Tested for use with oxygen

## Technical Data

Body Material	316L
Type	radial or axial direction
Working Temperature	-40°C ~ 60°C
Nominal diameter	2"
Connection	1/4" NPT(M)
Scale	bar /psig
Window	Laminated safety glass
Switching accuracy	+/- 2.5 % of full scale
Material of connection	SS316L
Leak rate	99.99%



VG Series



VR Series

## Dimensions (mm)

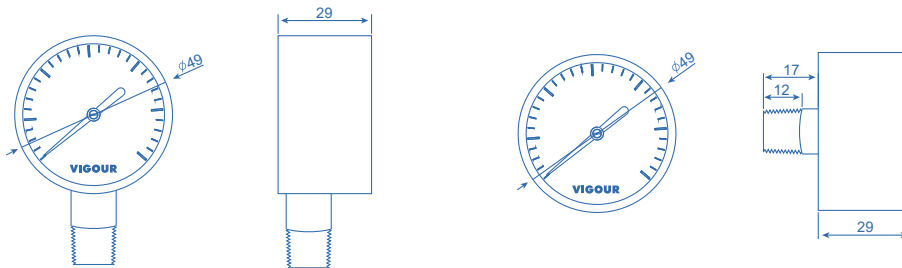

## Ordering Information

Model No.		Pressure Range (bar / psig)	Description
Stainless Steel	Brass Chrome Plated		
VG20S-1.6B-M4	VG20C-1.6B-M4	0~1.6bar/0~23psig	bottom mount 1/4"MNPT inlet connection
VG20S-2.5B-M4	VG20C-2.5B-M4	0~2.5bar / 0~30 psig	
VG20S-4B-M4	VG20C-4B-M4	0~4bar / 0~60psig	
VG20S-6B-M4	VG20C-6B-M4	0~6bar / 0~86psig	
VG20S-10B-M4	VG20C-10B-M4	0~10bar/0~140psig	
VG20S-16B-M4	VG20C-16B-M4	0~16bar / 0~230psig	
VG20S-25B-M4	VG20C-25B-M4	0~25bar / 0~350psig	
VG20S-35B-M4	VG20C-35B-M4	0~35bar/0~500psig	
VG20S-60B-M4	VG20C-60B-M4	0~60bar / 0~860psig	
VG20S-100B-M4	VG20C-100B-M4	0~100bar/0~1500psi	
VG20S-150B-M4	VG20C-150B-M4	0~150bar/0~2000psi	
VG20S-250B-M4	VG20C-250B-M4	0~250bar / 0~3500psig	
VG20S-315B-M4	VG20C-315B-M4	0~315bar/0~4500psi	
VG20S-400B-M4	VG20C-400B-M4	0~400bar / 0~5800psig	
VG20S-V1.6B-M4	VG20C-V1.6B-M4	-1~1.6bar / 30 in Hg VAC ~ 23psig	
VG20S-V2.5B-M4	VG20C-V2.5B-M4	-1~2.5bar / 30 in Hg VAC ~ 30psig	
VG20S-V4B-M4	VG20C-V4B-M4	-1~4bar / 30 in Hg VAC ~ 60psig	
VG20S-V6B-M4	VG20C-V6B-M4	-1~6bar / 30 in Hg VAC ~ 86psig	
VG20S-V10B-M4	VG20C-V10B-M4	-1~10bar / 30 in Hg VAC ~ 140psig	
VG20S-V16B-M4	VG20C-V16B-M4	-1~16bar / 30 in Hg VAC ~ 230psig	

(NOTE: To order back mount gauges, please replace "VG" with "VR" in the model no.  
For example:  
VR20S-V16B-M4)

# Kontaktmanometer / Contact Gauges VG20SE Series

## Product Features

- Contact gauge (KI) with inductance contact,
- For monitoring gas supply pressure and shortage,
- For inert, combustible, oxidizing, and corrosive gases and gas mixtures,
- line 0.5m
- With NAMUR sensor
- Set point adjustable over 0-24% of scale
- Tested for use with oxygen

## Typical Applications

Gas panels may be optionally equipped with contact pressure gauges. Contact pressure gauges combine the advantages of in situ readings with the demands of electrical signal transmissions. In combination with signal boxes, this creates visual and acoustic warning signals in the case of pressure drop and the monitoring of line pressure according to adjustable thresholds.



## Technical Data

Dual scale	bar / psi
Connection	1/4" NPT (M)
Size	2"
Accuracy	+/-2.5% of full scale
Body Material	316L
Switching function	Normally closed
Outlet type	NAMUR
Temperature	-25-100°C

## Dimensions (mm)

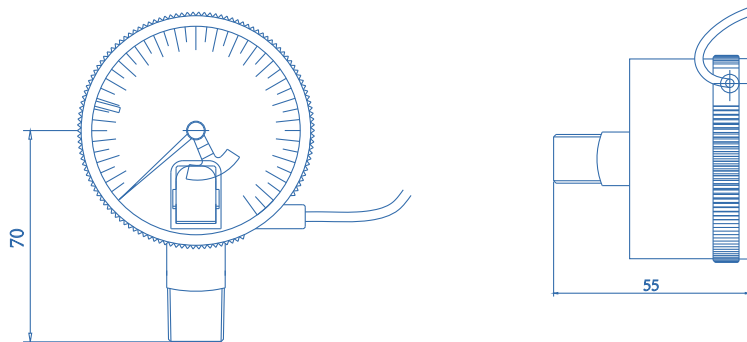

## Ordering Information

### VG 20 SE - 400

G: Bottom inlet Connection

R: Rear inlet Connection

S: 316L

C: Chrome plated brass

400 : 400 bar

250 : 250 bar

60 : 60 bar

25 : 25 bar

# Contact Pressure Gauges / Kontaktmanometer VG25E Series

## Product Features

- Contact pressure gauges with digital signal
- Set point adjustable over 10 - 90% of scale
- Double scale bar / psig
- c/w 2 meters of cable
- Tested for use with oxygen

## Technical Data

Body Material	316L
Working Voltage	180 / 130 VDC
Max. Voltage	200 VDC
Max ON/OFF amperage	0.5 A
Contact power	10 Watt
Contact Current (initial)	150 mΩ
Contact Capacitance	0.2 pF
Insulation resistance	10 <sup>10</sup> Ω
Active Time	0.6 msec (Max)
Release Time	0.2 msec (Max)
Frequency	5.2 kHz
Working Temperature	-40°C ~ 125°C
Nominal diameter	63 mm
Connection	1/4" NPT(M)(bottom)
Length of cable	2 meters
Scale	bar / psig
Window	Laminated safety glass
Switching accuracy	+/- 2.5 % of full scale
Weight	0.375 kg

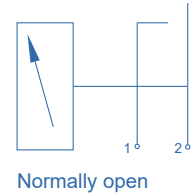
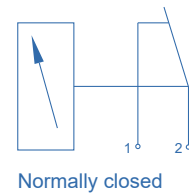

## Dimensions (mm)

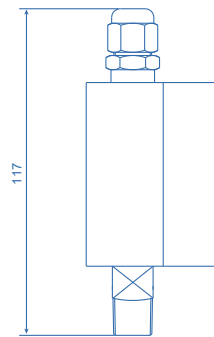
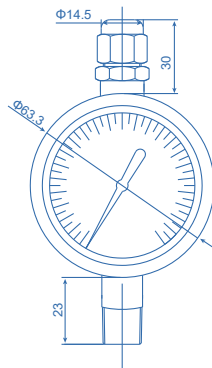

## Ordering Information

**VG25SE - 400 - NO**

### Pressure Range

25: 0~350 psig / 0~25 bar

60: 0~850 psig / 0~60 bar

250: 0~3500 psig / 0~250 bar

400: 0~5800 psig / 0~400 bar

### Status

None: Normally closed

NO : Normally open

# Sampling Cylinders & Single Cylinder Wall Bracket

## Probenahmezylinder & Zubehör / VSC Series

Sampling Cylinders permit the extraction of a sample from a remote process location and provide safe containment for storage and transportation to the laboratory for analysis. Some applications include hydrocarbon sampling in refineries, gas sampling in chromatography and condensate sampling in fossil-fuel and nuclear-power plants. In similar applications, petrochemical facilities and gas processing plants utilize sample cylinders. Pressure surge accumulators or reaction vessels are other common uses for sample cylinders.

### Product Features

- Sampling Cylinders permit the extraction of a sample from a remote process location and provide safe containment for storage and transportation to the laboratory for analysis.
- Working pressures up to 300 bar
- 304 and 316L stainless steel materials resist inter granular corrosion



### Ordering Information



"A" type: Single-ended



"B" type: Double-ended

**VSC - A - SS - 00 - 00 - 150 - E**

Type	Material	Inlets / Outlets	Option	Internal Volume
A : single-ended type B : double-ended type	S4: 304 S: 316L	F4: 1/4"NPT(F) F6: 3/8"NPT(F) F8: 1/2"NPT(F)	E: electropolishing	100: 100 ml 150: 150 ml 250: 250 ml 300: 300 ml 500: 500 ml 1000: 1000 ml 1500: 1500 ml 2000: 2000 ml

\* Other configuration, consult factory.

### Single Cylinder Wall Bracket

- Model No.VWB
- Single Cylinder Wall Bracket Material:ABS
- Straps and cinch style buckles are chosen as primary means of support as they enable the cylinders to be held tight and secure against the brackets.
- Ordering model No.:VWB



### Dimensions (mm)

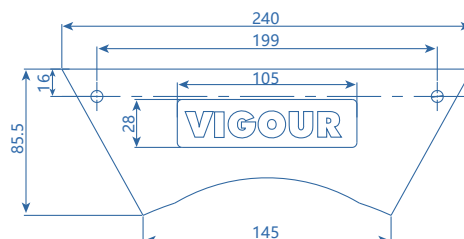
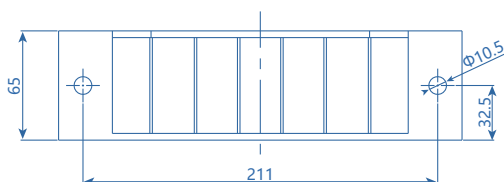

# Pigtails / Flaschenwendeln

## VPP/VPG/VPF/VPS Series

A pigtail connects between a regulator and cylinder with maximum inlet pressure of 400 Bar (VPP series);300 Bar (VPS series);200 Bar(VPF series).  
Tested for use with oxygen.

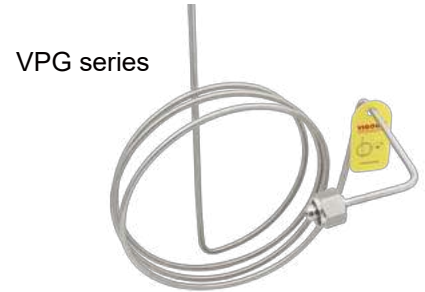
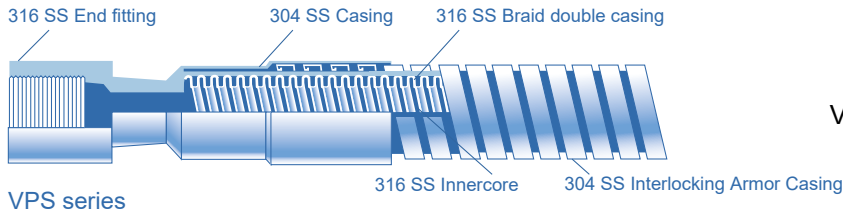

### Ordering Information

**VPF - 1/4 - 10 - F4 - F4**

<p><b>Type</b></p> <p>F: flexible hose core PTFE S: flexible hose core 316 SST</p> <p><b>Orifice</b></p> <p>1/4: 1/4" 1/8: 1/8"</p> <p><b>Length</b></p> <p>5: 500 mm 6: 600 mm 10: 914 mm 20: 2000 mm 30: 3000 mm 50: 50000 mm</p>	<p><b>Outlet Connections</b></p> <p>F4: 1/4"NPT(F) M4: 1/4"NPT(M) 04: 1/4" tube fitting</p> <p><b>Inlet Connections</b></p> <p>F4: 1/4"NPT(F) CGAXXX: CGA cylinder connection BSPX: BSP cylinder connection</p>
---	---

**VPP - 1/4 - 10 - TB - 04**

<p><b>Type</b></p> <p>P: pigtail 316 SST(bending diameter 67mm) G: pigtail 316 SST(bending diameter 240mm)</p> <p><b>Orifice</b></p> <p>1/4: 1/4" tube 6: 6mm tube</p> <p><b>Length</b></p> <p>10: 300 mm</p>	<p><b>Outlet Connections</b></p> <p>F4: 1/4"NPT(F) M4: 1/4"NPT(M) 04: 1/4" tube fitting TB: tube</p> <p><b>Inlet Connections</b></p> <p>TB: tube CGAXXX: CGA cylinder connection BSPX: BSP cylinder connection DINX: BSP cylinder connection</p>
---	--

## Product Feature

- Gas heater
- Suitable for high purity CO<sub>2</sub> and N<sub>2</sub>O gas
- Easy maintenance and replacement of heating elements

## Technical Data

Material	Chrome Plated Brass/316L
Working Voltage	Max.300bar
Thread	1/4NPT(F)
Voltage	36V/110V/220V
Power	190W
Heating	45~60°C



## Product Dimensions

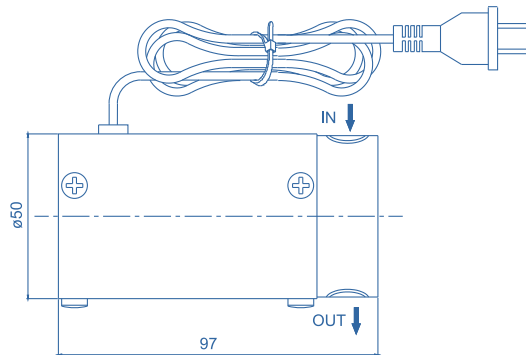

## Ordering Information

**VM -11 S - 220**

### Material

C: Chrome Plated Brass

S: SS316L

### Voltage

36: 36V 190W

110: 110V 190W

220: 220V 190W



# Quick Connectors / Schnellsteckverbinder

## VQC Series

### Product Features

- No twisting, turning, or wrenching necessary
- Single-end shutoff, double-end shutoff models
- Stem insert requires just one O-ring seal, yet improves O-ring containment.
- Locking dog mechanism with large contact area retains stem.
- Push-to-connect coupling enables quick, easy operation.
- Wide variety of options, including keyed quick-connects, are available.
- Heavy-duty sleeve shields open end of body.



### Dimensions

SESO: single-end shutoff  
DESO: double-end shutoff

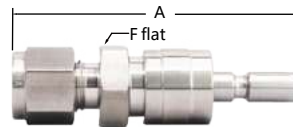

### Stems

#### Tube Fitting



Fitting Size	Ordering Numbers		Flow Coefficient ( $C_v$ )			Dimensions		
	SESO	DESO	SESO	DESO	Full Flow	A		F, in.
Dimensions, in. (mm)								
1/8	S6-VQC4-S-02	S6-VQC4-D-02 <sup>①</sup>	0.08	0.08	0.08	2.32 (58.9)	2.77 (70.4)	5/8
1/4	S6-VQC4-S-04	S6-VQC4-D-04	0.3	0.2	0.4	2.36 (59.9)	2.42 (61.5)	5/8
3/8	S6-VQC6-S-06	S6-VQC6-D-06	1.0	0.5	1.5	2.52 (64.0)	2.64 (67.1)	3/4
1/2	S6-VQC8-S-08	S6-VQC8-D-08	2.4	1.5	3.3	2.96 (75.2)	3.16 (80.3)	15/16
Dimensions, mm (in.)								
6	S6-VQC4-S-6M	S6-VQC4-D-6M	0.3	0.2	0.4	59.9 (2.36)	61.5 (2.42)	5/8
10	S6-VQC6-S-10M	S6-VQC6-D-10M	1.0	0.5	1.5	67.3 (2.65)	70.4 (2.77)	3/4
12	S6-VQC8-S-12M	S6-VQC8-D-12M	2.4	1.5	3.3	75.2 (2.96)	80.3 (3.16)	15/16

Dimensions shown with tube fitting nuts finger-tight.

<sup>①</sup> S6-VQC4-D-02 is a two-piece assembly.

#### Male Pipe Threads



Pipe Size in.	Ordering Numbers		Flow Coefficient ( $C_v$ )			Dimensions, in. (mm)		
	SESO	DESO	SESO	DESO	Full Flow	A		F
Male NPT								
1/8	S6-VQC4-S-M2	S6-VQC4-D-M2	0.3	0.2	0.4	2.07 (52.6)	2.13 (54.1)	5/8
1/4	S6-VQC4-S-M4	S6-VQC4-D-M4	0.3	0.2	0.4	2.22 (56.4)	2.28 (57.9)	5/8
3/8	S6-VQC6-S-M6	S6-VQC6-D-M6	0.8	0.5	1.6	2.35 (59.7)	2.47 (62.7)	3/4
1/2	S6-VQC8-S-M8	S6-VQC8-D-M8	2.0	1.3	3.1	2.84 (72.1)	3.04 (77.2)	15/16

#### Female Pipe Threads



Pipe Size in.	Ordering Numbers		Flow Coefficient ( $C_v$ )			Dimensions, in. (mm)		
	SESO	DESO	SESO	DESO	Full Flow	A		F
Female NPT								
1/8	S6-VQC4-S-F2	S6-VQC4-D-F2	0.3	0.2	0.4	2.01 (51.1)	2.07 (52.6)	5/8
1/4	S6-VQC4-S-F4	S6-VQC4-D-F4	0.3	0.2	0.4	2.26 (57.4)	2.32 (58.9)	3/4
3/8	S6-VQC6-S-F6	S6-VQC6-D-F6	0.8	0.5	1.6	2.35 (59.7)	2.47 (62.7)	7/8
1/2	S6-VQC8-S-F8	S6-VQC8-D-F8	2.0	1.3	3.1	2.82 (71.6)	3.02 (76.7)	15/16

# Schnellsteckverbinder / Quick Connectors

## VQC Series

### Insertion Depth

To calculate overall length in the coupled position, subtract the insertion depth from any overall stem and body combination length.

Series	Depth, in. (mm)	
	SESO	DESO
VQC4	1.09 (27.7)	1.15 (29.2)
VQC6	1.18 (30.0)	1.30 (33.0)
VQC8	1.48 (37.6)	1.68 (42.7)

### Bodies

#### Tube Fitting

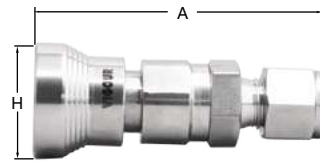

Fitting Size	Ordering Number	Dimensions	
		A	H
Dimensions, in. (mm)			
1/8	S6-VQC4-B-02	2.26 (57.4)	0.91 (23.1)
1/4	S6-VQC4-B-04	2.30 (58.4)	0.91 (23.1)
3/8	S6-VQC6-B-06	2.58 (65.5)	1.03 (26.2)
1/2	S6-VQC8-B-08	3.09 (78.5)	1.21 (30.7)
Dimensions, mm(in.)			
6	S6-VQC4-B-6M	58.4 (2.30)	23.1 (0.91)
10	S6-VQC6-B-10M	68.1 (2.68)	26.2 (1.03)
12	S6-VQC8-B-12M	78.5 (3.09)	30.7 (1.21)

#### Male Pipe Threads



Pipe Size in.	Ordering Number	Dimensions, in. (mm)	
		A	H
Male NPT			
1/8	S6-VQC4-B-M2	2.01 (51.1)	0.91 (23.1)
1/4	S6-VQC4-B-M4	2.16 (54.9)	0.91 (23.1)
	S6-VQC6-B-M4	2.38 (60.5)	1.03 (26.2)
3/8	S6-VQC6-B-M6	2.38 (60.5)	1.03 (26.2)
1/2	S6-VQC8-B-M8	2.97 (75.4)	1.21 (30.7)

#### Female Pipe Threads



Pipe Size in.	Ordering Number	Dimensions, in. (mm)	
		A	H
Female NPT			
1/8	S6-VQC4-B-F2	2.16 (54.9)	0.91 (23.1)
1/4	S6-VQC4-B-F4	2.42 (61.5)	0.91 (23.1)
	S6-VQC6-B-F4	2.54 (64.5)	1.03 (26.2)
3/8	S6-VQC6-B-F6	2.57 (65.3)	1.03 (26.2)
1/2	S6-VQC8-B-F8	3.22 (81.8)	1.21 (30.7)

# Quick Connectors / Schnellsteckverbinder

## VQC Series

### Bulkhead Stems

Tube Fitting

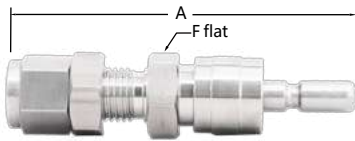

Fitting Size	Basic Ordering Numbers		Dimensions				
			A		F	Max Panel Thickness	Min Panel Hole Dia
	SESO	DESO	SESO	DESO			
Dimensions, in. (mm)							
1/4	S6-VQC4-BS-04	S6-VQC4-BD-04	2.74 (69.6)	2.80 (71.1)	5/8	0.25 (6.4)	15/32 (11.9)
3/8	S6-VQC6-BS-06	S6-VQC6-BD-06	2.92 (74.2)	3.07 (78.0)	3/4	0.27 (6.9)	19/32 (15.1)
1/2	S6-VQC8-BS-08	S6-VQC8-BD-08	3.43 (87.1)	3.63 (92.2)	15/16	0.26 (6.6)	25/32 (19.8)
Dimensions, mm (in.)							
6	S6-VQC4-BS-6M	S6-VQC4-BD-6M	69.6 (2.74)	71.1 (2.80)	16	6.4 (0.25)	11.5 (29/64)
10	S6-VQC6-BS-10M	S6-VQC6-BD-10M	77.7 (3.06)	78.7 (3.10)	22	6.9 (0.27)	16.7 (21/32)
12	S6-VQC8-BS-12M	S6-VQC8-BD-12M	87.1 (3.43)	92.2 (3.63)	24	6.6 (0.26)	19.6 (49/64)

### Bulkhead Bodies

Tube Fitting

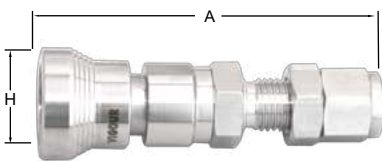

Fitting Size	Ordering Number	Dimensions		Max Panel Thickness	Min Panel Hole Dia
		A	H		
Dimensions, in. (mm)					
1/4	S6-VQC4-BB-04	2.67 (67.8)	0.91 (23.1)	0.25 (6.4)	15/32 (11.9)
3/8	S6-VQC6-BB-06	2.98 (75.7)	1.03 (26.2)	0.27 (6.9)	19/32 (15.1)
1/2	S6-VQC8-BB-08	3.56 (90.4)	1.21 (30.7)	0.26 (6.6)	25/32 (19.8)
Dimensions, mm (in.)					
6	S6-VQC4-BB-6M	67.8 (2.67)	23.1 (0.91)	6.4 (0.25)	11.9 (15/32)
10	S6-VQC6-BB-10M	75.9 (2.99)	26.2 (1.03)	6.9 (0.27)	16.7 (21/32)
12	S6-VQC8-BB-12M	90.4 (3.56)	30.7 (1.21)	6.6 (0.26)	19.6 (49/64)

### Keyed Series

keyed quick-connectors provide a positive mechanical lockout system to prevent accidental intermixing of different lines in multifluid or multipressure systems.

### Product Features

- Keyed quick connectors will not interchange with any other keyed quick connectors
- If an attempt is made to couple unlike keys, the valve system will not open.
- Stems and bodies are color coded and numbered for easy identification.



Key Color	Key Number	QC4		QC6		QC8	
		Body	Stem	Body	Stem	Body	Stem
Black	K1	0.96 (24.4)	0.82 (20.8)	1.13 (28.7)	0.99 (25.1)	1.26 (32.0)	1.10 (27.9)
Orange	K2	0.99 (25.1)	0.85 (21.6)	1.16 (29.5)	1.02 (25.9)	1.29 (32.8)	1.14 (29.0)
Green	K3	1.02 (25.9)	0.88 (22.4)	1.19 (30.2)	1.05 (26.7)	1.32 (33.5)	1.17 (29.7)
Yellow	K4	1.05 (26.7)	0.91 (23.1)	1.22 (31.0)	1.08 (27.4)	1.35 (34.3)	1.20 (30.5)
Blue	K5	1.08 (27.4)	0.94 (23.9)	1.24 (31.5)	1.11 (28.2)	1.38 (35.1)	1.23 (31.2)
White	K6	1.11 (28.2)	0.97 (24.6)	1.28 (32.5)	1.14 (29.0)	1.41 (35.8)	1.26 (32.0)
Purple	K7	1.14 (29.0)	1.00 (25.4)	1.31 (33.3)	1.17 (29.7)	1.44 (36.6)	1.29 (32.8)
Brown	K8	1.17 (29.7)	1.03 (26.2)	1.34 (34.0)	1.20 (30.5)	1.47 (37.3)	1.32 (33.5)

To order, add a key number to a quick-connector ordering number. Example: S6-VQC4-B-F2K1

# Flaschenanschlüsse / Cylinder Connections

## VCC Series

### Product Features

- Cylinder Connections
- Connect to a cylinder valve
- 1/4NPT male /6mm tube fitting /6mm OD tube connection
- Maximum working pressure 200 bar standard
- All connection are supplied with sealing washer



USA - CGA



German - DIN

British - BSP



China - GB



CGA DISS

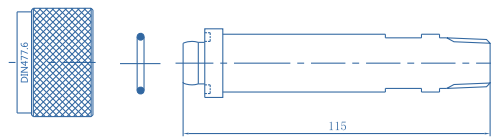

Hand tight nut & nipple  
(Example: VCC-C-HNN-DIN477.6)

### Ordering Information

**VCC - C - N - CGA580 - 6M**

#### Material

- S: 316L
- C: Chrome Plated Brass
- B: Brass

#### Parts

- N: Nut
- NN: Nut & Nipple
- HN: Hand tight nut
- HNN: Hand tight nut & Nipple
- G: Gasket
- P: Plug

#### Inlet Connection

- M4: 1/4"NPT(M)
- 6M: 6mm Tube fitting
- TW6M: 6mm Tube weld
- TW4: 1/4" Tube weld

#### Cylinder Connection

Detailed description of the cylinder connection including the relevant standard and number of the connection

# Cylinder Connections / Flaschenanschlüsse

## DIN 477.1

### Product Features

- DIN 477.1 Cylinder Connections
- Connect to a cylinder valve
- 1/4NPT male connection
- All connection are supplied with sealing washer

Type	Threads	Material	Gases
DIN 477.1	W21.8×1/14" LH	Brass Chrome-plated	N <sub>2</sub> , CH <sub>4</sub> , C <sub>3</sub> H <sub>8</sub> , C <sub>4</sub> H <sub>10</sub> , C <sub>2</sub> H <sub>4</sub> O
DIN 477.3	φ15.3×φ7.5	Brass Chrome-plated	C <sub>2</sub> H <sub>2</sub>
DIN 477.5	W1"×1/8" LH	Brass Chrome-plated	CO
DIN 477.6	W21.8×1/14"	Brass Chrome-plated	Ar, He, CO <sub>2</sub> , NH <sub>3</sub>
DIN 477.7	G5/8"	Brass Chrome-plated	SO <sub>2</sub>
DIN 477.8	W1"×1/8"	Brass Chrome-plated	Cl <sub>2</sub> , COCl <sub>2</sub>
DIN 477.9	G3/4"	Brass Chrome-plated	O <sub>2</sub>
DIN 477.10	W24.32×1/14"	Brass Chrome-plated	N <sub>2</sub>
DIN 477.11	G3/8"	Brass Chrome-plated	N <sub>2</sub> O
DIN 477.13	G5/8"	Brass Chrome-plated	Air
DIN 477.14	M19×1.5LH	Brass Chrome-plated	Test gas(with Oxygen<21%)
DIN 477.1	W21.8×1/14" LH	316L	N <sub>2</sub> , CH <sub>4</sub> , C <sub>3</sub> H <sub>8</sub> , C <sub>4</sub> H <sub>10</sub> , C <sub>2</sub> H <sub>4</sub> O
DIN 477.3	φ15.3×φ7.5	316L	C <sub>2</sub> H <sub>2</sub>
DIN 477.5	W1"×1/8" LH	316L	CO
DIN 477.6	W21.8×1/14"	316L	Ar, He, CO <sub>2</sub> , NH <sub>3</sub>
DIN 477.7	G5/8"	316L	SO <sub>2</sub>
DIN 477.8	W1"×1/8"	316L	Cl <sub>2</sub> , COCl <sub>2</sub>
DIN 477.9	G3/4"	316L	O <sub>2</sub>
DIN 477.10	W24.32×1/14"	316L	N <sub>2</sub>
DIN 477.11	G3/8"	316L	N <sub>2</sub> O
DIN 477.13	G5/8"	316L	Air
DIN 477.14	M19×1.5LH	316L	Test gas(with Oxygen<21%)

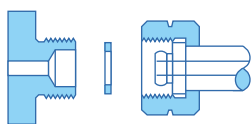

DIN 1 21.8 mmx1/14" -LH EXT.  
Flat Seal with Gasket

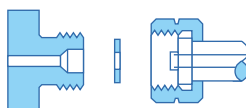

DIN 5 1" -LH EXT.  
Flat Seal with Gasket

DIN 8 1" -RH EXT.  
Flat Seal with Gasket

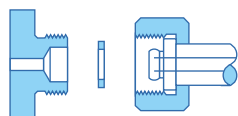

DIN 10 24.32mmx1/14" -RH EXT.  
Flat Seal with Gasket

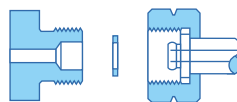

DIN 14 M 19x1.5mm -LH EXT.  
Flat Seal with Gasket

### Product Features

- DIN 477.1 Cylinder Connections
- Connect to a cylinder valve
- 6mm tube fitting connection
- All connection are supplied with sealing washer

Type	Threads	Material	Gases
DIN 477.1	W21.8×1/14" LH	316L	N <sub>2</sub> , CH <sub>4</sub> , C <sub>3</sub> H <sub>8</sub> , C <sub>4</sub> H <sub>10</sub> , C <sub>2</sub> H <sub>4</sub> O
DIN 477.5	W1"×1/8" LH	316L	CO
DIN 477.6	W21.8×1/14"	316L	Ar, He, CO <sub>2</sub> , NH <sub>3</sub>
DIN 477.7	G5/8"	316L	SO <sub>2</sub>
DIN 477.8	W1"×1/8"	316L	Cl <sub>2</sub> , COCl <sub>2</sub>
DIN 477.9	G3/4"	316L	O <sub>2</sub>
DIN 477.10	W24.32×1/14"	316L	N <sub>2</sub>
DIN 477.11	G3/8"	316L	N <sub>2</sub> O
DIN 477.13	G5/8"	316L	Air
DIN 477.14	M19×1.5LH	316L	Test gas(with Oxygen<21%)

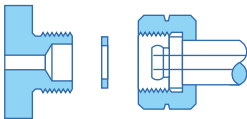

DIN 1 21.8 mmx1/14" -LH EXT.  
Flat Seal with Gasket

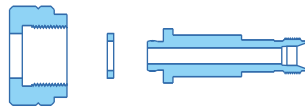

DIN 5 1" -LH EXT.  
Flat Seal with Gasket

DIN 8 1" -RH EXT.  
Flat Seal with Gasket

### Product Features

- DIN 477.1 Cylinder Connections
- Connect to a cylinder valve
- 6mm OD tube connection
- All connection are supplied with sealing washer

Type	Threads	Material	Gases
DIN 477.1	W21.8×1/14" LH	316L	N <sub>2</sub> , CH <sub>4</sub> , C <sub>3</sub> H <sub>8</sub> , C <sub>4</sub> H <sub>10</sub> , C <sub>2</sub> H <sub>4</sub> O
DIN 477.5	W1"×1/8" LH	316L	CO
DIN 477.6	W21.8×1/14"	316L	Ar, He, CO <sub>2</sub> , NH <sub>3</sub>
DIN 477.7	G5/8"	316L	SO <sub>2</sub>
DIN 477.8	W1"×1/8"	316L	Cl <sub>2</sub> , COCl <sub>2</sub>
DIN 477.9	G3/4"	316L	O <sub>2</sub>
DIN 477.10	W24.32×1/14"	316L	N <sub>2</sub>
DIN 477.11	G3/8"	316L	N <sub>2</sub> O
DIN 477.13	G5/8"	316L	Air
DIN 477.14	M19×1.5LH	316L	Test gas(with Oxygen<21%)

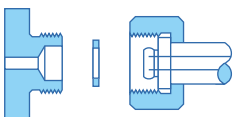

DIN 10 24.32mmx1/14" -RH EXT.  
Flat Seal with Gasket

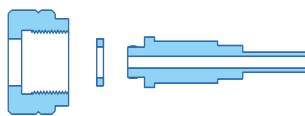

DIN 14 M 19x1.5mm -LH EXT.  
Flat Seal with Gasket

# Cylinder Connections / Flaschenanschlüsse

## DIN 477.1 / DIN 477.5

### Product Features

- DIN 477.1 Cylinder Connections
- Hand-tight type
- Connect to a cylinder valve
- 1/4NPT male connection
- All connection are supplied with o-ring

Type	Threads	Material	Gases
DIN 477.1	W21.8×1/14" LH	316L	N <sub>2</sub> , CH <sub>4</sub> , C <sub>3</sub> H <sub>8</sub> , C <sub>4</sub> H <sub>10</sub> , C <sub>2</sub> H <sub>4</sub> O
DIN 477.6	W21.8×1/14"	316L	Ar, He, CO <sub>2</sub> , NH <sub>3</sub>
DIN 477.9	G3/4"	316L	O <sub>2</sub>
DIN 477.10	W24.32×1/14"	316L	N <sub>2</sub>
DIN 477.14	M19×1.5LH	316L	Test gas(with Oxygen<21%)

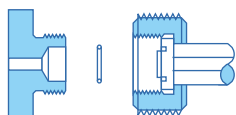

DIN 10 24.32mmx1/14" -RH EXT.  
Flat Seal with Gasket

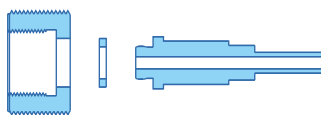

DIN 14 M 19x1.5mm -LH EXT.  
Flat Seal with Gasket

### Product Features

- DIN 477.5 Cylinder Connections
- Connect to a cylinder valve
- 1/4NPT male connection
- All connection are supplied with o-ring

Type	Threads	Material	Gases
DIN 477.54	W30×2	316L	not flammable,non poisonous and not oxidizing gases and gas mixtures
DIN 477.55	W30×2	316L	not flammable,poisonous and oxidizing gases and gas mixtures
DIN 477.56	W30×2	316L	pressurized air
DIN 477.57	W30×2	316L	flammable,not poisonous gases and gas mixtures
DIN 477.58	W30×2LH	316L	flammable,poisonous and oxidizing or not oxidizing gases and gas mixtures
DIN 477.59	W30×2LH	316L	Oxygen and oxidizing,non poisonous,not oxidizing gases and gas mixtures

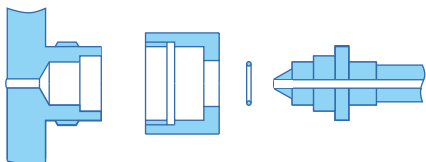

### Gaskets DIN477.1



Threads	Material
DIN477.1 DIN477.6 DIN477.7	Teflon® (PCTFE)
DIN477.5 DIN477.8	Teflon® (PCTFE)
DIN477.9 DIN477.10 DIN477.13	Teflon® (PCTFE)

### O-ring(DIN477.5)



Type	Material
$\varnothing 7.66 \times \varnothing 1.78$	VITON



### Product Features

- CGA Cylinder Connections
- Connect to a cylinder valve
- 1/4NPT male connection(CGA180 1/8NPT)

Type	Threads	Material	Gases
CGA160	1/8" - 27 NGT-RH-INT	Brass Chrome-plated	Phosgene
CGA180	.625"-18UNF RH EXT	Brass Chrome-plated	Small cylinder - Non corrosive gases
CGA300	.825"-14 NGO RH EXT	Brass Chrome-plated	C <sub>2</sub> H <sub>2</sub>
CGA320	.825"-14 NGO RH EXT	Brass Chrome-plated	CO <sub>2</sub>
CGA326	.825"-14 NGO RH EXT	Brass Chrome-plated	N <sub>2</sub> O
CGA346	.825"-14 NGO RH EXT	Brass Chrome-plated	Air
CGA350	.825"-14 NGO LH EXT	Brass Chrome-plated	H <sub>2</sub> , CH <sub>4</sub> , CO
CGA510	.885"-14 NGO LH INT	Brass Chrome-plated	C <sub>2</sub> H <sub>2</sub> , C <sub>3</sub> H <sub>8</sub> , C <sub>4</sub> H <sub>10</sub> , C <sub>2</sub> H <sub>4</sub> O
CGA540	.903"-14 NGO RH EXT	Brass Chrome-plated	O <sub>2</sub>
CGA580	.965"-14 NGO RH INT	Brass Chrome-plated	N <sub>2</sub> , Ar, He
CGA590	.965"-14 NGO LH INT	Brass Chrome-plated	Air, He
CGA660	1.03"-14 RH EXT	Brass Chrome-plated	CO <sub>2</sub> , Cl <sub>2</sub>
CGA180	.625"-18UNF RH EXT	316L	Small cylinder - Non corrosive gases
CGA300	.825"-14 NGO RH EXT	316L	C <sub>2</sub> H <sub>2</sub>
CGA320	.825"-14 NGO RH EXT	316L	CO <sub>2</sub>
CGA326	.825"-14 NGO RH EXT	316L	N <sub>2</sub> O
CGA346	.825"-14 NGO RH EXT	316L	Air
CGA350	.825"-14 NGO LH EXT	316L	H <sub>2</sub> , CH <sub>4</sub> , CO
CGA510	.885"-14 NGO LH INT	316L	C <sub>2</sub> H <sub>2</sub> , C <sub>3</sub> H <sub>8</sub> , C <sub>4</sub> H <sub>10</sub> , C <sub>2</sub> H <sub>4</sub> O
CGA540	.903"-14 NGO RH EXT	316L	O <sub>2</sub>
CGA580	.965"-14 NGO RH INT	316L	N <sub>2</sub> , Ar, He
CGA590	.965"-14 NGO LH INT	316L	Air, He
CGA660	1.03"-14 RH EXT	316L	CO <sub>2</sub> , Cl <sub>2</sub>

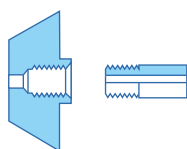

CGA 160 1/8" -27 NGT RH INT.

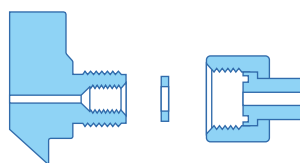

CGA 180 0.625" -18 UNF 2A RH EXT. with Gasket

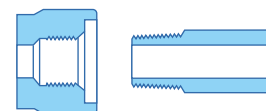

CGA 240 3/8" -18 NGT -RH INT.

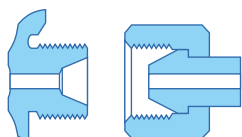

CGA 300 0.825" -14 NGO RH EX.

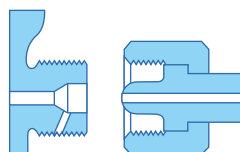

CGA 326 0.825" -14 RH EXT.

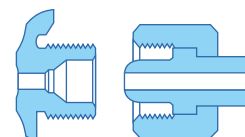

CGA 346 0.825" -14 NGO.

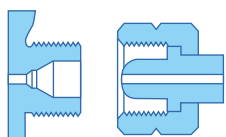

CGA 350 0.825" -14 LH EXT.

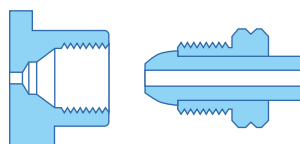

CGA 510 0.885" -14 LH INT.

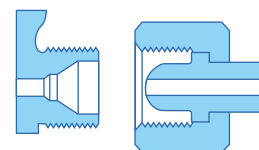

CGA 540 0.903" -14 RH .

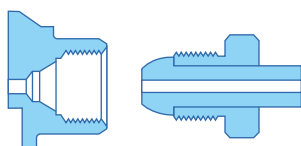

CGA 580 0.965" -14 RH INT.

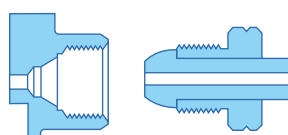

CGA 590 0.965" -14 NGO LH INT.

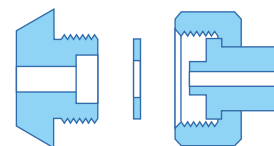

CGA 660 1.03" -14 with Gasket

## Product Features

- BSP Cylinder Connections
- Connect to a cylinder valve
- 1/4NPT male connection
- All connection are supplied with sealing washer (not required for BS3 or BS4)

Type	Threads	Material	Gases
BS341-2	G5/8"LH	Brass Chrome-plated	H <sub>2</sub> , CH <sub>4</sub> , C <sub>2</sub> H <sub>2</sub>
BS341-3	G5/8'	Brass Chrome-plated	Air, N <sub>2</sub> , Ar, He, O <sub>2</sub>
BS341-4	G5/8'LH	Brass Chrome-plated	CO, C <sub>3</sub> H <sub>8</sub> , C <sub>4</sub> H <sub>10</sub>
BS341-6	G5/8"A	Brass Chrome-plated	Cl <sub>2</sub>
BS341-7	G5/8"ALH	Brass Chrome-plated	C <sub>2</sub> H <sub>4</sub> O
BS341-8	0.860"×14TPI	Brass Chrome-plated	CO <sub>2</sub>
BS341-10	G1/2"A	Brass Chrome-plated	NH <sub>3</sub> , SO <sub>2</sub>
BS341-13	11/16"×20TPI	Brass Chrome-plated	N <sub>2</sub> O
BS341-14	G3/8"	Brass Chrome-plated	BCl <sub>3</sub> , BF <sub>3</sub> , CCl <sub>2</sub> O, Cl
BS341-15	G3/8"LH	Brass Chrome-plated	COS, H <sub>2</sub> S
BS341-2	G5/8"LH	316L	H <sub>2</sub> , CH <sub>4</sub> , C <sub>2</sub> H <sub>2</sub>
BS341-3	G5/8'	316L	Air, N <sub>2</sub> , Ar, He, O <sub>2</sub>
BS341-4	G5/8'	316L	CO, C <sub>3</sub> H <sub>8</sub> , C <sub>4</sub> H <sub>10</sub>
BS341-6	G5/8"A	316L	Cl <sub>2</sub>
BS341-7	G5/8"ALH	316L	C <sub>2</sub> H <sub>4</sub> O
BS341-8	0.860"×14TPI	316L	CO <sub>2</sub>
BS341-10	G1/2"A	316L	NH <sub>3</sub> , SO <sub>2</sub>
BS341-13	11/16"×20TPI	316L	N <sub>2</sub> O
BS341-14	G3/8"	316L	BCl <sub>3</sub> , BF <sub>3</sub> , CCl <sub>2</sub> O, Cl
BS341-15	G3/8"LH	316L	COS, H <sub>2</sub> S

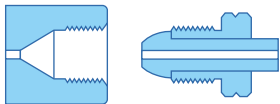

BS No 2 5/8" BSP LH INT.  
BS No 4 5/8" BSP LH INT.

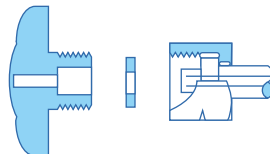

BS No 6 5/8" BSP RH EXT.  
Flat Seal with Gasket  
BS No 8 0.86 BSW RH EXT.  
Flat Seal with Gasket

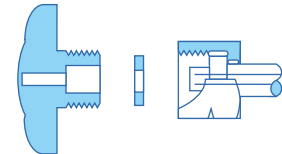

BS No 14 3/8" BSP RH EXT.  
Flat Seal with Gasket  
BS No 15 3/8" BSP LH EXT.  
Flat Seal with Gasket

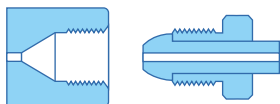

BS No 3 5/8" BSP RH INT.

# Cylinder Connections / Flaschenanschlüsse

## GB

### Product Features

- GB Cylinder Connections
- Connect to a cylinder valve
- 1/4NPT male connection

Type	Material	Gases
G5/8(F)	Brass Chrome-plated	Air, N <sub>2</sub> , Ar, He, O <sub>2</sub> , CO <sub>2</sub> , N <sub>2</sub> O, SO <sub>2</sub>
W21.8×1/14"LH(F)	Brass Chrome-plated	H <sub>2</sub> , CH <sub>4</sub> , CO, C <sub>4</sub> H <sub>10</sub> , C <sub>2</sub> H <sub>4</sub> O, COCl <sub>2</sub>
G1/2(F)	Brass Chrome-plated	NH <sub>3</sub>
M22×1.5LH(M)	Brass Chrome-plated	C <sub>3</sub> H <sub>8</sub>
W21.8×1/14"RH(F)	Brass Chrome-plated	Mix Gas
G5/8(F)	316L	Air, N <sub>2</sub> , Ar, He, O <sub>2</sub> , CO <sub>2</sub> , N <sub>2</sub> O, SO <sub>2</sub>
W21.8×1/14"LH(F)	316L	H <sub>2</sub> , CH <sub>4</sub> , CO, C <sub>4</sub> H <sub>10</sub> , C <sub>2</sub> H <sub>4</sub> O, COCl <sub>2</sub>
G1/2(F)	316L	NH <sub>3</sub>
M22×1.5LH(M)	316L	C <sub>3</sub> H <sub>8</sub>
W21.8×1/14"RH(F)	316L	Mix Gas

### Product Features

- GB Cylinder Connections
- Connect to a cylinder valve
- 1/4" tube fitting connection

Type	Material	Gases
G5/8(F)	316L	Air, N <sub>2</sub> , Ar, He, O <sub>2</sub> , CO <sub>2</sub> , N <sub>2</sub> O, SO <sub>2</sub>
W21.8×1/14"LH(F)	316L	H <sub>2</sub> , CH <sub>4</sub> , CO, C <sub>4</sub> H <sub>10</sub> , C <sub>2</sub> H <sub>4</sub> O, COCl <sub>2</sub>
G1/2(F)	316L	NH <sub>3</sub>
M22×1.5LH(M)	316L	C <sub>3</sub> H <sub>8</sub>
W21.8×1/14"RH(F)	316L	Mix Gas

### Product Features

- GB Cylinder Connections
- Connect to a cylinder valve
- 6mm tube fitting connection

Type	Material	Gases
G5/8(F)	316L	Air, N <sub>2</sub> , Ar, He, O <sub>2</sub> , CO <sub>2</sub> , N <sub>2</sub> O, SO <sub>2</sub>
W21.8×1/14"LH(F)	316L	H <sub>2</sub> , CH <sub>4</sub> , CO, C <sub>4</sub> H <sub>10</sub> , C <sub>2</sub> H <sub>4</sub> O, COCl <sub>2</sub>
G1/2(F)	316L	NH <sub>3</sub>
M22×1.5LH(M)	316L	C <sub>3</sub> H <sub>8</sub>
W21.8×1/14"RH(F)	316L	Mix Gas

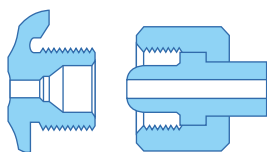

G5/8

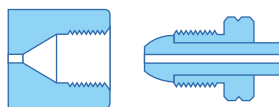

M22 × 1.5LH

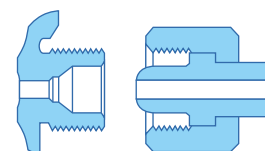

W21.8RH

### Product Features

- JIS Cylinder Connections
- Connect to a cylinder valve
- 1/4NPT male connection
- All connection are supplied with sealing washer

Type	Material	Gas services
W22RH	Brass Chrome-plated	Ar, N <sub>2</sub> , O <sub>2</sub> , Xe, Ne, CO <sub>2</sub> , Kr, CF <sub>4</sub>
W21LH	Brass Chrome-plated	He
W22LH	Brass Chrome-plated	H <sub>2</sub> , CO, CH <sub>4</sub> , C <sub>2</sub> H <sub>5</sub> , C <sub>2</sub> H <sub>4</sub> , SiH <sub>4</sub>
W23RH	Brass Chrome-plated	O <sub>2</sub>
W22.5LH	Brass Chrome-plated	LPG
W26RH	Brass Chrome-plated	Cl <sub>2</sub> , HCl, Kr, CCl <sub>2</sub> F <sub>2</sub> , CHClF <sub>2</sub>
W27RH	Brass Chrome-plated	N <sub>2</sub> O
York	Brass Chrome-plated	C <sub>2</sub> H <sub>2</sub>
W22RH	316L	Ar, N <sub>2</sub> , O <sub>2</sub> , Xe, Ne, CO <sub>2</sub> , Kr, CF <sub>4</sub>
W21LH	316L	He
W22LH	316L	H <sub>2</sub> , CO, CH <sub>4</sub> , C <sub>2</sub> H <sub>5</sub> , C <sub>2</sub> H <sub>4</sub> , SiH <sub>4</sub>
W23RH	316L	O <sub>2</sub>
W22.5LH	316L	LPG
W26RH	316L	Cl <sub>2</sub> , HCl, Kr, CCl <sub>2</sub> F <sub>2</sub> , CHClF <sub>2</sub>
W27RH	316L	N <sub>2</sub> O
York	316L	C <sub>2</sub> H <sub>2</sub>

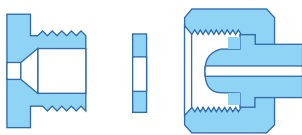

W22RH

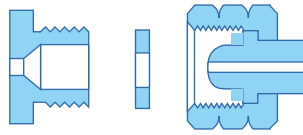

W21LH

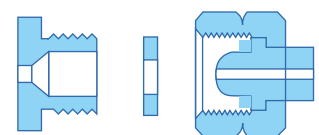

W22LH

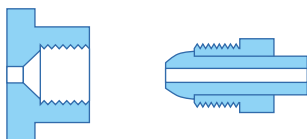

W23RH

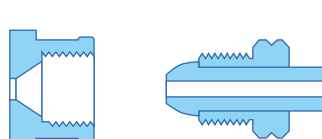

W22.5LH

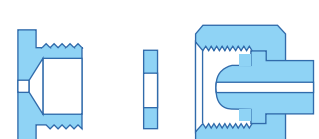

W26RH

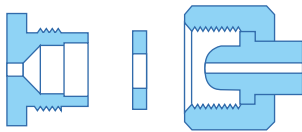

W27RH

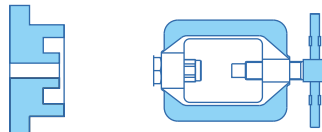

York

# Cylinder Connections / Flaschenanschlüsse

## Adaptors

Model NO.	Threads	Material
VPN-M4	1/4"NPT Plug	SS 316L
S-VAD-M4-H8M	1/4 NPT(M) × 8mm Hose	SST
S-VAD-M4-H6M	1/4 NPT(M) × 6mm Hose	SST
S-VAD-M4-H10M	1/4 NPT(M) × 10mm Hose	SST
B-VAD-M4-M4	1/4NPT(M)×1/4NPT(M)	Brass
C-VAD-M4-M4	1/4NPT(M)×1/4NPT(M)	Chrome-plated Brass
S-VAD-M4-M4	1/4NPT(M)×1/4NPT(M)	316L
B-VAD-M4-M2	1/4NPT(M)×1/8NPT(M)	Brass
C-VAD-M4-M2	1/4NPT(M)×1/8NPT(M)	Chrome-plated Brass
S-VAD-M4-M2	1/4NPT(M)×1/8NPT(M)	316L
B-VAD-F4-F4	1/4NPT(F)×1/4NPT(F)	Brass
C-VAD-F4-F4	1/4NPT(F)×1/4NPT(F)	Chrome-plated Brass
S-VAD-F4-F4	1/4NPT(F)×1/4NPT(F)	316L
B-VAD-F4-F2	1/4NPT(F)×1/8NPT(F)	Brass
C-VAD-F4-F2	1/4NPT(F)×1/8NPT(F)	Chrome-plated Brass
S-VAD-F4-F2	1/4NPT(F)×1/8NPT(F)	316L
B-VAD-F4-F8	1/4NPT(F)×1/2NPT(F)	Brass
C-VAD-F4-F8	1/4NPT(F)×1/2NPT(F)	Chrome-plated Brass
S-VAD-F4-F8	1/4NPT(F)×1/2NPT(F)	316L
B-VAD-M4-F4	1/4NPT(M)×1/4NPT(F)	Brass
C-VAD-M4-F4	1/4NPT(M)×1/4NPT(F)	Chrome-plated Brass
S-VAD-M4-F4	1/4NPT(M)×1/4NPT(F)	316L
B-VAD-M2-F4	1/8NPT(M)×1/4NPT(F)	Brass
C-VAD-M2-F4	1/8NPT(M)×1/4NPT(F)	Chrome-plated Brass
S-VAD-M2-F4	1/8NPT(M)×1/4NPT(F)	316L
B-VAD-M4-F8	1/4NPT(M)×1/2NPT(F)	Brass
C-VAD-M4-F8	1/4NPT(M)×1/2NPT(F)	Chrome-plated Brass
S-VAD-M4-F8	1/4NPT(M)×1/2NPT(F)	316L
B-VAD-M8-F4	1/2NPT(M)×1/4NPT(F)	Brass
C-VAD-M8-F4	1/2NPT(M)×1/4NPT(F)	Chrome-plated Brass
S-VAD-M8-F4	1/2NPT(M)×1/4NPT(F)	316L
B-VAD-M6-F4	3/8NPT(M)×1/4NPT(F)	Brass
C-VAD-M6-F4	3/8NPT(M)×1/4NPT(F)	Chrome-plated Brass
S-VAD-M6-F4	3/8NPT(M)×1/4NPT(F)	316L

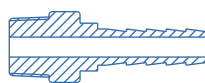

VAD-M4-H8M

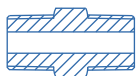

VAD-M4-M4

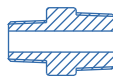

VAD-M4-M2

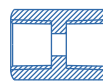

VAD-F4-F4



VAD-F4-F2



VAD-F8-F4

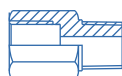

VAD-M4-F4



VAD-M4-F8



VAD-M4-F8

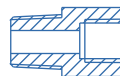

VAD-M8-F4

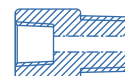

VAD-M6-F4

## MALE CONNECTOR

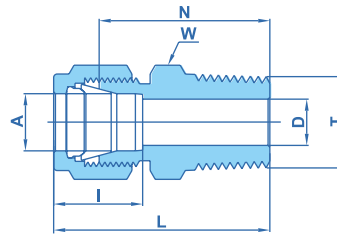

TUBE (METRIC) MALE NPT THREAD							
Ordering Information	A	T	D	W	N	L	I
	Tube O.D.	(NPT)		Hex. Flat			
	mm	inch	mm	mm	mm	mm	mm
SS- VMC - 3M - M2	3	1/8	2.4	12	23.9	30.5	12.9
SS- VMC - 3M - M4	3	1/4	2.4	14	29.0	35.6	12.9
SS- VMC - 4M - M2	4	1/8	2.4	12	24.6	31.2	13.7
SS- VMC - 4M - M4	4	1/4	2.4	14	29.7	36.3	13.7
SS- VMC - 6M - M2	6	1/8	4.8	14	25.4	32.8	15.3
SS- VMC - 6M - M4	6	1/4	4.8	14	30.5	37.9	15.3
SS- VMC - 6M - M6	6	3/8	4.8	18	31.0	38.4	15.3
SS- VMC - 6M - M8	6	1/2	4.8	22	37.3	44.7	15.3
SS- VMC - 8M - M2	8	1/8	4.8	15	26.7	34.2	16.2
SS- VMC - 8M - M4	8	1/4	6.4	15	31.2	38.7	16.2
SS- VMC - 8M - M6	8	3/8	6.4	18	31.8	39.3	16.2
SS- VMC - 8M - M8	8	1/2	6.4	22	38.1	45.6	16.2
SS- VMC - 10M - M2	10	1/8	4.8	18	28.7	36.3	17.2
SS- VMC - 10M - M4	10	1/4	7.9	18	33.3	40.9	17.2
SS- VMC - 10M - M6	10	3/8	7.9	18	33.3	40.9	17.2
SS- VMC - 10M - M8	10	1/2	7.9	22	38.9	46.5	17.2
SS- VMC - 10M - M12	10	3/4	7.9	27	40.4	48.0	17.2
SS- VMC - 12M - M2	12	1/8	4.8	22	28.7	38.8	22.8
SS- VMC - 12M - M4	12	1/4	7.1	22	33.3	43.4	22.8
SS- VMC - 12M - M6	12	3/8	9.5	22	33.3	43.4	22.8
SS- VMC - 12M - M8	12	1/2	9.5	22	38.9	49.0	22.8
SS- VMC - 12M - M12	12	3/4	9.5	27	40.4	50.5	22.8
SS- VMC - 14M - M4	14	1/4	7.1	24	34.0	44.1	24.4
SS- VMC - 14M - M6	14	3/8	9.5	24	34.0	44.1	24.4
SS- VMC - 14M - M8	14	1/2	11.1	24	38.9	49.0	24.4
SS- VMC - 15M - M8	15	1/2	11.9	24	38.9	49.0	24.4
SS- VMC - 16M - M6	16	3/8	9.5	24	34.0	44.1	24.4
SS- VMC - 16M - M8	16	1/2	11.9	24	38.9	49.0	24.4
SS- VMC - 16M - M12	16	3/4	12.7	27	40.4	50.5	24.4
SS- VMC - 18M - M8	18	1/2	11.9	27	40.4	50.5	24.4
SS- VMC - 18M - M12	18	3/4	15.1	27	40.4	50.5	24.4
SS- VMC - 20M - M8	20	1/2	11.9	30	42.2	52.3	26.0
SS- VMC - 20M - M12	20	3/4	15.9	30	42.2	52.3	26.0
SS- VMC - 22M - M12	22	3/4	15.9	30	42.2	52.3	26.0
SS- VMC - 22M - M16	22	1	18.3	35	47.0	57.1	26.0
SS- VMC - 25M - M8	25	1/2	11.9	35	45.2	57.5	31.3
SS- VMC - 25M - M12	25	3/4	15.9	35	45.2	57.5	31.3
SS- VMC - 25M - M16	25	1	21.8	35	50.0	62.3	31.3

# Tube Fittings / Zweiklemmring Verschraubung

## VMC Series

### MALE CONNECTOR

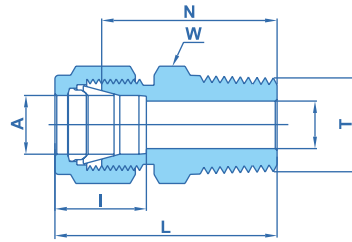

TUBE (INCH) MALE NPT THREAD												
Ordering Information	A Tube O.D.		T (NPT)	D		W Hex. Flat	N		L		I	
	inch	mm		inch	mm		inch	mm	inch	mm	inch	mm
SS- VMC - 02 - M2	1/8	3.17	1/8	.09	2.28	7/16	.94	23.90	1.20	30.48	.50	12.7
SS- VMC - 02 - M4	1/8	3.17	1/4	.09	2.28	9/16	1.14	28.95	1.40	35.56	.50	12.7
SS- VMC - 02 - M6	1/8	3.17	3/8	.09	2.28	11/16	1.15	29.21	1.41	35.81	.50	12.7
SS- VMC - 02 - M8	1/8	3.17	1/2	.09	2.28	7/8	1.40	35.56	1.66	42.16	.50	12.7
SS- VMC - 03 - M2	3/16	4.76	1/8	.12	3.04	7/16	.97	24.63	1.23	31.24	.54	13.7
SS- VMC - 03 - M4	3/16	4.76	1/4	.12	3.04	9/16	1.17	29.72	1.43	36.32	.54	13.7
SS- VMC - 04 - M2	1/4	6.35	1/8	.19	4.82	1/2	1.00	25.40	1.29	32.76	.60	15.2
SS- VMC - 04 - M4	1/4	6.35	1/4	.19	4.82	9/16	1.20	30.50	1.49	37.85	.60	15.2
SS- VMC - 04 - M6	1/4	6.35	3/8	.19	4.82	11/16	1.22	30.98	1.51	38.35	.60	15.2
SS- VMC - 04 - M8	1/4	6.35	1/2	.19	4.82	7/8	1.47	37.34	1.76	44.70	.60	15.2
SS- VMC - 04 - M12	1/4	6.35	3/4	.19	4.82	1 1/16	1.53	38.86	1.82	46.22	.60	15.2
SS- VMC - 05 - M2	5/16	7.93	1/8	.19	4.82	9/16	1.05	26.67	1.34	34.03	.64	16.2
SS- VMC - 05 - M4	5/16	7.93	1/4	.25	6.35	9/16	1.23	31.24	1.52	38.60	.64	16.2
SS- VMC - 05 - M6	5/16	7.93	3/8	.25	6.35	11/16	1.25	31.75	1.54	39.11	.64	16.2
SS- VMC - 06 - M2	3/8	9.52	1/8	.19	4.82	5/8	1.10	27.90	1.39	35.30	.66	16.8
SS- VMC - 06 - M4	3/8	9.52	1/4	.28	7.11	5/8	1.28	32.51	1.57	39.87	.66	16.8
SS- VMC - 06 - M6	3/8	9.52	3/8	.28	7.11	11/16	1.28	32.51	1.57	39.87	.66	16.8
SS- VMC - 06 - M8	3/8	9.52	1/2	.28	7.11	7/8	1.53	38.90	1.82	46.23	.66	16.8
SS- VMC - 06 - M12	3/8	9.52	3/4	.28	7.11	1 1/16	1.59	40.38	1.88	47.75	.66	16.8
SS- VMC - 06 - M16	3/8	9.52	1	.28	7.11	1 3/8	1.85	46.99	2.14	54.35	.66	16.8
SS- VMC - 08 - M2	1/2	12.70	1/8	.19	4.82	13/16	1.13	28.70	1.53	38.86	.90	22.9
SS- VMC - 08 - M4	1/2	12.70	1/4	.28	7.11	13/16	1.31	33.27	1.71	43.43	.90	22.9
SS- VMC - 08 - M6	1/2	12.70	3/8	.38	9.65	13/16	1.31	33.27	1.71	43.43	.90	22.9
SS- VMC - 08 - M8	1/2	12.70	1/2	.41	10.41	7/8	1.53	38.90	1.93	49.02	.90	22.9
SS- VMC - 08 - M12	1/2	12.70	3/4	.41	10.41	1 1/16	1.59	40.38	1.99	50.54	.90	22.9
SS- VMC - 08 - M16	1/2	12.70	1	.41	10.41	1 3/8	1.85	47.00	2.25	57.15	.90	22.9
SS- VMC - 10 - M4	5/8	15.87	1/4	.28	7.11	15/16	1.34	34.03	1.74	44.19	.96	24.4
SS- VMC - 10 - M6	5/8	15.87	3/8	.38	9.65	15/16	1.34	34.03	1.74	44.19	.96	24.4
SS- VMC - 10 - M8	5/8	15.87	1/2	.47	11.90	15/16	1.53	38.86	1.93	49.02	.96	24.4
SS- VMC - 10 - M12	5/8	15.87	3/4	.50	12.70	1 1/16	1.59	40.38	1.99	50.54	.96	24.4
SS- VMC - 12 - M6	3/4	19.05	3/8	.38	9.50	1 1/16	1.38	35.05	1.78	45.21	.96	24.4
SS- VMC - 12 - M8	3/4	19.05	1/2	.47	11.90	1 1/16	1.59	40.38	1.99	50.54	.96	24.4
SS- VMC - 12 - M12	3/4	19.05	3/4	.62	15.75	1 1/16	1.59	40.38	1.99	50.54	.96	24.4
SS- VMC - 12 - M16	3/4	19.05	1	.62	15.75	1 3/8	1.85	47.00	2.25	57.15	.96	24.4

## MALE ELBOW

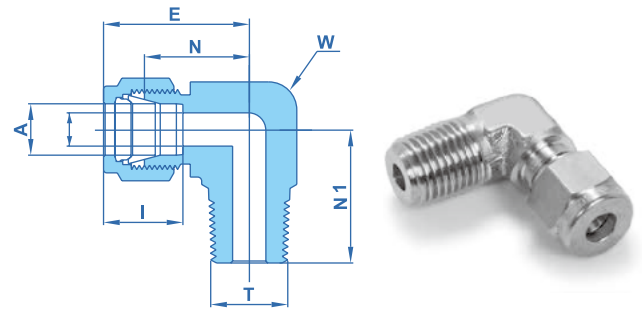

TUBE (METRIC) MALE NPT THREAD

Ordering Information	A	T	D	W		N	E	N1	I
	Tube O.D.	(NPT)		Wrench Flat					
	mm	inch	mm	inch	mm	mm	mm	mm	mm
SS- VME - 3M - M2	3	1/8	2.4	7/16	11.1	17.0	23.6	17.8	12.9
SS- VME - 3M - M4	3	1/4	2.4	1/2	12.7	18.0	24.6	23.4	12.9
SS- VME - 4M - M2	4	1/8	2.4	1/2	12.7	18.8	25.4	18.8	13.7
SS- VME - 4M - M4	4	1/4	2.4	1/2	12.7	18.8	25.4	23.4	13.7
SS- VME - 6M - M2	6	1/8	4.8	1/2	12.7	19.6	27.0	18.8	15.3
SS- VME - 6M - M4	6	1/4	4.8	1/2	12.7	19.6	27.0	23.4	15.3
SS- VME - 6M - M6	6	3/8	4.8	11/16	17.5	22.4	29.8	26.2	15.3
SS- VME - 6M - M8	6	1/2	4.8	13/16	20.6	24.4	31.8	33.0	15.3
SS- VME - 8M - M2	8	1/8	4.8	9/16	14.3	21.3	28.8	19.8	16.2
SS- VME - 8M - M4	8	1/4	6.4	9/16	14.3	21.3	28.8	24.4	16.2
SS- VME - 8M - M6	8	3/8	6.4	11/16	17.5	23.1	30.6	26.2	16.2
SS- VME - 8M - M8	8	1/2	6.4	13/16	20.6	25.1	32.6	33.0	16.2
SS- VME - 10M - M2	10	1/8	4.8	11/16	17.5	23.9	31.5	21.6	17.2
SS- VME - 10M - M4	10	1/4	7.1	11/16	17.5	23.9	31.5	26.2	17.2
SS- VME - 10M - M6	10	3/8	7.9	11/16	17.5	23.9	31.5	26.2	17.2
SS- VME - 10M - M8	10	1/2	7.9	13/16	20.6	25.9	33.5	33.0	17.2
SS- VME - 12M - M2	12	1/8	4.8	13/16	20.6	25.9	36.0	23.6	22.8
SS- VME - 12M - M4	12	1/4	7.1	13/16	20.6	25.9	36.0	28.2	22.8
SS- VME - 12M - M6	12	3/8	9.5	13/16	20.6	25.9	36.0	28.2	22.8
SS- VME - 12M - M8	12	1/2	9.5	13/16	20.6	25.9	36.0	33.0	22.8
SS- VME - 12M - M12	12	3/4	9.5	1 1/16	27.0	29.7	39.8	36.8	22.8
SS- VME - 15M - M8	15	1/2	11.9	15/16	23.8	27.9	38.0	35.1	24.4
SS- VME - 16M - M6	16	3/8	9.5	15/16	23.8	27.9	38.0	30.2	24.4
SS- VME - 16M - M8	16	1/2	11.9	15/16	23.8	27.9	38.0	35.1	24.4
SS- VME - 16M - M12	16	3/4	12.7	1 1/16	27.0	29.7	39.8	36.8	24.4
SS- VME - 18M - M8	18	1/2	11.9	1 1/16	27.0	29.7	39.8	36.8	24.4
SS- VME - 18M - M12	18	3/4	15.1	1 1/16	27.0	29.7	39.8	36.8	24.4
SS- VME - 20M - M8	20	1/2	11.9	1 3/8	34.9	34.5	44.6	41.7	26.0
SS- VME - 20M - M12	20	3/4	15.9	1 3/8	34.9	34.5	44.6	41.7	26.0
SS- VME - 22M - M12	22	3/4	15.9	1 3/8	34.9	34.5	44.6	41.7	26.0
SS- VME - 22M - M16	22	1	18.3	1 3/8	34.9	34.5	44.6	46.5	26.0



# Tube Fittings / Zweiklemmring Verschraubung

## VME Series

### MALE ELBOW

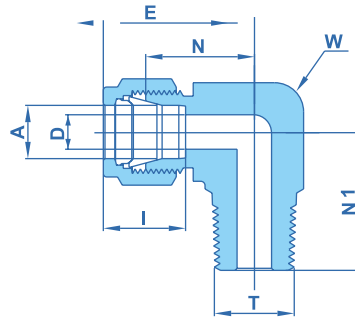

TUBE (INCH) MALE NPT THREAD

Ordering Information	A Tube O.D.		T (NPT)	D		W Wrench Flat		N		E		N1		I	
	inch	mm	inch	inch	mm	inch	mm	inch	mm	inch	mm	inch	mm	inch	mm
SS- VME - 02 - M2	1/8	3.17	1/8	.09	2.28	7/16	11.1	.67	17.02	.93	23.62	.70	17.78	.50	12.7
SS- VME - 02 - M4	1/8	3.17	1/4	.09	2.28	1/2	12.7	.71	18.03	.97	24.64	.92	23.37	.50	12.7
SS- VME - 03 - M2	3/16	4.76	1/8	.12	3.04	1/2	12.7	.74	18.80	1.00	25.40	.74	18.80	.54	13.7
SS- VME - 03 - M4	3/16	4.76	1/4	.12	3.04	1/2	12.7	.74	18.80	1.00	25.40	.92	23.37	.54	13.7
SS- VME - 04 - M2	1/4	6.35	1/8	.19	4.82	1/2	12.7	.77	19.56	1.06	26.92	.74	18.80	.60	15.2
SS- VME - 04 - M4	1/4	6.35	1/4	.19	4.82	1/2	12.7	.77	19.56	1.06	26.92	.92	23.37	.60	15.2
SS- VME - 04 - M6	1/4	6.35	3/8	.19	4.82	11/16	17.5	.88	22.35	1.17	29.71	1.03	26.16	.60	15.2
SS- VME - 04 - M8	1/4	6.35	1/2	.19	4.82	13/16	20.6	.96	24.38	1.25	31.75	1.30	33.02	.60	15.2
SS- VME - 05 - M2	5/16	7.93	1/8	.19	4.82	9/16	14.3	.84	21.34	1.13	28.70	.78	19.81	.64	16.2
SS- VME - 05 - M4	5/16	7.93	1/4	.25	6.35	9/16	14.3	.84	21.34	1.13	28.70	.96	24.38	.64	16.2
SS- VME - 05 - M6	5/16	7.93	3/8	.25	6.35	11/16	17.5	.91	23.11	1.20	30.48	1.03	26.16	.64	16.2
SS- VME - 06 - M2	3/8	9.52	1/8	.19	4.82	5/8	15.9	.91	23.11	1.20	30.48	.82	20.83	.66	16.8
SS- VME - 06 - M4	3/8	9.52	1/4	.28	7.11	5/8	15.9	.91	23.11	1.20	30.48	1.00	25.40	.66	16.8
SS- VME - 06 - M6	3/8	9.52	3/8	.28	7.11	11/16	17.5	.94	23.87	1.23	31.24	1.03	26.16	.66	16.8
SS- VME - 06 - M8	3/8	9.52	1/2	.28	7.11	13/16	20.6	1.02	25.90	1.31	33.28	1.30	33.02	.66	16.8
SS- VME - 06 - M12	3/8	9.52	3/4	.28	7.11	1 1/16	27.0	1.17	29.71	1.46	37.08	1.45	36.83	.66	16.8
SS- VME - 08 - M4	1/2	12.70	1/4	.28	7.11	13/16	20.6	1.02	25.90	1.42	36.07	1.11	28.19	.90	22.9
SS- VME - 08 - M6	1/2	12.70	3/8	.38	9.50	13/16	20.6	1.02	25.90	1.42	36.07	1.11	28.19	.90	22.9
SS- VME - 08 - M8	1/2	12.70	1/2	.41	10.41	13/16	20.6	1.02	25.90	1.42	36.07	1.30	33.02	.90	22.9
SS- VME - 08 - M12	1/2	12.70	3/4	.41	10.41	1 1/16	27.0	1.17	29.71	1.57	39.88	1.45	36.83	.90	22.9
SS- VME - 10 - M6	5/8	15.87	3/8	.38	9.61	15/16	23.8	1.10	27.94	1.50	38.10	1.19	30.23	.96	24.4
SS- VME - 10 - M8	5/8	15.87	1/2	.47	11.94	15/16	23.8	1.10	27.94	1.50	38.10	1.38	35.05	.96	24.4
SS- VME - 10 - M12	5/8	15.87	3/4	.50	12.70	1 1/16	27.0	1.17	29.71	1.57	39.88	1.45	36.83	.96	24.4
SS- VME - 12 - M8	3/4	19.05	1/2	.47	11.94	1 1/16	27.0	1.17	29.71	1.57	39.88	1.45	36.83	.96	24.4
SS- VME - 12 - M12	3/4	19.05	3/4	.62	15.74	1 1/16	27.0	1.17	29.71	1.57	39.88	1.45	36.83	.96	24.4

## MALE ADAPTER TUBE TO PIPE

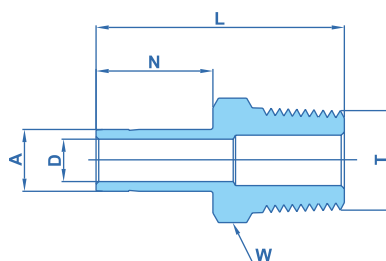

### TUBE (METRIC) MALE PIPE

Ordering Information	A Tube O.D.		T (NPT)	D		W Hex. Flat	N		L	
	mm	inch	inch	mm	mm	mm	mm	mm	mm	
SS- VMA - TW3M - M2	3		1/8	2.1		12		13.5		30.0
SS- VMA - TW3M - M4	3		1/4	2.1		14		13.5		35.3
SS- VMA - TW6M - M2	6		1/8	4.0		12		15.7		32.8
SS- VMA - TW6M - M4	6		1/4	4.0		14		15.7		38.1
SS- VMA - TW6M - M6	6		3/8	4.0		18		15.7		37.0
SS- VMA - TW6M - M8	6		1/2	4.0		22		15.7		43.4
SS- VMA - TW8M - M2	8		1/8	4.8		12		16.8		33.5
SS- VMA - TW8M - M4	8		1/4	5.6		14		16.8		39.1
SS- VMA - TW8M - M6	8		3/8	5.6		11/16 inch		16.8		37.8
SS- VMA - TW8M - M8	8		1/2	5.6		22		16.8		43.0
SS- VMA - TW10M - M4	10		1/4	7.1		9/16 inch		17.5		39.9
SS- VMA - TW10M - M6	10		3/8	7.1		18		17.5		40.6
SS- VMA - TW10M - M8	10		1/2	7.1		22		17.5		46.2
SS- VMA - TW12M - M4	12		1/4	7.1		16		23.1		46.5
SS- VMA - TW12M - M6	12		3/8	8.8		18		23.1		46.5
SS- VMA - TW12M - M8	12		1/2	8.8		22		23.1		52.0
SS- VMA - TW16M - M8	16		1/2	11.9		22		24.7		50.5

### TUBE (INCH) MALE PIPE

Ordering Information	A Tube O.D.		T (NPT)	D		W Hex. Flat	N		L	
	inch	mm	inch	inch	mm	inch	inch	mm	inch	mm
SS- VMA - TW2 - M2	1/8	3.17	1/8	.09	2.2	7/16	.53	13.45	1.16	29.5
SS- VMA - TW2 - M4	1/8	3.17	1/4	.09	2.2	9/16	.53	13.45	1.37	34.8
SS- VMA - TW3 - M2	3/16	4.76	1/8	.12	3.0	7/16	.56	14.20	1.19	30.2
SS- VMA - TW3 - M4	3/16	4.76	1/4	.12	3.0	9/16	.56	14.20	1.40	35.6
SS- VMA - TW4 - M2	1/4	6.35	1/8	.17	4.2	7/16	.62	15.75	1.25	31.8
SS- VMA - TW4 - M4	1/4	6.35	1/4	.17	4.2	9/16	.62	15.75	1.46	37.1
SS- VMA - TW4 - M6	1/4	6.35	3/8	.17	4.2	11/16	.62	15.75	1.49	37.9
SS- VMA - TW4 - M8	1/4	6.35	1/2	.17	4.2	7/8	.62	15.75	1.71	43.4
SS- VMA - TW5 - M2	5/16	7.93	1/8	.22	5.6	7/16	.66	16.75	1.29	32.7
SS- VMA - TW5 - M4	5/16	7.93	1/4	.22	5.6	9/16	.66	16.75	1.50	38.1
SS- VMA - TW6 - M2	3/8	9.52	1/8	.27	6.9	7/16	.69	17.50	1.32	33.5
SS- VMA - TW6 - M4	3/8	9.52	1/4	.27	6.9	9/16	.69	17.50	1.53	38.9
SS- VMA - TW6 - M6	3/8	9.52	3/8	.27	6.9	11/16	.69	17.50	1.56	39.6
SS- VMA - TW6 - M8	3/8	9.52	1/2	.27	6.9	7/8	.69	17.50	1.78	45.2
SS- VMA - TW8 - M4	1/2	12.70	1/4	.28	7.1	9/16	.91	23.10	1.75	44.5
SS- VMA - TW8 - M6	1/2	12.70	3/8	.37	9.4	11/16	.91	23.10	1.78	45.2
SS- VMA - TW8 - M8	1/2	12.70	1/2	.37	9.4	7/8	.91	23.10	2.0	50.8
SS- VMA - TW10 - M6	5/8	15.87	3/8	.37	9.5	11/16	.97	24.65	1.81	47.6
SS- VMA - TW10 - M8	5/8	15.87	1/2	.47	11.9	7/8	.97	24.65	2.06	52.3
SS- VMA - TW10 - M12	5/8	15.87	3/4	.50	12.7	1 1/16	.97	24.65	2.06	52.3
SS- VMA - TW12 - M8	3/4	19.05	1/2	.47	11.9	7/8	.97	24.65	2.06	52.3
SS- VMA - TW12 - M12	3/4	19.05	3/4	.59	15.0	1 1/16	.97	24.65	2.06	52.3
SS- VMA - TW12 - M16	3/4	19.05	1	.59	15.0	1 3/8	.97	24.65	2.28	57.3

### FEMALE ADAPTER TUBE TO PIPE

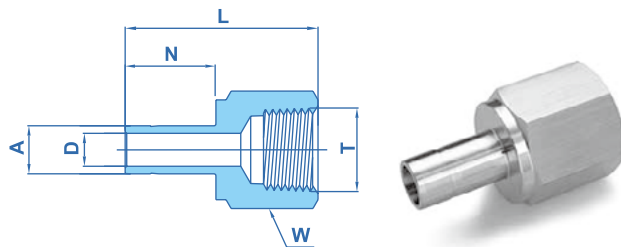

TUBE (METRIC) FEMALE PIPE

Ordering Information	A Tube O.D.		T (NPT)	D		W Hex. Flat	N		L	
	mm	mm	inch	mm	mm	mm	mm	mm	mm	mm
SS- VFA - TW3M - F2	3		1/8	2.1		14	13.5		31.5	
SS- VFA - TW3M - F4	3		1/4	2.1		19	13.5		35.3	
SS- VFA - TW4M - F4	4		1/4	2.2		19	14.2		35.0	
SS- VFA - TW6M - F2	6		1/8	4.0		14	15.7		32.5	
SS- VFA - TW6M - F4	6		1/4	4.0		19	15.7		37.1	
SS- VFA - TW6M - F6	6		3/8	4.0		22	15.7		39.6	
SS- VFA - TW6M - F8	6		1/2	4.0		27	15.7		45.5	
SS- VFA - TW8M - F2	8		1/8	5.6		14	16.8		34.3	
SS- VFA - TW8M - F4	8		1/4	5.6		19	16.8		37.6	
SS- VFA - TW8M - F8	8		1/2	5.6		27	16.8		46.0	
SS- VFA - TW10M - F4	10		1/4	7.1		19	17.5		38.1	
SS- VFA - TW10M - F6	10		3/8	7.1		22	17.5		40.1	
SS- VFA - TW10M - F8	10		1/2	7.1		27	17.5		46.5	
SS- VFA - TW12M - F4	12		1/4	8.8		19	23.1		43.4	
SS- VFA - TW12M - F6	12		3/8	8.8		22	23.1		45.5	
SS- VFA - TW12M - F8	12		1/2	8.8		27	23.1		52.3	
SS- VFA - TW16M - F6	16		3/8	12.7		24	24.7		48.0	
SS- VFA - TW16M - F8	16		1/2	12.7		27	24.7		53.1	
SS- VFA - TW20M - F8	20		1/2	15.1		27	26.6		56.0	
SS- VFA - TW20M - F12	20		3/4	15.1		35	26.6		56.0	

TUBE (INCH) FEMALE PIPE

Ordering Information	A Tube O.D.		T (NPT)	D		W Hex. Flat	N		L	
	inch	mm	inch	inch	mm	inch	inch	mm	inch	mm
SS- VFA - TW2 - F2	1/8	3.17	1/8	.09	2.2	9/16	.53	13.45	1.24	31.5
SS- VFA - TW2 - F4	1/8	3.17	1/4	.09	2.2	3/4	.53	13.45	1.39	35.3
SS- VFA - TW3 - F4	3/16	4.76	1/4	.12	3.0	3/4	.56	14.20	1.41	35.8
SS- VFA - TW4 - F2	1/4	6.35	1/8	.17	4.2	9/16	.62	15.75	1.30	33.0
SS- VFA - TW4 - F4	1/4	6.35	1/4	.17	4.2	3/4	.62	15.75	1.46	37.1
SS- VFA - TW4 - F6	1/4	6.35	3/8	.17	4.2	7/8	.62	15.75	1.55	39.4
SS- VFA - TW4 - F8	1/4	6.35	1/2	.17	4.2	1 1/16	.62	15.75	1.79	45.5
SS- VFA - TW5 - F4	5/16	7.93	1/4	.22	5.6	3/4	.66	16.75	1.48	37.6
SS- VFA - TW6 - F2	3/8	9.52	1/8	.27	6.9	9/16	.69	17.50	1.35	34.3
SS- VFA - TW6 - F4	3/8	9.52	1/4	.27	6.9	3/4	.69	17.50	1.50	38.1
SS- VFA - TW6 - F6	3/8	9.52	3/8	.27	6.9	7/8	.69	17.50	1.59	40.4
SS- VFA - TW6 - F8	3/8	9.52	1/2	.27	6.9	1 1/16	.69	17.50	1.84	46.7
SS- VFA - TW8 - F4	1/2	12.70	1/4	.37	9.4	3/4	.91	23.10	1.71	43.4
SS- VFA - TW8 - F6	1/2	12.70	3/8	.37	9.4	7/8	.91	23.10	1.79	45.5
SS- VFA - TW8 - F8	1/2	12.70	1/2	.37	9.4	1 1/16	.91	23.10	2.05	52.1
SS- VFA - TW10 - F8	5/8	15.87	1/2	.50	12.7	1 1/16	.97	24.65	2.09	53.1
SS- VFA - TW12 - F8	3/4	19.05	1/2	.59	15.0	1 1/16	.97	24.65	2.08	52.8
SS- VFA - TW12 - F12	3/4	19.05	3/4	.59	15.0	1 5/16	.97	24.65	2.16	54.9
SS- VFA - TW12 - F16	3/4	19.05	1	.59	15.0	1 5/8	.97	24.65	2.30	58.4

## FEMALE CONNECTOR

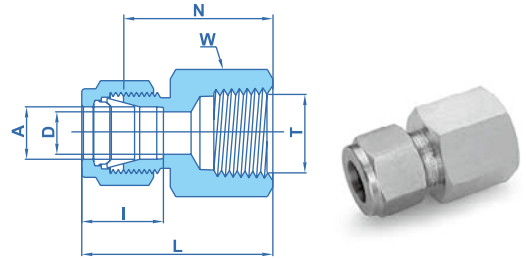

TUBE (METRIC) TO FEMALE NPT THREAD

Ordering Information	A Tube O.D.	T (NPT)	D	W Hex. Flat	N	L	I
	mm	inch	mm	mm	mm	mm	mm
SS- VFC - 3M - F2	3	1/8	2.4	14	22.1	28.7	12.9
SS- VFC - 3M - F4	3	1/4	2.4	19	26.9	33.5	12.9
SS- VFC - 4M - F2	4	1/8	2.4	14	23.1	29.7	13.7
SS- VFC - 6M - F2	6	1/8	4.8	14	23.9	31.3	15.3
SS- VFC - 6M - F4	6	1/4	4.8	19	28.4	35.8	15.3
SS- VFC - 6M - F6	6	3/8	4.8	22	30.2	37.6	15.3
SS- VFC - 6M - F8	6	1/2	4.8	27	35.1	42.5	15.3
SS- VFC - 8M - F2	8	1/8	6.4	15	24.6	32.1	16.2
SS- VFC - 8M - F4	8	1/4	6.4	19	29.5	37.0	16.2
SS- VFC - 8M - F6	8	3/8	6.4	22	31.0	38.5	16.2
SS- VFC - 8M - F8	8	1/2	6.4	27	35.8	43.3	16.2
SS- VFC - 10M - F4	10	1/4	7.9	19	30.2	37.8	17.2
SS- VFC - 10M - F6	10	3/8	7.9	22	31.8	39.4	17.2
SS- VFC - 10M - F8	10	1/2	7.9	27	36.6	44.2	17.2
SS- VFC - 12M - F4	12	1/4	9.5	22	30.2	40.3	22.8
SS- VFC - 12M - F6	12	3/8	9.5	22	31.8	41.9	22.8
SS- VFC - 12M - F8	12	1/2	9.5	27	36.6	46.7	22.8
SS- VFC - 15M - F8	15	1/2	11.9	27	36.6	46.7	24.4
SS- VFC - 16M - F8	16	1/2	12.7	27	36.8	46.9	24.4
SS- VFC - 20M - F8	20	1/2	15.9	30	37.8	47.9	26.0
SS- VFC - 20M - F12	20	3/4	15.9	35	39.6	49.7	26.0
SS- VFC - 22M - F12	22	3/4	18.3	35	39.6	49.7	26.0
SS- VFC - 22M - F16	22	1	18.3	41	47.8	57.9	26.0
SS- VFC - 25M - F12	25	3/4	21.8	35	41.1	53.4	31.3
SS- VFC - 25M - F16	25	1	21.8	41	50.0	62.3	31.3

## FEMALE CONNECTOR

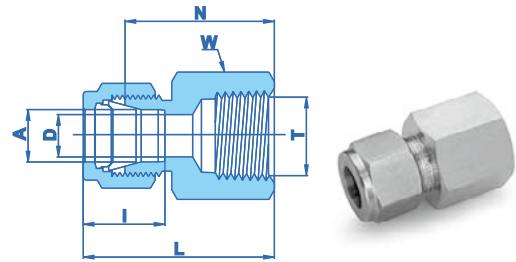

TUBE (INCH) TO FEMALE NPT THREAD

Ordering Information	A Tube O.D.		T (NPT)	D		W Hex Flat	N		L		I	
	inch	mm	inch	inch	mm	inch	inch	mm	inch	mm	inch	mm
SS- VFC - 01 - F1	1/16	1.58	1/16	.05	1.27	7/16	.78	19.81	.93	23.62	.34	8.6
SS- VFC - 01 - F2	1/16	1.58	1/8	.05	1.27	9/16	.81	20.57	.96	24.38	.34	8.6
SS- VFC - 02 - F2	1/8	3.17	1/8	.09	2.28	9/16	.87	22.10	1.13	28.70	.50	12.7
SS- VFC - 02 - F4	1/8	3.17	1/4	.09	2.28	3/4	1.06	26.92	1.32	33.52	.50	12.7
SS- VFC - 03 - F2	3/16	4.76	1/8	.12	3.04	9/16	.91	23.11	1.17	29.71	.54	13.7
SS- VFC - 04 - F2	1/4	6.35	1/8	.19	4.82	9/16	.94	23.87	1.23	31.24	.60	15.2
SS- VFC - 04 - F4	1/4	6.35	1/4	.19	4.82	3/4	1.12	28.44	1.41	35.81	.60	15.2
SS- VFC - 04 - F6	1/4	6.35	3/8	.19	4.82	7/8	1.19	30.22	1.48	37.59	.60	15.2
SS- VFC - 04 - F8	1/4	6.35	1/2	.19	4.82	1 1/16	1.38	35.00	1.67	42.42	.60	15.2
SS- VFC - 05 - F2	5/16	7.93	1/8	.25	6.35	9/16	.97	24.63	1.26	32.00	.64	16.2
SS- VFC - 05 - F4	5/16	7.93	1/4	.25	6.35	3/4	1.16	29.46	1.45	36.83	.64	16.2
SS- VFC - 06 - F2	3/8	9.52	1/8	.28	7.11	5/8	1.00	25.40	1.29	32.76	.66	16.8
SS- VFC - 06 - F4	3/8	9.52	1/4	.28	7.11	3/4	1.19	30.22	1.48	37.59	.66	16.8
SS- VFC - 06 - F6	3/8	9.52	3/8	.28	7.11	7/8	1.25	31.75	1.54	39.11	.66	16.8
SS- VFC - 06 - F8	3/8	9.52	1/2	.28	7.11	1 1/16	1.44	36.57	1.73	43.94	.66	16.8
SS- VFC - 06 - F12	3/8	9.52	3/4	.28	7.11	1 5/16	1.59	40.40	1.88	47.75	.66	16.8
SS- VFC - 08 - F4	1/2	12.70	1/4	.41	10.41	13/16	1.19	30.22	1.59	40.38	.90	22.9
SS- VFC - 08 - F6	1/2	12.70	3/8	.41	10.41	7/8	1.25	31.75	1.65	41.91	.90	22.9
SS- VFC - 08 - F8	1/2	12.70	1/2	.41	10.41	1 1/16	1.44	36.57	1.84	46.73	.90	22.9
SS- VFC - 08 - F12	1/2	12.70	3/4	.41	10.41	1 5/16	1.50	38.10	1.90	48.26	.90	22.9
SS- VFC - 10 - F6	5/8	15.87	3/8	.50	12.70	15/16	1.25	31.75	1.65	41.91	.96	24.4
SS- VFC - 10 - F8	5/8	15.87	1/2	.50	12.70	1 1/16	1.44	36.57	1.84	46.73	.96	24.4
SS- VFC - 10 - F12	5/8	15.87	3/4	.50	12.70	1 5/16	1.50	38.10	1.90	48.26	.96	24.4
SS- VFC - 12 - F8	3/4	19.05	1/2	.62	15.75	1 1/16	1.44	36.57	1.84	46.73	.96	24.4
SS- VFC - 12 - F12	3/4	19.05	3/4	.62	15.75	1 5/16	1.50	38.10	1.90	48.26	.96	24.4
SS- VFC - 14 - F12	7/8	22.22	3/4	.72	18.28	1 5/16	1.56	39.62	1.96	49.78	1.02	25.9

## FEMALE ELBOW

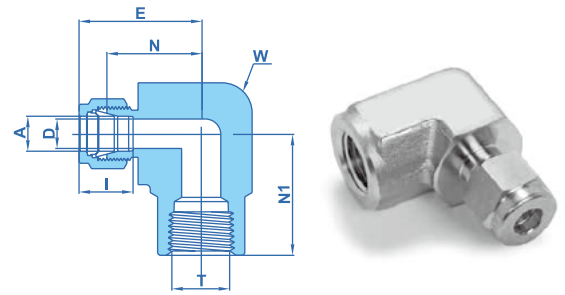

TUBE (METRIC) TO FEMALE NPT THREAD													
Ordering Information	A Tube O.D.		T (NPT)	D		W Wrench Flat		N		E	N1		I
	mm	inch	inch	mm	inch	mm	mm	mm	mm	mm	mm	mm	
SS- VFE - 6M - F2	6		1/8	4.8		1/2	12.7	19.6		27.0		19.0	15.3
SS- VFE - 6M - F4	6		1/4	4.8		11/16	17.5	22.4		29.8		22.4	15.3
SS- VFE - 6M - F8	6		1/2	4.8		1 1/16	27.0	27.2		34.6		28.4	15.3
SS- VFE - 8M - F4	8		1/4	6.4		11/16	17.5	23.1		30.6		22.4	16.2
SS- VFE - 10M - F2	10		1/8	7.9		11/16	17.5	23.9		31.5		19.0	17.2
SS- VFE - 10M - F4	10		1/4	7.9		13/16	20.6	25.9		33.5		22.4	17.2
SS- VFE - 12M - F4	12		1/4	9.5		13/16	20.6	25.9		36.0		22.4	22.8
SS- VFE - 12M - F8	12		1/2	9.5		1 1/16	27.0	28.7		38.8		28.4	22.8
SS- VFE - 16M - F8	16		1/2	12.7		1 1/16	27.0	29.7		39.8		28.4	24.4

TUBE (INCH) TO FEMALE NPT THREAD															
Ordering Information	A Tube O.D.		T (NPT)	D		W Wrench Flat		N		E		N1		I	
	inch	mm	inch	inch	mm	inch	mm	inch	mm	inch	mm	inch	mm	inch	mm
SS- VFE - 02 - F2	1/8	3.17	1/8	.09	2.28	1/2	12.7	.71	18.03	.97	24.64	.75	19.05	.50	12.7
SS- VFE - 02 - F4	1/8	3.17	1/4	.09	2.28	11/16	17.5	.82	20.80	1.08	27.43	.88	22.40	.50	12.7
SS- VFE - 03 - F2	3/16	4.76	1/8	.12	3.04	1/2	12.7	.74	18.80	1.00	25.40	.75	19.05	.54	13.7
SS- VFE - 04 - F2	1/4	6.35	1/8	.19	4.82	1/2	12.7	.77	19.55	1.06	26.92	.75	19.05	.60	15.2
SS- VFE - 04 - F4	1/4	6.35	1/4	.19	4.82	11/16	17.5	.88	22.40	1.17	29.72	.88	22.40	.60	15.2
SS- VFE - 04 - F6	1/4	6.35	3/8	.19	4.82	15/16	23.8	.96	24.38	1.25	31.75	.88	22.40	.60	15.2
SS- VFE - 04 - F8	1/4	6.35	1/2	.19	4.82	1 1/16	27.0	1.07	27.18	1.36	34.54	1.12	28.45	.60	15.2
SS- VFE - 05 - F2	5/16	7.93	1/8	.25	6.35	9/16	14.3	.84	21.30	1.13	28.70	.75	19.05	.64	16.2
SS- VFE - 05 - F4	5/16	7.93	1/4	.25	6.35	11/16	17.5	.91	23.11	1.20	30.48	.88	22.40	.64	16.2
SS- VFE - 06 - F2	3/8	9.52	1/8	.28	7.11	5/8	15.9	.91	23.11	1.20	30.48	.75	19.05	.66	16.8
SS- VFE - 06 - F4	3/8	9.52	1/4	.28	7.11	11/16	17.5	0.94	23.87	1.23	31.24	.88	22.40	.66	16.8
SS- VFE - 06 - F6	3/8	9.52	3/8	.28	7.11	15/16	23.8	1.02	25.90	1.31	33.27	.88	22.40	.66	16.8
SS- VFE - 06 - F8	3/8	9.52	1/2	.28	7.11	1 1/16	27.0	1.13	28.70	1.42	36.07	1.12	28.45	.66	16.8
SS- VFE - 08 - F4	1/2	12.70	1/4	.41	10.41	13/16	20.6	1.02	25.90	1.42	36.07	.88	22.40	.90	22.9
SS- VFE - 08 - F6	1/2	12.70	3/8	.41	10.41	15/16	23.8	1.02	25.90	1.42	36.07	.88	22.40	.90	22.9
SS- VFE - 08 - F8	1/2	12.70	1/2	.41	10.41	1 1/16	27.0	1.13	28.70	1.53	36.86	1.12	28.45	.90	22.9
SS- VFE - 10 - F6	5/8	15.87	3/8	.50	12.70	15/16	23.8	1.10	27.90	1.50	38.10	.88	22.40	.96	24.4
SS- VFE - 10 - F8	5/8	15.87	1/2	.50	12.70	1 1/16	27.0	1.17	29.70	1.57	39.86	1.12	28.45	.96	24.4
SS- VFE - 12 - F8	3/4	19.05	1/2	.62	15.74	1 1/16	27.0	1.17	29.70	1.57	39.86	1.12	28.45	.96	24.4
SS- VFE - 12 - F12	3/4	19.05	3/4	.62	15.74	1 3/8	34.9	1.36	34.54	1.76	44.70	1.25	31.75	.96	24.4
SS- VFE - 14 - F12	7/8	22.22	3/4	.72	18.28	1 3/8	34.9	1.36	34.54	1.76	44.70	1.25	31.75	1.02	25.9

# Tube Fittings / Zweiklemmring Verschraubung

## VU Series

### UNION

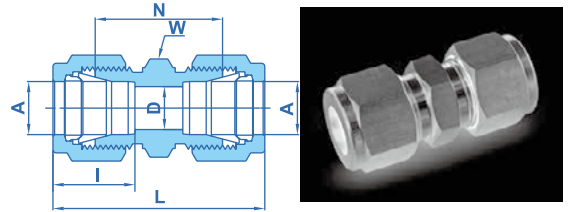

TUBE (METRIC) TO TUBE (METRIC)

Ordering Information	A Tube O.D.		D		W Hex. Flat		N		L		I	
	mm	mm	mm	mm	mm	mm	mm	mm	mm	mm	mm	mm
SS- VU - 2M	2		1.7		12		22.4		35.6		12.9	
SS- VU - 3M	3		2.4		12		22.1		35.3		12.9	
SS- VU - 4M	4		2.4		12		24.1		37.3		13.7	
SS- VU - 6M	6		4.8		14		26.2		41.0		15.3	
SS- VU - 8M	8		6.4		15		28.2		43.2		16.2	
SS- VU - 10M	10		7.9		18		31.0		46.2		17.2	
SS- VU - 12M	12		9.5		22		31.0		51.2		22.8	
SS- VU - 14M	14		11.1		24		31.8		52.0		24.4	
SS- VU - 15M	15		11.9		24		31.8		52.0		24.4	
SS- VU - 16M	16		12.7		24		31.8		52.0		24.4	
SS- VU - 18M	18		15.1		27		33.3		53.5		24.4	
SS- VU - 20M	20		15.9		30		34.8		55.0		26.0	
SS- VU - 22M	22		18.3		30		34.8		55.0		26.0	

TUBE (INCH) TO TUBE (INCH)

Ordering Information	A Tube O.D.		D		W Hex. Flat		N		L		I	
	inch	mm	inch	mm	inch	mm	inch	mm	inch	mm	inch	mm
SS- VU - 01	1/16	1.58	.05	1.27	5/16	.69	17.52	.99	25.14	.34	8.6	
SS- VU - 02	1/8	3.17	.09	2.28	7/16	.88	22.35	1.40	35.56	.50	12.7	
SS- VU - 03	3/16	4.76	.12	3.04	7/16	.95	24.13	1.47	37.33	.54	13.7	
SS- VU - 04	1/4	6.35	.19	4.82	1/2	1.03	26.16	1.61	40.89	.60	15.2	
SS- VU - 05	5/16	7.93	.25	6.35	9/16	1.11	28.19	1.69	42.92	.64	16.2	
SS- VU - 06	3/8	9.52	.28	7.11	5/8	1.19	30.22	1.77	44.95	.66	16.8	
SS- VU - 08	1/2	12.70	.41	10.41	13/16	1.22	30.98	2.02	51.30	.90	22.9	
SS- VU - 10	5/8	15.87	.50	12.70	15/16	1.25	31.75	2.05	52.07	.96	24.4	
SS- VU - 12	3/4	19.05	.62	15.75	1 1/16	1.31	33.27	2.11	53.59	.96	24.4	
SS- VU - 14	7/8	22.22	.72	18.28	1 3/16	1.37	34.80	2.17	55.11	1.02	25.9	

## REDUCING UNION

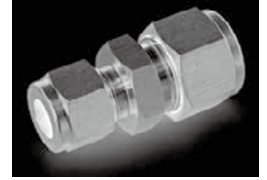
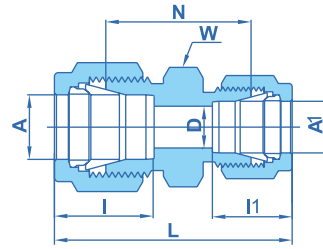

TUBE (METRIC) TO TUBE (METRIC)

Ordering Information	A	A1	D	W Hex. Flat	N	L	I	I1
	Tube O.D.	Tube O.D.						
	mm	mm	mm	mm	mm	mm	mm	mm
SS- VRU - 3M - 2M	3	2	1.7	12	22.1	35.3	12.9	12.9
SS- VRU - 6M - 2M	6	2	1.7	14	24.6	38.6	15.3	12.9
SS- VRU - 6M - 3M	6	3	2.4	14	24.6	38.6	15.3	12.9
SS- VRU - 6M - 4M	6	4	2.4	14	25.4	39.4	15.3	13.7
SS- VRU - 8M - 6M	8	6	4.8	15	27.4	42.3	16.2	15.3
SS- VRU - 10M - 6M	10	6	4.8	18	29.5	44.5	17.2	15.3
SS- VRU - 10M - 8M	10	8	6.4	18	30.0	45.1	17.2	16.2
SS- VRU - 12M - 6M	12	6	4.8	22	29.5	47.0	22.8	15.3
SS- VRU - 12M - 8M	12	8	6.4	22	30.2	47.8	22.8	16.2
SS- VRU - 12M - 10M	12	10	7.9	22	31.0	48.7	22.8	17.2
SS- VRU - 16M - 10M	16	10	7.9	24	31.8	49.5	24.4	17.2
SS- VRU - 16M - 12M	16	12	9.5	24	31.8	52.0	24.4	22.8
SS- VRU - 18M - 12M	18	12	9.5	27	33.3	53.5	24.4	22.8

TUBE (METRIC) TO TUBE (INCH)

Ordering Information	A	A1	D	W Hex. Flat	N	L	I	I1
	Tube O.D.	Tube O.D.						
	mm	inch	mm	mm	mm	mm	mm	mm
SS- VRU - 2M - 04	2	1/4	1.7	14	24.6	38.6	12.9	15.2
SS- VRU - 3M - 02	3	1/8	2.4	12	22.1	35.2	12.9	12.7
SS- VRU - 4M - 02	4	1/8	2.4	12	23.4	36.5	13.7	12.7
SS- VRU - 4M - 04	4	1/4	2.4	14	25.4	39.4	13.7	15.2
SS- VRU - 6M - 02	6	1/8	2.4	14	24.6	38.5	15.3	12.7
SS- VRU - 6M - 04	6	1/4	4.8	14	26.2	41.0	15.3	15.2
SS- VRU - 6M - 05	6	5/16	4.8	14	27.4	42.3	15.3	16.2
SS- VRU - 8M - 02	8	1/8	2.4	15	25.7	39.8	16.2	12.7
SS- VRU - 8M - 04	8	1/4	4.8	15	27.4	42.3	16.2	15.2
SS- VRU - 8M - 06	8	3/8	6.4	16	29.5	44.3	16.2	16.8
SS- VRU - 10M - 02	10	1/8	2.4	18	27.7	41.8	17.2	12.7
SS- VRU - 10M - 04	10	1/4	4.8	18	29.5	44.5	17.2	15.2
SS- VRU - 10M - 05	10	5/16	6.4	18	30.0	45.1	17.2	16.2
SS- VRU - 10M - 06	10	3/8	7.1	18	31.0	45.9	17.2	16.8
SS- VRU - 12M - 05	12	5/16	6.4	22	30.2	47.8	22.8	16.2
SS- VRU - 12M - 06	12	3/8	7.1	22	31.0	48.4	22.8	16.8
SS- VRU - 12M - 08	12	1/2	9.5	22	31.0	51.2	22.8	22.9
SS- VRU - 15M - 08	15	1/2	10.3	24	31.8	52.0	24.4	22.9
SS- VRU - 16M - 10	16	5/8	12.7	24	31.8	52.0	24.4	24.4
SS- VRU - 18M - 12	18	3/4	15.1	27	33.3	53.5	24.4	24.4



# Tube Fittings / Zweiklemmring Verschraubung

## VRU Series & VRUE Series

### REDUCING UNION

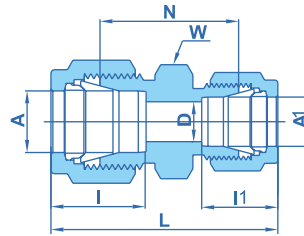

TUBE (INCH) TO TUBE (INCH)

Ordering Information	A Tube O.D.		A1 Tube O.D.		D		W Hex. Flat		N		L		I		I1	
	inch	mm	inch	mm	inch	mm	inch	mm	inch	mm	inch	mm	inch	mm	inch	mm
SS-VRU-03-02	3/16	4.76	1/8	3.17	.09	2.28	7/16	.92	23.36	1.44	36.57	.54	13.7	.50	12.7	
SS-VRU-04-02	1/4	6.35	1/8	3.17	.09	2.28	1/2	.97	24.63	1.52	38.60	.60	15.2	.50	12.7	
SS-VRU-04-03	1/4	6.35	3/16	4.76	.12	3.04	1/2	1.00	25.40	1.55	37.37	.60	15.2	.54	13.7	
SS-VRU-05-02	5/16	7.93	1/8	3.17	.09	2.28	9/16	1.01	25.65	1.56	39.62	.64	16.2	.50	12.7	
SS-VRU-05-04	5/16	7.93	1/4	6.35	.19	4.82	9/16	1.08	27.43	1.66	42.16	.64	16.2	.60	15.2	
SS-VRU-06-01	3/8	9.52	1/16	1.58	.05	1.27	5/8	1.00	25.40	1.44	36.58	.66	16.8	.34	8.6	
SS-VRU-06-02	3/8	9.52	1/8	3.17	.09	2.28	5/8	1.06	26.92	1.61	40.89	.66	16.8	.50	12.7	
SS-VRU-06-04	3/8	9.52	1/4	6.35	.19	4.82	5/8	1.12	28.44	1.70	43.18	.66	16.8	.60	15.2	
SS-VRU-06-05	3/8	9.52	5/16	7.93	.25	6.35	5/8	1.16	29.46	1.74	44.19	.66	16.8	.64	16.2	
SS-VRU-08-02	1/2	12.70	1/8	3.17	.09	2.28	13/16	1.12	28.44	1.78	45.21	.90	22.9	.50	12.7	
SS-VRU-08-04	1/2	12.70	1/4	6.35	.19	4.82	13/16	1.16	29.46	1.85	46.99	.90	22.9	.60	15.2	
SS-VRU-08-06	1/2	12.70	3/8	9.52	.28	7.11	13/16	1.22	30.98	1.91	48.51	.90	22.9	.66	16.8	
SS-VRU-10-06	5/8	15.87	3/8	9.52	.28	7.11	15/16	1.25	31.75	1.94	49.27	.96	24.4	.66	16.8	
SS-VRU-10-08	5/8	15.87	1/2	12.70	.41	10.41	15/16	1.25	31.75	2.05	52.07	.96	24.4	.90	22.9	
SS-VRU-12-04	3/4	19.05	1/4	6.35	.19	4.82	1 1/16	1.25	31.75	1.94	49.28	.96	24.4	.60	15.2	
SS-VRU-12-06	3/4	19.05	3/8	9.52	.28	7.11	1 1/16	1.31	33.27	2.00	50.80	.96	24.4	.66	16.8	
SS-VRU-12-08	3/4	19.05	1/2	12.70	.41	10.41	1 1/16	1.31	33.27	2.11	53.59	.96	24.4	.90	22.9	
SS-VRU-12-10	3/4	19.05	5/8	15.87	.50	12.70	1 1/16	1.31	33.27	2.11	53.59	.96	24.4	.96	24.4	

### REDUCING UNION ELBOW

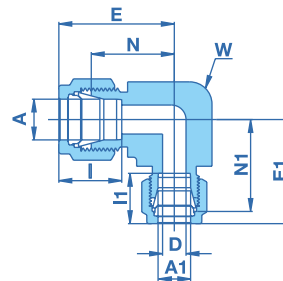

TUBE (METRIC) TO TUBE (INCH)

Ordering Information	A Tube O.D.		A1 Tube O.D.		E		E1		I		I1		D		W Wrench Flat		N		N1	
	mm	inch	mm	inch	mm	mm	mm	mm	mm	mm	mm	mm	mm	mm	in	mm	mm	mm	mm	mm
SS-VRUE-6M-04	6	1/4	27.0	26.9	15.3	15.2	4.8	1/2	12.7	19.6	19.6									
SS-VRUE-8M-04	8	1/4	28.8	28.7	16.2	15.2	4.8	9/16	14.3	21.3	21.3									

TUBE (INCH) TO TUBE (INCH)

Ordering Information	A Tube O.D.		A1 Tube O.D.		E		E1		I		I1		D		W Wrench Flat		N		N1	
	in	mm	in	mm	in	mm	in	mm	in	mm	in	mm	in	mm	in	mm	in	mm	in	mm
SS-VRUE-06-04	3/8	9.52	1/4	6.35	1.20	30.48	1.20	30.48	.66	16.8	.60	15.2	.19	4.82	5/8	15.9	.91	23.11	.91	23.11
SS-VRUE-10-06	5/8	15.87	3/8	9.52	1.50	38.10	1.39	35.31	.96	24.4	.66	16.8	.28	7.11	15/16	23.8	1.10	27.94	1.10	27.94

## UNION ELBOW

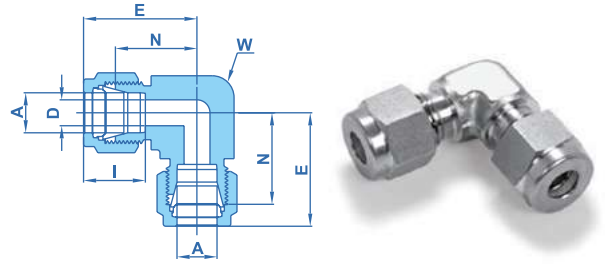

### TUBE (METRIC)

Ordering Information	A Tube O.D.		D		W Wrench Flat		N		E		I	
	mm	mm	mm	mm	inch	mm	mm	mm	mm	mm	mm	mm
SS- VUE - 3M	3		2.4		3/8	9.5		15.7		22.3		12.9
SS- VUE - 4M	4		2.4		1/2	12.7		18.8		25.4		13.7
SS- VUE - 6M	6		4.8		1/2	12.7		19.6		27.0		15.3
SS- VUE - 8M	8		6.4		9/16	14.3		21.3		28.8		16.2
SS- VUE - 10M	10		7.9		11/16	17.5		23.9		31.5		17.2
SS- VUE - 12M	12		9.5		13/16	20.6		25.9		36.0		22.8
SS- VUE - 14M	14		11.1		15/16	23.8		27.9		38.0		24.4
SS- VUE - 15M	15		11.9		15/16	23.8		27.9		38.0		24.4
SS- VUE - 16M	16		12.7		15/16	23.8		27.9		38.0		24.4
SS- VUE - 18M	18		15.1		1 1/16	27.0		29.7		39.8		24.4
SS- VUE - 20M	20		15.9		1 3/8	34.9		34.5		44.6		26.0
SS- VUE - 22M	22		18.3		1 3/8	34.9		34.5		44.6		26.0

### TUBE (INCH)

Ordering Information	A Tube O.D.		D		W Wrench Flat		N		E		I	
	inch	mm	inch	mm	inch	mm	inch	mm	inch	mm	inch	mm
SS- VUE - 01	1/16	1.58	.05	1.27	3/8	9.5	.55	14.00	.70	17.80	.34	.86
SS- VUE - 02	1/8	3.17	.09	2.28	3/8	9.5	.62	15.74	.88	22.35	.50	12.7
SS- VUE - 03	3/16	4.76	.12	3.04	1/2	12.7	.74	18.80	1.00	25.40	.54	13.7
SS- VUE - 04	1/4	6.35	.19	4.82	1/2	12.7	.77	19.55	1.06	26.92	.60	15.2
SS- VUE - 05	5/16	7.93	.25	6.35	9/16	14.3	.84	21.33	1.13	28.70	.64	16.2
SS- VUE - 06	3/8	9.52	.28	7.11	5/8	15.9	.91	23.11	1.20	30.48	.66	16.8
SS- VUE - 08	1/2	12.70	.41	10.41	13/16	20.6	1.02	25.90	1.42	36.06	.90	22.9
SS- VUE - 10	5/8	15.87	.50	12.70	15/16	23.8	1.10	27.94	1.50	38.10	.96	24.4
SS- VUE - 12	3/4	19.05	.62	15.74	1 1/16	27.0	1.17	29.70	1.57	39.90	.96	24.4
SS- VUE - 14	7/8	22.22	.72	18.29	1 3/8	34.9	1.36	34.54	1.76	44.70	1.02	25.9

### UNION TEE

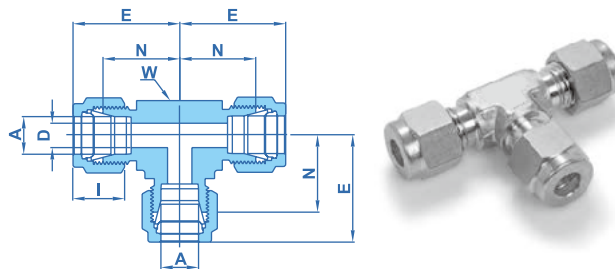

#### ALL TUBE (METRIC)

Ordering Information	A Tube O.D.		D		W Wrench Flat		N		E		I	
	mm	mm	mm	mm	inch	mm	mm	mm	mm	mm	mm	mm
SS- VUT - 2M	2		1.7		3/8	9.5		15.7		22.3		12.9
SS- VUT - 3M	3		2.4		3/8	9.5		15.7		22.3		12.9
SS- VUT - 4M	4		2.4		1/2	12.7		18.8		25.4		13.7
SS- VUT - 6M	6		4.8		1/2	12.7		19.6		27.0		15.3
SS- VUT - 8M	8		6.4		5/8	15.9		22.4		29.9		16.2
SS- VUT - 10M	10		7.9		11/16	17.5		23.9		31.5		17.2
SS- VUT - 12M	12		9.5		13/16	20.6		25.9		36.0		22.8
SS- VUT - 14M	14		11.1		15/16	23.8		28.7		38.8		24.4
SS- VUT - 15M	15		11.9		15/16	23.8		28.7		38.8		24.4
SS- VUT - 16M	16		12.7		15/16	23.8		28.7		38.8		24.4
SS- VUT - 18M	18		15.1		1 1/16	27.0		29.7		39.8		24.4
SS- VUT - 20M	20		15.9		1 3/8	34.9		34.5		44.6		26.0
SS- VUT - 22M	22		18.3		1 3/8	34.9		34.5		44.6		26.0

#### ALL TUBE (INCH)

Ordering Information	A Tube O.D.		D		W Wrench Flat		N		E		I	
	inch	mm	inch	mm	inch	mm	inch	mm	inch	mm	inch	mm
SS- VUT - 01	1/16	1.58	.05	1.27	3/8	9.5	.55	14.00	.70	17.80	.34	8.6
SS- VUT - 02	1/8	3.17	.09	2.28	3/8	9.5	.62	15.74	.88	22.35	.50	12.7
SS- VUT - 03	3/16	4.76	.12	3.04	1/2	12.7	.70	17.80	.96	24.40	.54	13.7
SS- VUT - 04	1/4	6.35	.19	4.82	1/2	12.7	.77	19.55	1.06	26.90	.60	15.2
SS- VUT - 05	5/16	7.93	.25	6.35	5/8	15.9	.88	22.35	1.17	29.71	.64	16.2
SS- VUT - 06	3/8	9.52	.28	7.11	5/8	15.9	.91	23.11	1.20	30.48	.66	16.8
SS- VUT - 08	1/2	12.70	.41	10.41	13/16	20.6	1.02	25.90	1.42	36.06	.90	22.9
SS- VUT - 10	5/8	15.87	.50	12.70	15/16	23.8	1.13	28.70	1.53	38.90	.96	24.4
SS- VUT - 12	3/4	19.05	.62	15.74	1 1/16	27.0	1.17	29.70	1.57	39.90	.96	24.4
SS- VUT - 14	7/8	22.22	.72	18.29	1 3/8	34.9	1.36	34.54	1.76	44.70	1.02	25.9

## REDUCING TEE

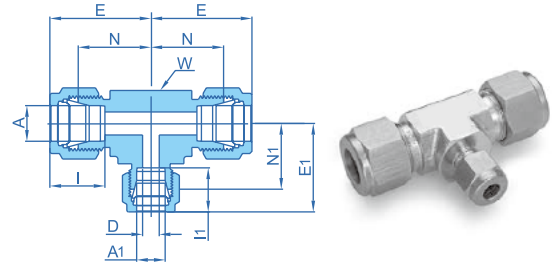

ALL TUBE (METRIC)																			
Ordering Information	A Tube O.D.		A1 Tube O.D.		E		E1		I		I1		D	W Wrench Flat		N		N1	
	mm	mm	mm	mm	mm	mm	mm	mm	mm	mm	mm	mm		inch	mm	mm	mm	mm	mm
SS- VRT- 8M - T6M	8		6		29.9		29.8		16.2		15.3		4.8	5/8	15.9		22.4		22.4
SS- VRT- 10M - T6M	10		6		31.5		31.3		17.2		15.3		4.8	11/16	17.5		23.9		23.9
SS- VRT- 12M - T6M	12		6		36.0		31.8		22.8		15.3		4.8	13/16	20.6		25.9		24.4
SS- VRT- 12M - T10M	12		10		36.0		33.5		22.8		17.2		7.9	13/16	20.6		25.9		25.9
SS- VRT- 14M - T10M	14		10		38.8		36.3		24.4		17.2		7.9	15/16	23.8		28.7		28.7

ALL TUBE (INCH)																					
Ordering Information	A Tube O.D.		A1 Tube O.D.		E		E1		I		I1		D	W Wrench Flat		N		N1			
	inch	mm	inch	mm	inch	mm	inch	mm	inch	mm	inch	mm		inch	mm	inch	mm	inch	mm	inch	mm
SS- VRT - 04 - T02	1/4	6.35	1/8	3.17	1.06	26.9	1.03	26.2	.60	15.2	.50	12.7	.09	2.28	1/2	12.7	.77	19.6	.77	19.6	
SS- VRT - 06 - T04	3/8	9.52	1/4	6.35	1.20	30.5	1.14	29.0	.66	16.8	.60	15.2	.19	4.82	5/8	15.9	.91	23.1	.85	21.6	
SS- VRT - 08 - T04	1/2	12.70	1/4	6.35	1.42	36.1	1.25	31.8	.90	22.9	.60	15.2	.19	4.82	13/16	20.6	1.02	25.9	.96	24.4	
SS- VRT - 08 - T06	1/2	12.70	3/8	9.52	1.42	36.1	1.31	33.3	.90	22.9	.66	16.8	.28	7.11	13/16	20.6	1.02	25.9	1.02	25.9	
SS- VRT - 10 - T06	5/8	15.88	3/8	9.52	1.53	38.9	1.42	36.1	.96	24.4	.66	16.8	.28	7.11	15/16	23.8	1.13	28.7	1.13	28.7	
SS- VRT - 12 - T04	3/4	19.05	1/4	6.35	1.57	39.9	1.46	37.1	.96	24.4	.60	15.2	.19	4.82	1 1/16	27.0	1.17	29.7	1.17	29.7	
SS- VRT - 12 - T06	3/4	19.05	3/8	9.52	1.57	39.9	1.46	37.1	.96	24.4	.66	16.8	.28	7.11	1 1/16	27.0	1.17	29.7	1.17	29.7	
SS- VRT - 12 - T08	3/4	19.05	1/2	12.70	1.57	39.9	1.57	39.9	.96	24.4	.90	22.9	.41	10.41	1 1/16	27.0	1.17	29.7	1.17	29.7	

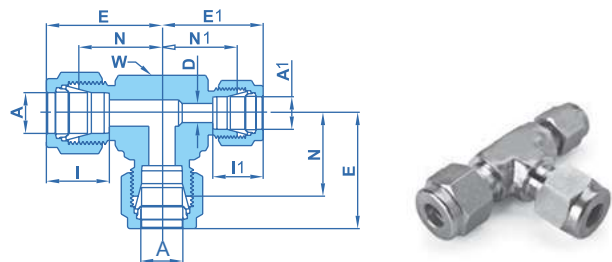

ALL TUBE (INCH)																					
Ordering Information	A Tube O.D.		A1 Tube O.D.		E		E1		I		I1		D	W Wrench Flat		N		N1			
	inch	mm	inch	mm	inch	mm	inch	mm	inch	mm	inch	mm		inch	mm	inch	mm	inch	mm	inch	mm
SS- VRT - 04 - 02 - T04	1/4	6.35	1/8	3.17	1.06	26.9	1.03	26.2	.60	15.2	.50	12.7	.09	2.28	1/2	12.7	.77	19.6	.77	19.6	
SS- VRT - 06 - 04 - T06	3/8	9.25	1/4	6.35	1.20	30.5	1.14	29.0	.66	16.8	.60	15.2	.19	4.82	5/8	15.9	.91	23.1	.85	21.6	
SS- VRT - 08 - 04 - T08	1/2	12.7	1/4	6.35	1.42	36.1	1.31	33.3	.90	22.9	.60	15.2	.19	4.82	13/16	20.6	1.02	25.9	1.02	25.9	
SS- VRT - 08 - 06 - T08	1/2	12.7	3/8	9.52	1.42	36.1	1.31	33.3	.90	22.9	.66	16.8	.28	7.11	13/16	20.6	1.02	25.9	1.02	25.9	
SS- VRT - 12 - 06 - T12	3/4	19.05	3/8	9.52	1.57	39.9	1.46	37.1	.96	24.4	.66	16.8	.28	7.11	1 1/16	27.0	1.17	29.7	1.17	29.7	

# Tube Fittings / Zweiklemmring Verschraubung

## VBU Series

### BULKHEAD UNION

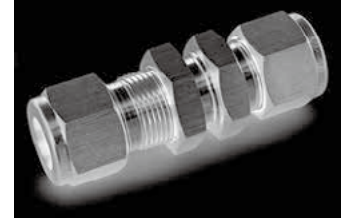
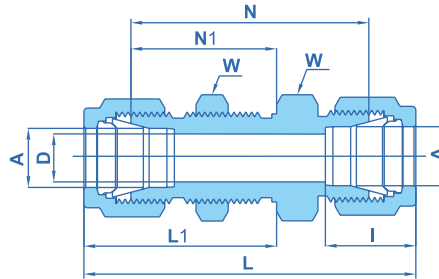

TUBE (METRIC) TO TUBE (METRIC)																	
Ordering Information	A Tube O.D.		D		W Hex. Flat	N		N1		L	L1	I		Panel hole drill size		Max. Panel thickness	
	mm	mm	mm	mm	mm	mm	mm	mm	mm	mm	mm	mm	mm	mm	mm	mm	
SS- VBU - 3M	3	2.4	14	38.1	24.6	51.3	31.2	12.9	8.30	12.7							
SS- VBU - 4M	4	2.4	14	40.4	25.4	53.6	32.0	13.7	9.90	12.7							
SS- VBU - 6M	6	4.8	16	42.9	26.2	57.7	33.6	15.3	11.50	10.2							
SS- VBU - 8M	8	6.4	18	46.0	28.6	61.0	36.1	16.2	13.10	11.2							
SS- VBU - 10M	10	7.9	22	48.5	29.4	63.7	37.0	17.2	16.25	11.2							
SS- VBU - 12M	12	9.5	24	50.8	31.8	71.0	41.9	22.8	19.50	12.7							
SS- VBU - 14M	14	11.0	27	52.3	32.5	72.5	42.6	24.4	22.80	12.7							
SS- VBU - 15M	15	11.9	27	52.3	32.5	72.5	42.6	24.4	22.80	12.7							
SS- VBU - 16M	16	12.7	27	52.3	32.5	72.5	42.6	24.4	22.80	12.7							
SS- VBU - 18M	18	15.1	30	58.7	37.3	78.9	47.4	24.4	26.00	16.8							
SS- VBU - 20M	20	15.9	35	64.3	42.9	84.5	53.0	26.0	29.00	19.0							

TUBE (INCH) TO TUBE (INCH)																			
Ordering Information	A Tube O.D.		D		W Hex. Flat	N		N1		L	L1	I		Panel hole drill size		Max. Panel thickness			
	inch	mm	inch	mm	inch	inch	mm	inch	mm	inch	mm	inch	mm	inch	mm	inch	mm		
SS- VBU - 01	1/16	1.58	.05	1.27	5/16	.94	23.88	.53	13.46	1.24	31.5	.68	17.3	.34	8.6	13/64	5.16	.12	3.05
SS- VBU - 02	1/8	3.17	.09	2.28	1/2	1.50	38.10	.97	24.63	2.02	51.30	1.23	31.24	.50	12.7	21/64	8.33	.50	12.70
SS- VBU - 03	3/16	4.76	.12	3.04	9/16	1.59	40.38	1.00	25.40	2.11	53.59	1.26	32.00	.54	13.7	25/64	9.92	.50	12.70
SS- VBU - 04	1/4	6.35	.19	4.82	5/8	1.69	42.92	1.03	26.16	2.27	57.65	1.32	33.52	.60	15.2	29/64	11.50	.40	10.16
SS- VBU - 05	5/16	7.93	.25	6.35	11/16	1.81	45.97	1.12	28.44	2.39	60.70	1.41	35.81	.64	16.2	33/64	13.09	.44	11.17
SS- VBU - 06	3/8	9.52	.28	7.11	3/4	1.87	47.5	1.16	29.46	2.45	62.2	1.45	36.83	.66	16.8	37/64	14.68	.44	11.17
SS- VBU - 08	1/2	12.70	.41	10.41	15/16	2.00	50.80	1.25	31.75	2.80	71.12	1.65	41.91	.90	22.9	49/64	19.44	.50	12.70
SS- VBU - 10	5/8	15.87	.50	12.70	1 1/16	2.06	52.32	1.28	32.51	2.86	72.64	1.68	42.67	.96	24.4	57/64	22.62	.50	12.70
SS- VBU - 12	3/4	19.05	.62	15.75	1 3/16	2.31	58.67	1.47	37.33	3.11	78.99	1.87	47.49	.96	24.4	1 1/64	25.79	.66	16.76

## MALE BRANCH TEE

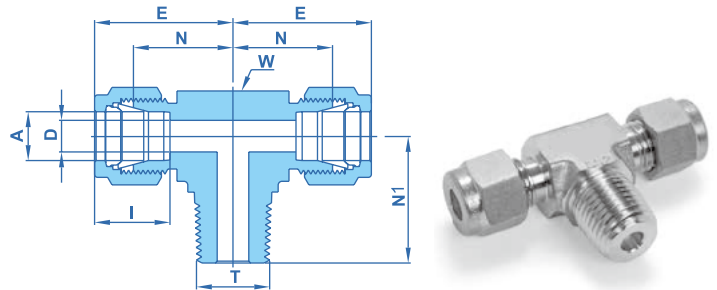

TUBE (METRIC) TO MALE NPT THREAD

Ordering Information	A Tube O.D.		T (NPT)	D		W Wrench Flat		N		E		N1		I	
	mm	inch	inch	mm	inch	mm	inch	mm	inch	mm	inch	mm	inch	mm	inch
SS- VMBT - 6M - M2	6		1/8	4.8		1/2	12.7	19.6		27.0		18.8		15.3	
SS- VMBT - 6M - M4	6		1/4	4.8		1/2	12.7	19.6		27.0		23.4		15.3	
SS- VMBT - 8M - M2	8		1/8	4.8		5/8	15.9	22.4		29.9		20.8		16.2	
SS- VMBT - 8M - M4	8		1/4	6.4		5/8	15.9	22.4		29.9		25.4		16.2	
SS- VMBT - 10M - M4	10		1/4	7.1		13/16	20.6	25.9		33.5		28.2		17.2	
SS- VMBT - 12M - M4	12		1/4	7.1		13/16	20.6	25.9		36.0		28.2		22.8	
SS- VMBT - 12M - M6	12		3/8	9.5		13/16	20.6	25.9		36.0		28.2		22.8	
SS- VMBT - 12M - M8	12		1/2	9.5		13/16	20.6	25.9		36.0		33.0		22.8	
SS- VMBT - 16M - M8	16		1/2	11.9		15/16	23.8	28.7		38.8		35.8		24.4	

TUBE (INCH) TO MALE NPT THREAD

Ordering Information	A Tube O.D.		T (NPT)	D		W Wrench Flat		N		E		N1		I	
	inch	mm	inch	inch	mm	inch	mm	inch	mm	inch	mm	inch	mm	inch	mm
SS- VMBT - 02 - M2	1/8	3.17	1/8	.09	2.28	7/16	11.1	.67	17.02	.93	23.62	.70	17.78	.50	12.7
SS- VMBT - 02 - M4	1/8	3.17	1/4	.09	2.28	1/2	12.7	.71	18.03	.97	24.64	.92	23.37	.50	12.7
SS- VMBT - 03 - M2	3/16	4.76	1/8	.12	3.04	7/16	11.1	.70	17.78	.96	24.38	.70	17.78	.54	13.7
SS- VMBT - 04 - M2	1/4	6.35	1/8	.19	4.82	1/2	12.7	.77	19.56	1.06	26.92	.74	18.80	.60	15.2
SS- VMBT - 04 - M4	1/4	6.35	1/4	.19	4.82	1/2	12.7	.77	19.56	1.06	26.92	.92	23.37	.60	15.2
SS- VMBT - 05 - M2	5/16	7.93	1/8	.19	4.82	5/8	15.9	.88	22.35	1.17	29.71	.82	20.83	.64	16.2
SS- VMBT - 06 - M4	3/8	9.52	1/4	.28	7.11	5/8	15.9	.91	23.11	1.20	30.48	1.00	25.40	.66	16.8
SS- VMBT - 06 - M6	3/8	9.52	3/8	.28	7.11	13/16	20.6	1.02	25.91	1.31	33.27	1.11	28.19	.66	16.8
SS- VMBT - 08 - M6	1/2	12.70	3/8	.38	9.65	13/16	20.6	1.02	25.91	1.42	36.07	1.11	28.19	.90	22.9
SS- VMBT - 08 - M8	1/2	12.70	1/2	.41	10.41	13/16	20.6	1.02	25.91	1.42	36.07	1.30	33.02	.90	22.9
SS- VMBT - 10 - M8	5/8	15.87	1/2	.47	11.94	15/16	23.8	1.13	28.7	1.53	38.86	1.41	35.81	.96	24.4
SS- VMBT - 12 - M12	3/4	19.05	3/4	.62	15.75	1 1/16	27.0	1.17	29.72	1.57	39.88	1.45	36.83	.96	24.4

# Tube Fittings / Zweiklemmring Verschraubung

## VMRT Series

### MALE RUN TEE

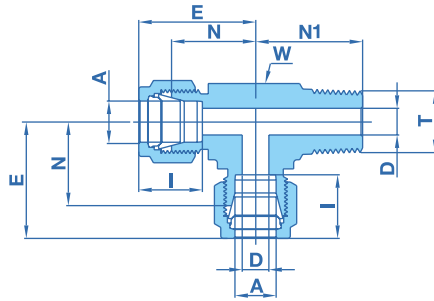

TUBE (METRIC) TO MALE NPT THREAD

Ordering Information	A Tube O.D.		T (NPT)	D		W Wrench Flat		N		E		N1		I	
	mm	inch	inch	mm	inch	mm	mm	mm	mm	mm	mm	mm	mm	mm	mm
SS- VMRT - 6M - M2	6	1/8	1/8	4.8	1/2	12.7	19.6	27.0	18.8	15.3					
SS- VMRT - 6M - M4	6	1/4	1/4	4.8	1/2	12.7	19.6	27.0	23.4	15.3					
SS- VMRT - 8M - M2	8	1/8	1/8	4.8	5/8	15.9	22.4	29.9	20.8	16.2					
SS- VMRT - 8M - M4	8	1/4	1/4	6.4	5/8	15.9	22.4	29.9	25.4	16.2					
SS- VMRT - 10M - M4	10	1/4	1/4	7.1	13/16	20.6	25.9	33.5	28.2	17.2					
SS- VMRT - 12M - M4	12	1/4	1/4	7.1	13/16	20.6	25.9	36.0	28.2	22.8					
SS- VMRT - 12M - M6	12	3/8	3/8	9.5	13/16	20.6	25.9	36.0	28.2	22.8					
SS- VMRT - 12M - M8	12	1/2	1/2	9.5	13/16	20.6	25.9	36.0	33.0	22.8					
SS- VMRT - 16M - M8	16	1/2	1/2	11.9	15/16	23.8	27.9	38.0	35.0	24.4					

TUBE (INCH) TO MALE NPT THREAD

Ordering Information	A Tube O.D.		T (NPT)	D		W Wrench Flat		N		E		N1		I	
	inch	mm	inch	inch	mm	inch	mm	inch	mm	inch	mm	inch	mm	inch	mm
SS- VMRT - 02 - M2	1/8	3.17	1/8	.09	2.28	7/16	11.1	.67	17.02	.93	23.62	.70	17.78	.50	12.7
SS- VMRT - 02 - M4	1/8	3.17	1/4	.09	2.28	1/2	12.7	.71	18.03	.97	24.64	.92	23.40	.50	12.7
SS- VMRT - 03 - M2	3/16	4.76	1/8	.12	3.05	7/16	11.1	.70	17.78	.96	24.38	.70	17.78	.54	13.7
SS- VMRT - 04 - M2	1/4	6.35	1/8	.19	4.82	1/2	12.7	.77	19.56	1.06	26.92	.74	18.8	.60	15.2
SS- VMRT - 04 - M4	1/4	6.35	1/4	.19	4.82	1/2	12.7	.77	19.56	1.06	26.92	.92	23.37	.60	15.2
SS- VMRT - 05 - M2	5/16	7.93	1/8	.19	4.82	5/8	15.9	.88	22.35	1.17	29.71	.82	20.83	.64	16.2
SS- VMRT - 06 - M4	3/8	9.52	1/4	.28	7.11	5/8	15.9	.91	23.11	1.20	30.48	1.00	25.40	.66	16.8
SS- VMRT - 06 - M6	3/8	9.52	3/8	.28	7.11	13/16	20.6	1.02	25.91	1.31	33.27	1.11	28.19	.66	16.8
SS- VMRT - 08 - M6	1/2	12.70	3/8	.38	9.5	13/16	20.6	1.02	25.91	1.42	36.07	1.11	28.19	.90	22.9
SS- VMRT - 08 - M8	1/2	12.70	1/2	.41	10.41	13/16	20.6	1.02	25.91	1.42	36.07	1.30	33.00	.90	22.9
SS- VMRT - 10 - M8	5/8	15.87	1/2	.47	11.94	15/16	23.8	1.10	27.94	1.50	38.1	1.38	35.05	.96	24.4
SS- VMRT - 12 - M12	3/4	19.05	3/4	.62	15.75	1 1/16	27.0	1.17	29.72	1.57	39.88	1.45	36.83	.96	24.4

## FEMALE BRANCH TEE

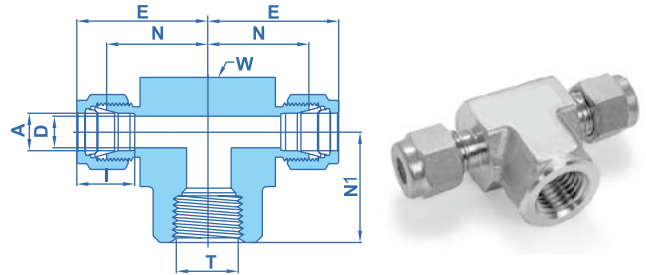

TUBE (METRIC) TO FEMALE NPT THREAD

Ordering Information	A Tube O.D.		T (NPT)	D		W Wrench Flat		N		E		N1		I	
	mm	inch	inch	mm	inch	mm	mm	mm	mm	mm	mm	mm	mm	mm	mm
SS- VFBT - 6M - F2	6		1/8	4.8	5/8	15.9	19.6	27.0	19.0	15.3					
SS- VFBT - 6M - F4	6		1/4	4.8	13/16	20.6	22.4	29.8	22.4	15.3					
SS- VFBT - 8M - F2	8		1/8	6.4	5/8	15.9	22.4	29.9	19.0	16.2					
SS- VFBT - 8M - F4	8		1/4	6.4	13/16	20.6	23.1	30.6	22.4	16.2					
SS- VFBT - 10M - F4	10		1/4	7.9	13/16	20.6	25.9	33.5	22.4	17.2					
SS- VFBT - 10M - F6	10		3/8	7.9	15/16	23.8	25.9	33.5	22.4	17.2					
SS- VFBT - 12M - F4	12		1/4	9.5	13/16	20.6	25.9	36.0	22.4	22.8					
SS- VFBT - 12M - F6	12		3/8	9.5	15/16	23.8	25.9	36.0	22.4	22.8					
SS- VFBT - 12M - F8	12		1/2	9.5	1 1/16	27.0	28.7	38.8	28.4	22.8					
SS- VFBT - 16M - F8	16		1/2	12.7	1 1/16	27.0	28.7	38.8	28.4	24.4					

TUBE (INCH) TO FEMALE NPT THREAD

Ordering Information	A Tube O.D.		T (NPT)	D		W Wrench Flat		N		E		N1		I	
	inch	mm	inch	inch	mm	inch	mm	inch	mm	inch	mm	inch	mm	inch	mm
SS- VFBT - 02 - F2	1/8	3.17	1/8	.09	2.28	5/8	15.9	.70	18.00	.97	24.64	.75	19.05	.50	12.7
SS- VFBT - 04 - F2	1/4	6.35	1/8	.19	4.82	5/8	15.9	.77	19.56	1.06	26.96	.75	19.05	.60	15.2
SS- VFBT - 04 - F4	1/4	6.35	1/4	.19	4.82	13/16	20.6	.88	22.35	1.17	29.71	.88	22.35	.60	15.2
SS- VFBT - 06 - F4	3/8	9.52	1/4	.28	7.11	13/16	20.6	.94	23.88	1.23	31.24	.88	22.35	.66	16.8
SS- VFBT - 06 - F6	3/8	9.52	3/8	.28	7.11	15/16	23.8	1.02	25.90	1.31	33.27	.88	22.35	.66	16.8
SS- VFBT - 06 - F8	3/8	9.52	1/2	.28	7.11	1 1/16	27.0	1.13	28.70	1.42	36.07	1.12	28.45	.66	16.8
SS- VFBT - 08 - F4	1/2	12.70	1/4	.41	10.41	13/16	20.6	1.02	25.90	1.42	36.07	.88	22.35	.90	22.9
SS- VFBT - 08 - F6	1/2	12.70	3/8	.41	10.41	15/16	23.8	1.02	25.90	1.42	36.07	.88	22.35	.90	22.9
SS- VFBT - 08 - F8	1/2	12.70	1/2	.41	10.41	1 1/16	27.0	1.13	28.70	1.53	38.86	1.12	28.45	.90	22.9
SS- VFBT - 10 - F8	5/8	15.87	1/2	.50	12.70	1 1/16	27.0	1.13	28.70	1.53	38.86	1.12	28.44	.96	24.4
SS- VFBT - 12 - F12	3/4	19.05	3/4	.62	15.74	1 3/8	34.9	1.36	34.50	1.76	44.70	1.25	31.75	.96	24.4



# Tube Fittings / Zweiklemmring Verschraubung

## VFRT Series

### FEMALE RUN TEE

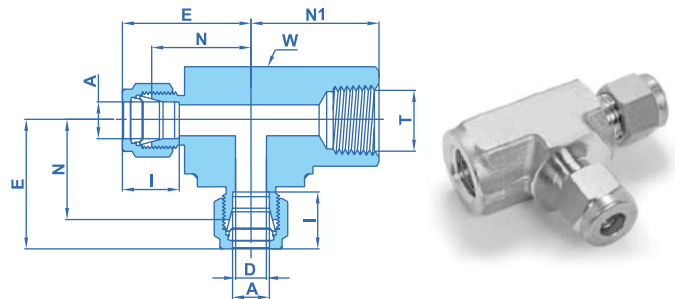

TUBE (METRIC) TO FEMALE NPT THREAD

Ordering Information	A		D	W Wrench Flat		N	E	N1	I
	mm	(NPT)		inch	mm				
SS- VFRT - 6M - F2	6	1/8	4.8	5/8	15.9	19.6	27.0	19.0	15.3
SS- VFRT - 6M - F4	6	1/4	4.8	13/16	20.6	22.4	29.8	22.4	15.3
SS- VFRT - 8M - F2	8	1/8	6.4	5/8	15.9	22.4	29.9	22.4	16.2
SS- VFRT - 8M - F4	8	1/4	6.4	13/16	20.6	23.1	30.6	26.0	16.2
SS- VFRT - 10M - F4	10	1/4	7.9	13/16	20.6	25.9	33.5	22.4	17.2
SS- VFRT - 12M - F4	12	1/4	9.5	13/16	20.6	25.9	36.0	22.4	22.8
SS- VFRT - 12M - F6	12	3/8	9.5	15/16	23.8	25.9	36.0	22.4	22.8
SS- VFRT - 12M - F8	12	1/2	9.5	1 1/16	27.0	29.7	39.8	28.4	22.8
SS- VFRT - 16M - F8	16	1/2	12.7	1 1/16	27.0	29.7	39.8	28.4	24.4

TUBE (INCH) TO FEMALE NPT THREAD

Ordering Information	A Tube O.D.		T (NPT)	D		W Wrench Flat		N		E		N1		I	
	inch	mm		inch	mm	inch	mm	inch	mm	inch	mm	inch	mm	inch	mm
SS- VFRT - 02 - F2	1/8	3.17	1/8	.09	2.28	5/8	15.9	.71	18.00	.97	24.63	.75	19.05	.50	12.7
SS- VFRT - 04 - F2	1/4	6.35	1/8	.19	4.82	5/8	15.9	.77	19.55	1.06	26.92	.75	19.05	.60	15.2
SS- VFRT - 04 - F4	1/4	6.35	1/4	.19	4.82	13/16	20.6	.88	22.35	1.17	29.71	.88	22.35	.60	15.2
SS- VFRT - 06 - F4	3/8	9.52	1/4	.28	7.11	13/16	20.6	.94	23.87	1.23	31.24	.88	22.35	.66	16.8
SS- VFRT - 08 - F6	1/2	12.70	3/8	.41	10.41	15/16	23.8	1.02	25.9	1.42	36.07	.88	22.35	.90	22.9
SS- VFRT - 08 - F8	1/2	12.70	1/2	.41	10.41	1 1/16	27.0	1.17	29.72	1.57	39.88	1.12	28.45	.90	22.9
SS- VFRT - 12 - F12	3/4	19.05	3/4	.62	15.75	1 3/8	34.9	1.36	34.54	1.76	44.70	1.25	31.75	.96	24.4

## UNION CROSS

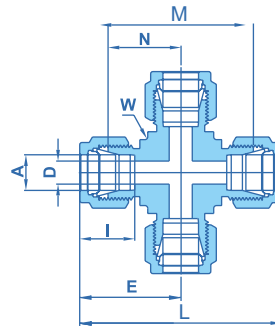

### ALL TUBES (METRIC)

Ordering Information	A Tube O.D.		D		W Wrench Flat		N		E		M		L		I	
	mm	mm	mm	mm	inch	mm	mm	mm	mm	mm	mm	mm	mm	mm	mm	
SS- VUC - 3M	3	2.4	3/8	9.5	15.7	22.3	31.5	44.7	12.9							
SS- VUC - 6M	6	4.8	1/2	12.7	19.6	27.0	39.1	53.9	15.3							
SS- VUC - 8M	8	6.4	5/8	15.9	22.4	29.9	44.7	59.7	16.2							
SS- VUC - 10M	10	7.9	13/16	20.6	25.9	33.5	51.8	67.0	17.2							
SS- VUC - 12M	12	9.5	13/16	20.6	25.9	36.0	51.8	72.0	22.8							
SS- VUC - 16M	16	12.7	15/16	23.8	26.9	37.0	53.8	74.0	24.4							
SS- VUC - 18M	18	15.1	1 1/16	27.0	28.2	38.3	56.4	76.6	24.4							
SS- VUC - 20M	20	15.9	1 3/8	34.9	34.5	44.6	69.0	89.3	26.0							
SS- VUC - 22M	22	18.3	1 3/8	34.9	34.6	44.7	69.1	89.4	26.0							
SS- VUC - 25M	25	21.8	1 3/8	34.9	36.8	49.1	73.7	98.3	31.3							

### ALL TUBES (INCH)

Ordering Information	A Tube O.D.		D		W Wrench Flat		N		E		M		L		I	
	inch	mm	inch	mm	inch	mm	inch	mm	inch	mm	inch	mm	inch	mm	inch	mm
SS- VUC - 02	1/8	3.17	.09	2.28	3/8	9.5	.62	15.74	.88	22.35	1.24	31.48	1.76	44.70	.50	12.7
SS- VUC - 04	1/4	6.35	.19	4.82	1/2	12.7	.77	19.56	1.06	26.92	1.54	39.12	2.12	53.84	.60	15.2
SS- VUC - 05	5/16	7.93	.25	6.35	5/8	15.9	.88	22.35	1.17	29.71	1.76	44.70	2.34	59.42	.64	16.2
SS- VUC - 06	3/8	9.52	.28	7.11	5/8	15.9	.91	23.11	1.20	30.48	1.82	46.22	2.40	60.96	.66	16.8
SS- VUC - 08	1/2	12.70	.41	10.41	13/16	20.6	1.02	25.9	1.42	36.07	2.04	51.80	2.84	72.14	.90	22.9
SS- VUC - 12	3/4	19.05	.62	15.74	1 1/16	27.0	1.17	29.72	1.57	39.88	2.34	59.44	3.14	79.76	.96	24.4

# Tube Fittings / Zweiklemmring Verschraubung

## VC Series

### CAP

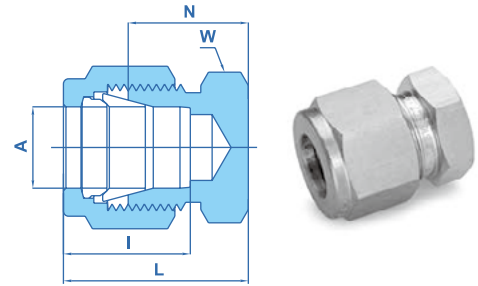

#### CAPPING END OF TUBE (METRIC)

Ordering Information	A Tube O.D.		W Hex. Flat	N		L		I	
	mm	mm	mm	mm	mm	mm	mm	mm	mm
SS- VC - 2M	2		12	13.5		20.1		12.9	
SS- VC - 3M	3		12	13.5		20.1		12.9	
SS- VC - 4M	4		12	14.7		21.3		13.7	
SS- VC - 6M	6		14	15.7		23.1		15.3	
SS- VC - 8M	8		15	17.0		24.5		16.2	
SS- VC - 10M	10		18	19.0		26.6		17.2	
SS- VC - 12M	12		22	19.0		29.1		22.8	
SS- VC - 14M	14		24	19.8		29.9		24.4	
SS- VC - 15M	15		24	19.8		29.9		24.4	
SS- VC - 16M	16		24	19.8		29.9		24.4	
SS- VC - 18M	18		27	21.3		31.4		24.4	
SS- VC - 20M	20		30	23.9		34.0		26.0	
SS- VC - 22M	22		30	23.9		34.0		26.0	

#### CAPPING END OF TUBE (INCH)

Ordering Information	A Tube O.D.		W Hex. Flat	N		L		I	
	inch	mm	inch	inch	mm	inch	mm	inch	mm
SS- VC - 01	1/16	1.58	5/16	.44	11.17	.59	14.98	.34	8.6
SS- VC - 02	1/8	3.17	7/16	.53	13.46	.79	20.06	.50	12.7
SS- VC - 04	1/4	6.35	1/2	.63	16.00	.92	23.37	.60	15.2
SS- VC - 06	3/8	9.52	5/8	.72	18.28	1.01	26.65	.66	16.8
SS- VC - 08	1/2	12.70	13/16	.75	19.05	1.15	29.21	.90	22.9
SS- VC - 10	5/8	15.87	15/16	.78	19.81	1.18	29.97	.96	24.4
SS- VC - 12	3/4	19.05	1 1/16	.84	21.33	1.24	31.49	.96	24.4
SS- VC - 14	7/8	22.22	1 3/16	.94	23.88	1.34	34.04	1.02	25.9

## NUT

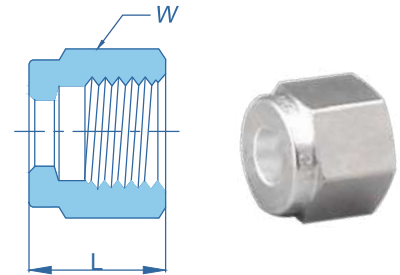

METRIC					
Ordering Information	Tube O.D.		W Hex. Flat	L	
	inch	mm		inch	mm
SS- VN - 3M	1/8	3	1/2	0.47	11.9
SS- VN - 6M	1/4	6	5/8	0.50	12.7
SS- VN - 8M	3/8	8	3/4	0.56	13.5
SS- VN - 10M	1/2	10	7/8	0.69	15.1
SS- VN - 16M	3/4	16	1 1/8	0.69	17.4
SS- VN - 18M	7/8	18	1 1/4	0.69	17.4
SS- VN - 20M	1	20	1 1/2	0.81	17.4

INCH					
Ordering Information	A Tube O.D.		W Hex. Flat	L	
	inch	mm		inch	mm
SS- VN - 02	1/8	3.17	7/16	0.47	11.94
SS- VN - 04	1/4	6.35	9/16	0.50	12.70
SS- VN - 06	3/8	9.52	11/16	0.56	14.22
SS- VN - 08	1/2	12.70	7/8	0.69	17.53
SS- VN - 12	3/4	19.05	1 1/8	0.69	17.53
SS- VN - 16	1	25.40	1 1/2	0.81	20.57

## PLUG

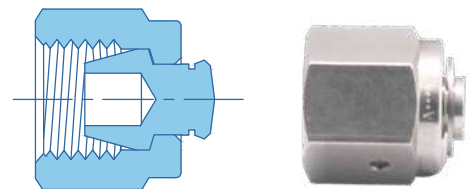

METRIC	
Ordering Information	A Tube O.D.
	mm
SS- VP - 3M	3
SS- VP - 6M	6
SS- VP - 8M	8
SS- VP - 10M	10
SS- VP - 16M	12
SS- VP - 18M	16
SS- VP - 20M	20

INCH		
Ordering Information	A Tube O.D.	
	inch	mm
SS- VP - 02	1/8	3.17
SS- VP - 04	1/4	6.35
SS- VP - 06	3/8	9.52
SS- VP - 08	1/2	12.70
SS- VP - 12	3/4	19.05
SS- VP - 16	1	25.40

### FRONT FERRULE

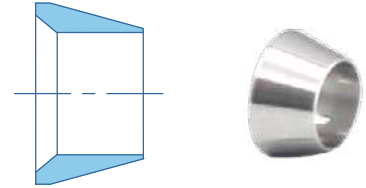

FRONT FERRULE(METRIC)	
Ordering Information	Tube O.D.
	mm
SS- VFF - 3M	3
SS- VFF - 6M	6
SS- VFF - 8M	8
SS- VFF - 10M	10
SS- VFF - 12M	12
SS- VFF - 16M	16
SS- VFF - 18M	18
SS- VFF - 20M	20

FRONT FERRULE(INCH)		
Ordering Information	Tube O.D.	
	inch	mm
SS- VFF - 02	1/8	3.17
SS- VFF - 04	1/4	6.35
SS- VFF - 06	3/8	9.52
SS- VFF - 08	1/2	12.70
SS- VFF - 12	3/4	19.70
SS- VFF - 16	1	25.40

### BACK FERRULE

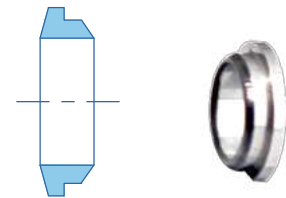

BACK FERRULE(METRIC)	
Ordering Information	Tube O.D.
	mm
SS- VBF - 3M	3
SS- VBF - 6M	6
SS- VBF - 8M	8
SS- VBF - 10M	10
SS- VBF - 12M	12
SS- VBF - 16M	16
SS- VBF - 18M	18
SS- VBF - 20M	20

BACK FERRULE(INCH)		
Ordering Information	Tube O.D.	
	inch	mm
SS- VBF - 02	1/8	3.17
SS- VBF - 04	1/4	6.35
SS- VBF - 06	3/8	9.52
SS- VBF - 08	1/2	12.70
SS- VBF - 12	3/4	19.70
SS- VBF - 16	1	25.40

# Conversion Factors Umrechnungstabellen

## Pressure

	atm	bar	ft of H <sub>2</sub> O	in of hg	in of H <sub>2</sub> O	kg/cm <sup>2</sup>	kPa	mm of Hg	PSI
MULTIPLY BY									
atm	....	1.01325	33.932	29.921	407.1827	1.0332	101.3171	760	14.696
bar	0.98692	....	33.4883	29.530	401.8596	1.019716	100	750.062	14.50368
ft of H <sub>2</sub> O	0.02947	0.029891	....	0.882646	12	0.03048	2.9890	22.4198	0.433107
in of hg	0.03342	0.033864	1.1340	....	13.6	0.034532	3.376895	25.4	0.49115
in of H <sub>2</sub> O	0.00246	0.002499	0.083333	0.073556	....	0.00254	0.0249089	1.86832	0.03609
kg/cm <sup>2</sup>	0.9678	0.980665	32.8084	28.95903	393.7008	....	98.03922	735.5592	14.22334
kPa	0.00987	0.010	0.33456	0.29613	4.01472	0.01020	....	7.5006	0.14504
mm of Hg	0.00132	0.001333	0.044603	0.03937	0.535240	0.001360	0.133322	....	0.019337
PSI	0.06805	0.068948	2.3089	2.0360	27.70851	0.070307	6.89465	51.175	....

## Flow

	cm <sup>3</sup> /min	cm <sup>3</sup> /sec	ft <sup>3</sup> /hr	ft <sup>3</sup> /min	m <sup>3</sup> /hr	m <sup>3</sup> /min	L/hr	Lpm
MULTIPLY BY								
cm <sup>3</sup> /min	....	0.0166667	0.0021189	0.0000353	0.00006	0.000001	0.06	0.001
cm <sup>3</sup> /sec	60	....	0.1271340	0.0021189	0.0036	0.00006	3.6	0.06
ft <sup>3</sup> /hr	471.9474	7.865790	....	0.0166667	0.0283168	0.0004719	28.31685	0.4719474
ft <sup>3</sup> /min	28.316.85	471.9474	60	....	1.699008	0.0283168	1699.008	28.31686
m <sup>3</sup> /hr	16.666.67	277.7778	35.31467	0.5885777	....	0.0166667	1000	16.66667
m <sup>3</sup> /min	1,000,000	16.666.67	2118.876	35.31467	60	....	60,000	1000
L/hr	16.66667	0.2777778	0.0353147	0.0005885	0.001	0.0000167	....	0.0166667
Lpm	1000	16.66667	2.118876	0.0353147	0.06	0.001	60	....

## Density

	gms/cm <sup>3</sup>	kg/m <sup>3</sup>	lbs/ft <sup>3</sup>	lbs/in <sup>3</sup>	lbs/U.S. gal
MULTIPLY BY					
gms/cm <sup>3</sup>	....	1000	62.428	0.0361273	8.3454
kg/m <sup>3</sup>	0.001	....	0.062428	3.61273 x 10 <sup>-5</sup>	0.0083454
lbs/ft <sup>3</sup>	0.0160185	16.018463	....	5.78704 x 10 <sup>-4</sup>	0.13368
lbs/in <sup>3</sup>	27.679905	27.679.9	1728	....	231
lbs/U.S. gal	0.1198264	119.8264	7.4805195	0.004329	....

### Key To Material Compatibility

- 1- Satisfactory for use with the intended gas
- 2- Unsatisfactory for use with the intended gas
- 3- Insufficient data available to determine compatibility with the intended gas
- 4- Satisfactory with brass having a low copper content
- 5- Satisfactory with acetylene, however, cylinder gas is dissolved in a solvent (generally acetone) which may be incompatible with these elastomers
- 6- Satisfactory with brass, except where acetylene or acetylides are present
- 7- Generally unsatisfactory, except where specific use conditions have proven acceptable
- 8- Satisfactory below 3000 PSIG (206.9 bar) where gas velocities do not exceed 30 ft./sec.
- 9- Compatibility depends on condition of use

\* For reference only

COMPATIBILITY GUIDE		MATERIALS OF CONSTRUCTION										
		METALS					PLASTICS		ELASTOMERS			
Common Name	Chemical Formula	Brass	Stainless Steel	Aluminum	Zinc	Copper	PCTFE	Teflon®	Viton®	Buna-N	Neoprene	Polyurethane
Acetylene	C <sub>2</sub> H <sub>2</sub>	4	1	3	2	2	1	1	5	5	5	
Air	-	1	1	1	1	1	1	1	1	1	1	1
Allene	C <sub>3</sub> H <sub>4</sub>	1	1	1	3	2	1	1	1	1	1	3
Ammonia	NH <sub>3</sub>	2	1	1	2	2	1	1	2	1	1	2
Argon	Ar	1	1	1	1	1	1	1	1	1	1	1
Arsine	AsH <sub>3</sub>	1	1	7	3	1	1	1	1	1	1	2
Boron Trichloride	BCl <sub>3</sub>	2	1	2	3	1	1	1	3	3	3	3
Boron Trifluoride	BF <sub>3</sub>	1	1	1	3	1	1	1	3	3	3	3
1,3-Butadiene	C <sub>4</sub> H <sub>6</sub>	1	1	1	1	1	1	1	1	2	1	2
Butane	C <sub>4</sub> H <sub>10</sub>	1	1	1	1	1	1	1	1	1	1	1
1-Butene	C <sub>4</sub> H <sub>8</sub>	1	1	1	1	1	1	1	1	1	1	1
cis-2-Butene	C <sub>4</sub> H <sub>8</sub>	1	1	1	1	1	1	1	1	1	1	1
trans-2-Butene	C <sub>4</sub> H <sub>8</sub>	1	1	1	1	1	1	1	1	1	1	1
Carbon Dioxide	CO <sub>2</sub>	1	1	1	1	1	1	1	1	1	1	2
Carbon Monoxide	CO	1	1	1	1	1	1	1	3	1	1	1
Carbonyl Sulfide	COS	1	1	1	3	1	1	1	1	3	3	3
Chlorine	Cl <sub>2</sub>	2	1	2	2	2	1	1	1	2	2	2
Deuterium	D <sub>2</sub>	1	1	1	1	1	1	1	1	1	1	1
Diborane	B <sub>2</sub> H <sub>6</sub>	1	1	2	3	1	1	1	3	3	3	3
Dichlorosilane	H <sub>2</sub> SiCl <sub>2</sub>	3	1	3	3	3	1	1	3	3	3	3
Dimethyl Ether	C <sub>2</sub> H <sub>6</sub> O	1	1	1	1	1	1	1	1	1	1	3
Ethane	C <sub>2</sub> H <sub>6</sub>	1	1	1	1	1	1	1	1	1	1	1
Ethyl Acetylene	C <sub>4</sub> H <sub>6</sub>	3	1	1	3	2	1	1	1	3	1	3
Ethyl Chloride	C <sub>2</sub> H <sub>5</sub> Cl	1	1	2	3	1	1	1	1	1	1	2
Ethylene	C <sub>2</sub> H <sub>4</sub>	1	1	1	1	1	1	1	1	1	1	3
Ethylene Oxide*	C <sub>2</sub> H <sub>4</sub> O	6	1	7	3	2	1	1	2	2	2	2
Ethylene Oxide/Carbon Dioxide Mixtures*	R <sub>3</sub>	1	3	3	2	1	1	2	2	2	2	
Ethylene Oxide/Halocarbon Mixtures*	R <sub>3</sub>	1	3	3	2	1	1	2	2	2	2	
Ethylene Oxide/HCFC-124	R <sub>3</sub>	1	3	3	2	1	1	2	2	2	2	
Halocarbon 11	CCl <sub>3</sub> F	1	1	7	3	1	1	1	1	1	2	2
Halocarbon 12	CCl <sub>2</sub> F <sub>2</sub>	1	1	7	3	1	1	1	1	1	1	1
Halocarbon 13	CClF <sub>3</sub>	1	1	7	3	1	1	1	1	1	1	1
Halocarbon 13B1	CBF <sub>3</sub>	1	1	7	3	1	1	1	1	1	1	1
Halocarbon 14	CF <sub>4</sub>	1	1	7	3	1	1	1	1	1	1	1

COMPATIBILITY GUIDE		MATERIALS OF CONSTRUCTION										
		METALS					PLASTICS		ELASTOMERS			
Common Name	Chemical Formula	Brass	Stainless Steel	Aluminum	Z3nc	Copper	PCTFE	Teflon <sup>®</sup>	Viton <sup>®</sup>	Buna-N	Neoprene	Polyurethane
Halocarbon 21	CHCl <sub>2</sub> F	1	1	7	3	1	1	1	2	2	1	1
Halocarbon 22	CHClF <sub>2</sub>	1	1	7	3	1	1	1	2	2	1	2
Halocarbon 23	CHF <sub>3</sub>	1	1	7	3	1	1	1	3	3	3	1
Halocarbon 113	CCl <sub>2</sub> FCClF <sub>2</sub>	1	1	7	2	1	1	1	1	1	1	1
Halocarbon 114	C <sub>2</sub> Cl <sub>2</sub> F <sub>4</sub>	1	1	7	3	1	1	1	1	1	1	1
Halocarbon 115	C <sub>2</sub> ClF <sub>5</sub>	1	1	7	3	1	1	1	1	1	1	1
Halocarbon 116	C <sub>2</sub> F <sub>6</sub>	1	1	7	3	1	1	1	3	3	3	1
Halocarbon 142B	C <sub>2</sub> H <sub>3</sub> ClF <sub>2</sub>	1	1	7	3	1	1	1	2	1	1	1
Halocarbon 152A	C <sub>2</sub> H <sub>4</sub> F <sub>2</sub>	1	1	7	3	1	1	1	2	1	1	1
Halocarbon C-318	C <sub>2</sub> F <sub>8</sub>	1	1	7	3	3	1	1	1	1	1	1
Halocarbon 502	CHClF <sub>2</sub> /CClF <sub>2</sub> -CF <sub>3</sub>	3	1	7	3	3	1	1	1	1	1	1
Halocarbon 1132A	C <sub>2</sub> H <sub>2</sub> F <sub>2</sub>	1	1	7	3	1	3	1	3	3	3	1
Helium	He	1	1	1	1	1	1	1	1	1	1	1
Hydrogen	H <sub>2</sub>	1	1	1	1	1	1	1	1	1	1	1
Hydrogen Chloride	HCl	2	1	2	2	2	1	1	1	2	2	2
Hydrogen Sulfide	H <sub>2</sub> S	2	1	1	3	3	1	1	2	1	1	1
Isobutane	C <sub>4</sub> H <sub>10</sub>	1	1	1	1	1	1	1	1	1	1	1
Isobutylene	C <sub>4</sub> H <sub>8</sub>	1	1	1	3	1	1	1	1	1	1	3
Isopentane	C <sub>5</sub> H <sub>12</sub>	1	1	1	1	1	1	1	1	1	1	1
Krypton	Kr	1	1	1	1	1	1	1	1	1	1	1
Methane	CH <sub>4</sub>	1	1	1	1	1	1	1	1	1	1	1
Methyl Chloride	CH <sub>3</sub> Cl	1	1	2	2	1	1	1	1	2	2	2
Methyl Mercaptan	CH <sub>3</sub> SH	1	1	2	3	2	1	1	3	3	1	3
Neon	Ne	1	1	1	1	1	1	1	1	1	1	1
Nitric Oxide	NO	2	1	1	3	1	1	1	3	3	1	3
Nitrogen	N <sub>2</sub>	1	1	1	1	1	1	1	1	1	1	1
Nitrogen Dioxide	NO <sub>2</sub>	3	1	1	3	3	1	1	2	2	2	2
Nitrous Oxide	N <sub>2</sub> O	1	1	1	1	1	1	1	1	1	1	1
Oxygen	O <sub>2</sub>	1	8	7	1	1	1	1	9	9	9	1
Perfluoropropane	C <sub>3</sub> F <sub>8</sub>	1	1	1	3	1	1	1	3	1	1	3
Phosphine	PH <sub>3</sub>	3	1	1	3	3	1	1	3	3	3	3
Phosphorous Pentafluoride	PF <sub>5</sub>	3	1	3	3	3	1	1	3	3	3	3
Propane	C <sub>3</sub> H <sub>8</sub>	1	1	1	1	1	1	1	1	1	1	1
Propylene	C <sub>3</sub> H <sub>6</sub>	1	1	1	1	1	1	1	1	2	2	2
Propylene Oxide	C <sub>3</sub> H <sub>6</sub> O	3	1	3	3	3	1	1	2	2	2	2
Refrigerant Gases	See Halocarbons											
Silane	SiH <sub>4</sub>	1	1	1	3	1	1	1	1	1	1	1
Silicon Tetrachloride	SiCl <sub>4</sub>	3	1	2	3	3	1	1	3	3	3	3
Silicon Tetrafluoride	SiF <sub>4</sub>	1	1	1	3	1	1	1	1	1	1	1
Sulfur Dioxide	SO <sub>2</sub>	2	1	1	2	2	1	1	1	2	2	1
Sulfur Hexafluoride	SF <sub>6</sub>	1	1	1	3	1	1	1	1	1	1	1
Trichlorosilane	HSiCl <sub>3</sub>	3	1	2	3	3	1	1	3	3	3	3
Vinyl Methyl Ether	C <sub>3</sub> H <sub>6</sub> O	1	1	1	3	2	1	1	3	3	3	3
Xenon	Xe	1	1	1	1	1	1	1	1	1	1	1



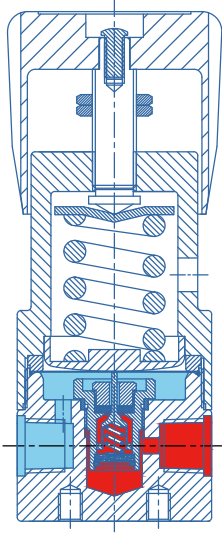

VSR-1E Series

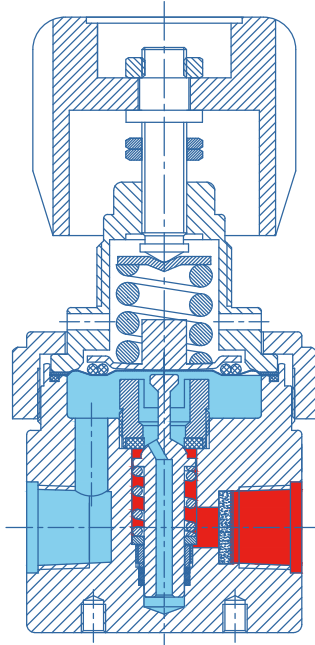

VSR-3 Series

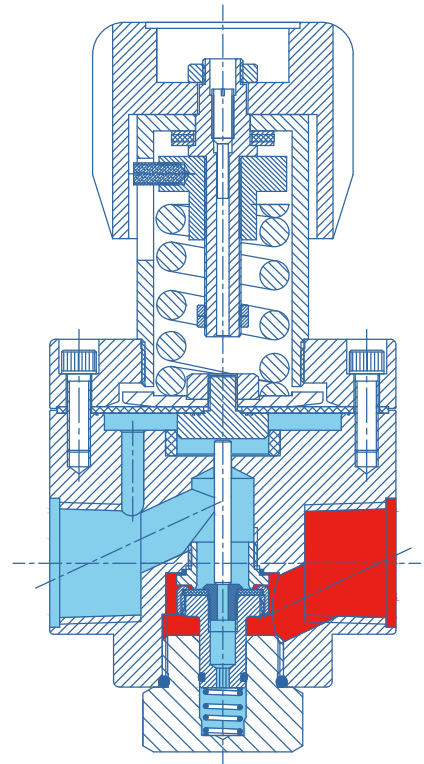

VSR-4 Series

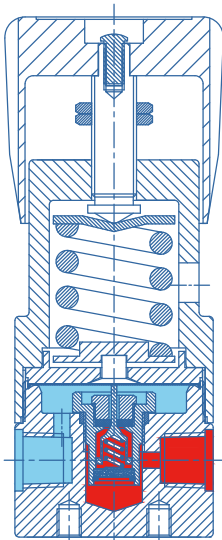

VSR-6E Series

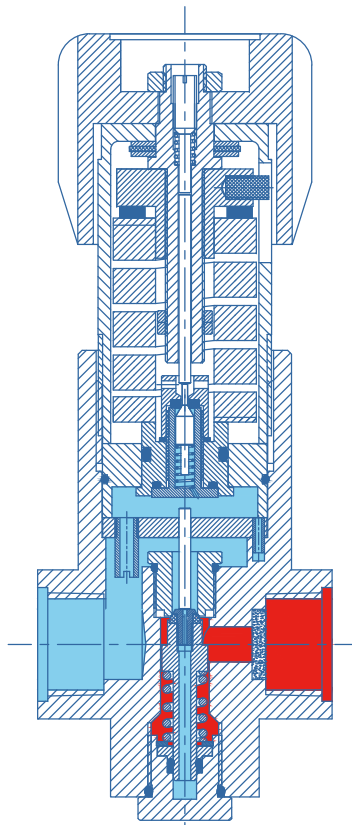

VSR-7 Series

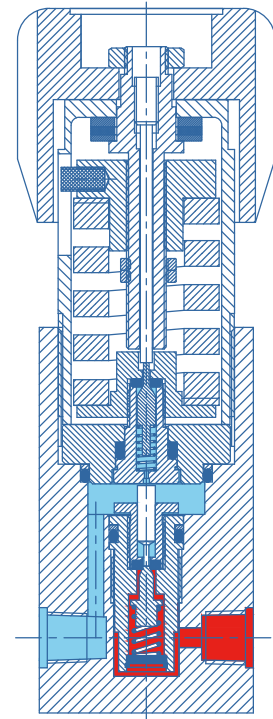

VSR-8 Series

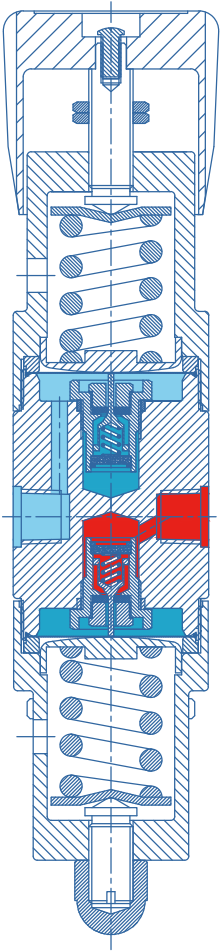

VSR-11E Series

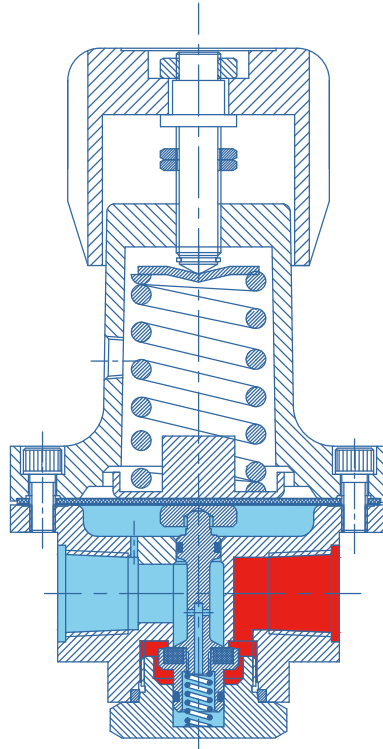

VSR-12L Series

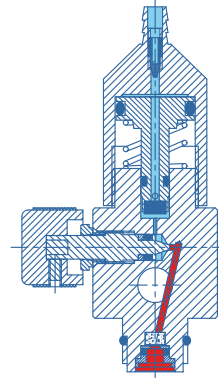

VSR-15 Series

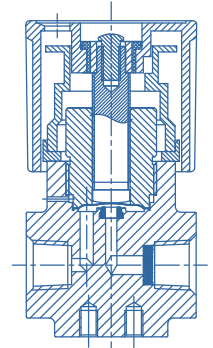

VDV1 Series

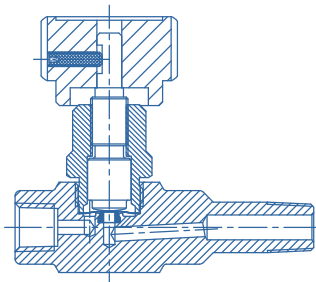

VDV2 Series

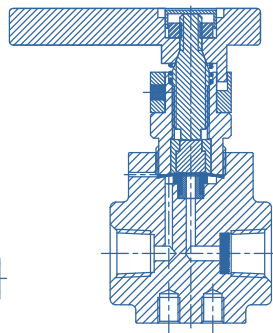

VDV30 Series

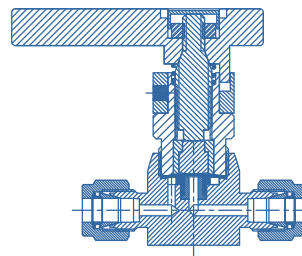

VDV31 Series

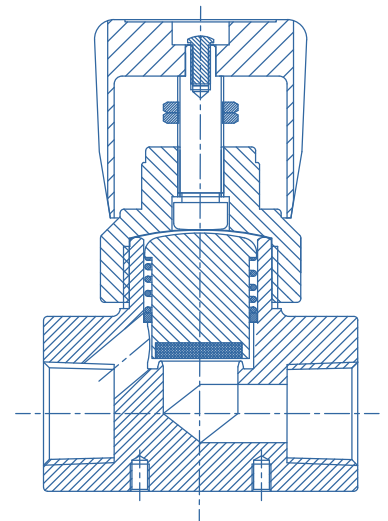

VDV8 Series