

Table Of Contents |

Regulators for General Applications | P1~6

VSR-1000UA Series	p1~2
VSR-1600UA Series	p3~4
VSR-9200UA Series	p5~6

Regulators for UHP Applications | P7~18

VSR-1000UB Series	p7~8
VSR-1000UC Series	p9~10
VSR-1600UB Series	p11~12
VSR-1600UC Series	p13~14
VSR-9200UB Series	p15~16
VSR-9200UC Series	p17~18

Diaphragm Valves for General Applications | P19~24

VDV31UA Series	p19~20
VDV32UA Series	p21~22
VDV33UA Series	p23~24

Diaphragm Valves for UHP Applications | P25~30

VDV31UB Series	p25~26
VDV32UB Series	p27~28
VDV33UB Series	p29~30

VFS face seal fittings | P31~38

VVR Series	p31~38
Glands	p33
Gaskets	p34
Bodies	p35~36
Nuts,Caps,Plugs	p37~38

Micro Weld Fittings | P39~41

VMW Series	p39~41
------------	--------

Cylinder Connections | P42~44

VUC Series	p42~44
------------	--------

Gauges | P45~46

VIGOUR®

Wir bieten Lösungen für Ihre Ideen!
We offer solutions regarding your ideas!

Single Stage Pressure Regulators

VSR-1000UA Series

Product Feature

- Single-stage pressure regulator
- All gas-wetted parts made of stainless steel SS 316L, Hastelloy C276 and PCTFE respectively
- High control outlet pressure accuracy
- Metal-to-metal seal to atmosphere
- Simple outlet pressure limitation by hand-wheel
- 100 % helium-leak-tested
- Cleaned for O₂ service



Dimensions(mm)

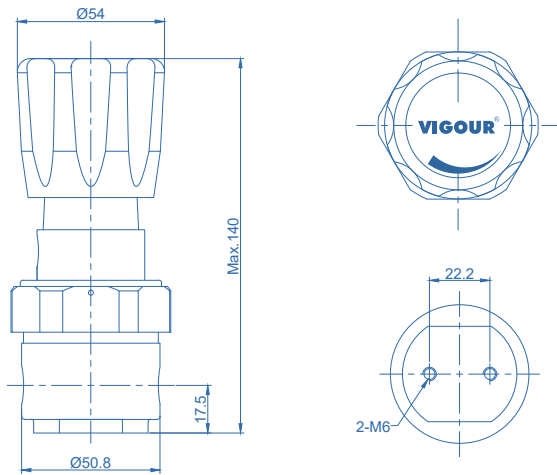

Technical Data

Type	single-stage
Inlet pressure P1	max. 3500 psig
Outlet pressure P2	10/30/60/100/150/200/300/500 psig
Materials	
Body regulator	see ordering info
Valve seat	PCTFE
Diaphragm	Hastelloy® C276
Inlets and Outlets	1/4" NPT(F) and tube fitting
Temperature range	-40°F to +160°F (-40°C to +71°C)
Leak rate (to atmosphere)	1x10 ⁻⁹ mbar l/s He
Flow capacity	Cv=0.09 (Cv=0.15 option)
Weight	approx. 1.25 kg (depending on connections or options)
Supply pressure effect	0.35 psig rise in delivery pressure per 100 psig source pressure drop@Cv=0.09 0.5 psig rise in delivery pressure per 100 psig source pressure drop@Cv=0.15

Flowchart

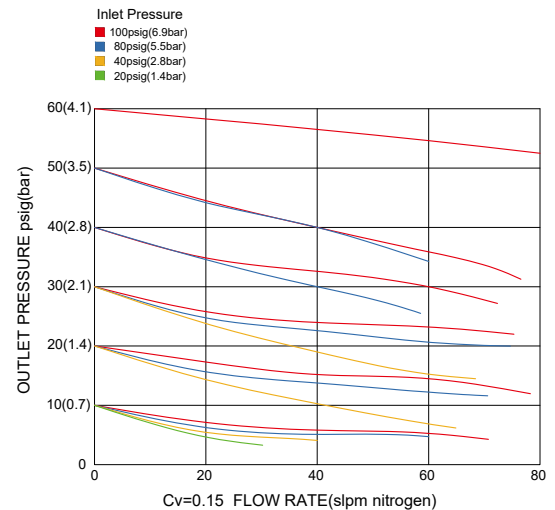
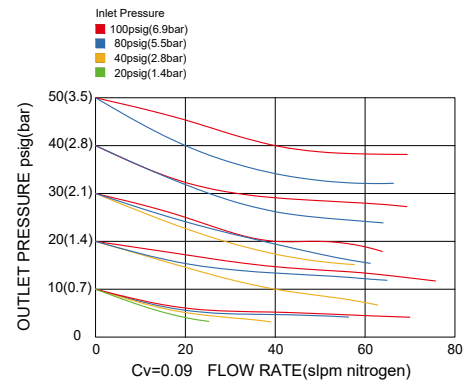
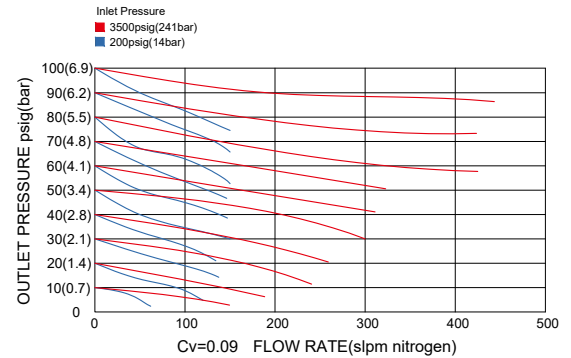

Single Stage Pressure Regulators VSR-1000UA Series

Ordering Information

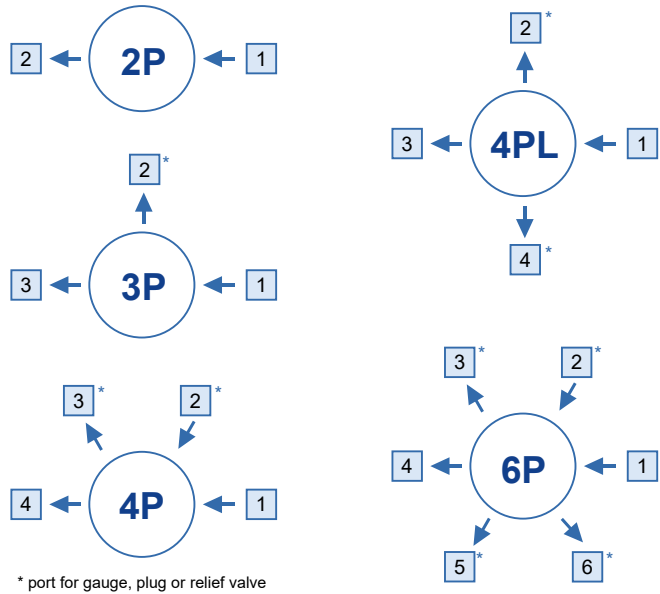

Inlet/Outlet Connection

F4: 1/4" NPT(F) R: relief valve
 O4: 1/4" Tube fitting B: plug
 P: gauge

* Other connection standard, consult factory

Port Selection

VSR - 1000UAPS - 250 - 10 - 6P - 1 - 2 - 3 - 4 - 5 - 6 - HF

Installation

None: surface mount
 P: panel mount

* Panel hole ϕ 36mm

Materials

S: 316L

Inlet Pressure

20: 300 psig
 250: 3500 psig

Port Config

2P: 2 ports
 3P: 3 ports
 4P: 4 ports
 4PL: 4 ports
 6P: 6 ports

Outlet Pressure

V1: Vac to 10 psig
 V2: Vac to 30 psig
 V4: Vac to 60 psig
 V7: Vac to 100psig
 V10: Vac to 150 psig
 1: to 10 psig
 2: to 30 psig
 4: to 60 psig
 7: to 100 psig
 10: to 150 psig
 15: to 200 psig
 20: to 300 psig
 35: to 500 psig

Cv Option

None: Cv=0.09
 HF: Cv=0.15

Ordering Example

VSR - 1000UAS - 250 - 20 - 3P - F4 - P - F4

1 - 2 - 3



Single Stage Pressure Regulators

VSR-1600UA Series

Product Feature

- Single-stage pressure regulator
- All gas-wetted parts made of stainless steel SS 316L, Hastelloy C276 and PCTFE respectively
- High performance, high flow
- High control outlet pressure accuracy
- Simple outlet pressure limitation by hand-wheel
- 100 % helium-leak-tested
- Cleaned for O₂ service

Dimensions(mm)

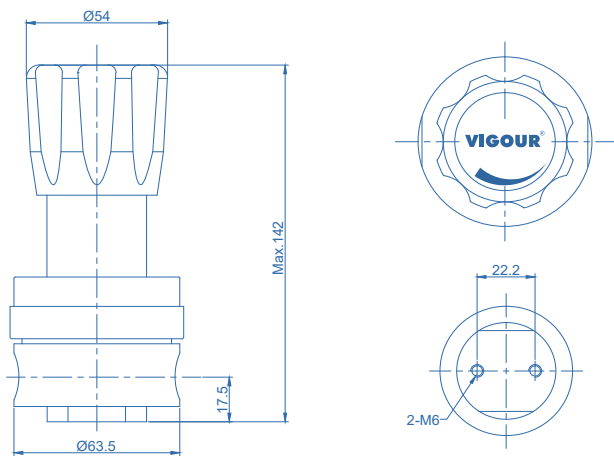

Flowchart

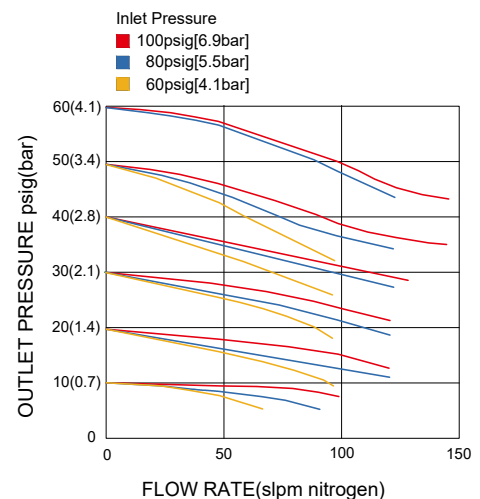
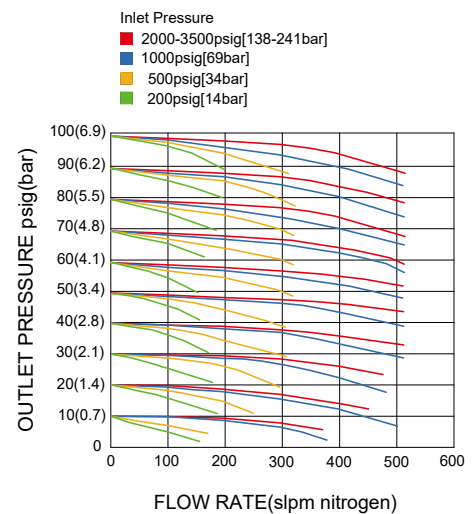

Technical Data

Type	single-stage
Inlet pressure P1	max. 3500 psig
Outlet pressure P2	10/30/60/100 psig
Materials	
Body	see ordering info
Valve seat	PCTFE
Diaphragm	Hastelloy®C276
Inlets and Outlets	1/4" / 3/8" NPT(F) and tube fitting
Bonnet port	1/8" NPT(on panel mount option, bonnet port is not threaded)
Temperature range	-40°F to +160°F (-40°C to +71°C)
Leak rate (to atmosphere)	1x10 ⁻⁹ mbar l/s He
Leak rate (via seat)	1x10 ⁻⁸ mbar l/s He
Flow capacity	Cv=0.13
Weight	approx. 1.5kg (depending on connections and options)
Supply pressure effect	0.25 psig rise in delivery pressure per 100 psig source pressure drop

Single Stage Pressure Regulators VSR-1600UA Series

Ordering Information

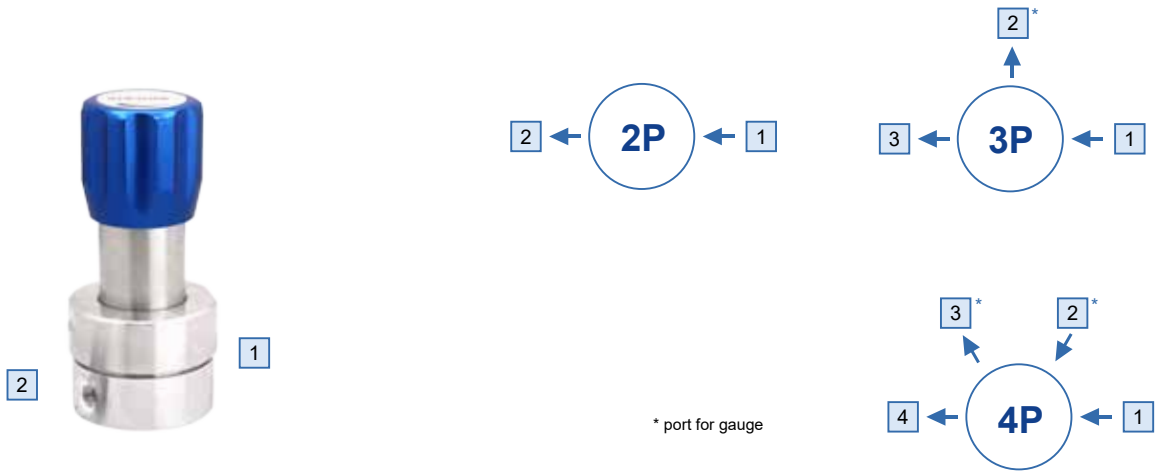

Inlet/outlet Connection

F4: 1/4" NPT(F) 04: 1/4" tube fitting
 F6: 3/8" NPT(F) 06: 3/8" tube fitting
 P: gauge

* Other connection standard, consult factory

Port Selection

VSR - 1600UAPS - 250 - 2 - 4P - 1 - 2 - 3 - 4

Installation
 P: panel mount
 None: bottom mount
 * Panel hole ϕ 36.3mm

Materials
 S: 316L

Inlet Pressure
 7: 100 psig
 250: 3500 psig

Port Config
 2P: 2 ports
 3P: 3 ports
 4P: 4 ports

Outlet Pressure
 1: to 10 psig
 2: to 30 psig
 4: to 60 psig
 7: to 100 psig
 10: to 150 psig

Ordering Example

VSR - 1600UAS - 250 - 10 - 2P - F4 - F4

1 - 2



Single Stage Pressure Regulators

VSR-9200UA Series

Product Feature

- Single-stage pressure regulator
- Minimized internal volume for short purge times
- All gas-wetted parts made of stainless steel SS 316L, Hastelloy C276 and PFA respectively
- Internal connectors for pressure gauges
- High performance, high flow
- High control accuracy
- Metal-to-metal seal to atmosphere
- Simple outlet pressure limitation by hand-wheel
- 100 % helium-leak-tested
- Cleaned for O₂ service



Dimensions(mm)

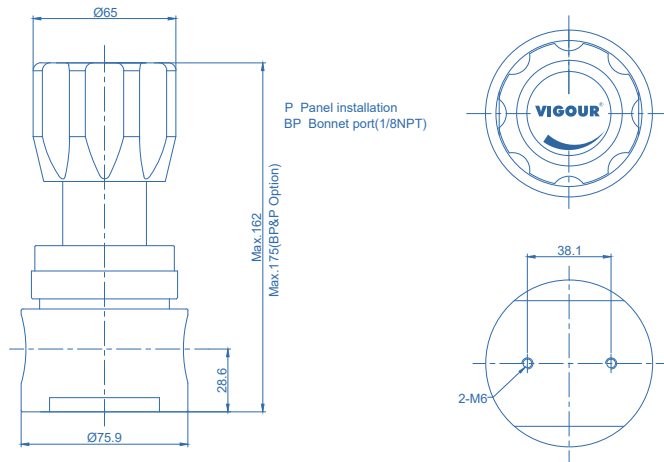

Technical Data

Type	single-stage
Inlet pressure P1	max. 300 psig
Outlet pressure P2	30/60/100/150 psig
Materials	
Body	see ordering info
Valve seat	PFA
Diaphragm	Hastelloy®C276
Inlets and Outlets	3/4" NPT and tube fitting
Bonnet port	1/8" NPT(option)
Temperature range	-40°F to +160°F (-40°C to +71°C)
Leak rate (to atmosphere)	1x10 ⁻⁹ mbar l/s He
Leak rate (via seat)	1x10 ⁻⁸ mbar l/s He
Flow capacity	Cv=1.6
Weight	approx.2.68kg (depending on connections and options)
Supply pressure effect	7 psig rise in delivery pressure per 100 psig source pressure drop

Flowchart

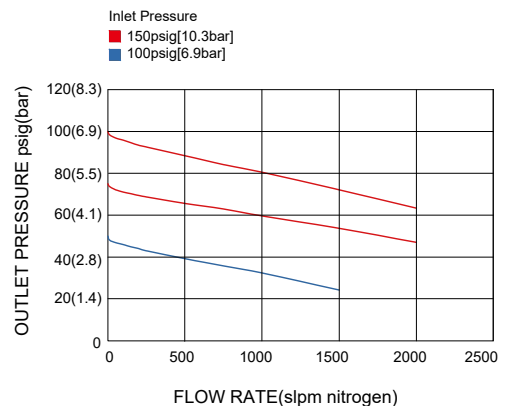

Single Stage Pressure Regulators VSR-9200UA Series

Ordering Information

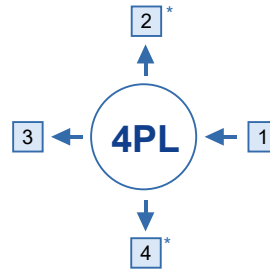

* port for gauge

Inlet/Outlet Connection

F4: 1/4" NPT(F)

P: gauge

F12: 3/4" NPT(F)

B: plug

12: 3/4" tube fitting

* Other connection standard, consult factory

Port Selection

VSR - 9200UAPS - 20 - V4 - 4PL - 1 - 2 - 3 - 4

Installation

P: panel mount*

BP: bonnet port(1/8"NPT)

None: bottom mount

* Panel hole ϕ 39.6mm

Materials

S: 316L

Outlet Pressure

V2: vac to 30 psig

V4: vac to 60 psig

V7: vac to 100 psig

V10: vac to 150 psig

2: to 30 psig

4: to 60 psig

7: to 100 psig

10: to 150 psig

Inlet Pressure

20: 300 psig

Ordering Example

VSR - 9200UAS - 20 - 10 - 4PL - F12 - F4 - F12 - B

1 - 2 - 3 - 4



Single Stage Pressure Regulators

VSR-1000UB Series

Product Feature

- Single-stage pressure regulator
- 10µin Ra surface finish (25 µin. Ra optional)
- Minimized internal volume for short purge times
- All gas-wetted parts made of stainless steel SS 316L, Hastelloy C276 and PCTFE respectively
- Internal connectors for pressure gauges
- Flow capacity: to 30 slpm(standard), to 120 slpm(option)
- High control accuracy
- Metal-to-metal seal to atmosphere
- Simple outlet pressure limitation by hand-wheel
- 100 % helium-leak-tested
- Cleaned for O₂ service



Dimensions(mm)

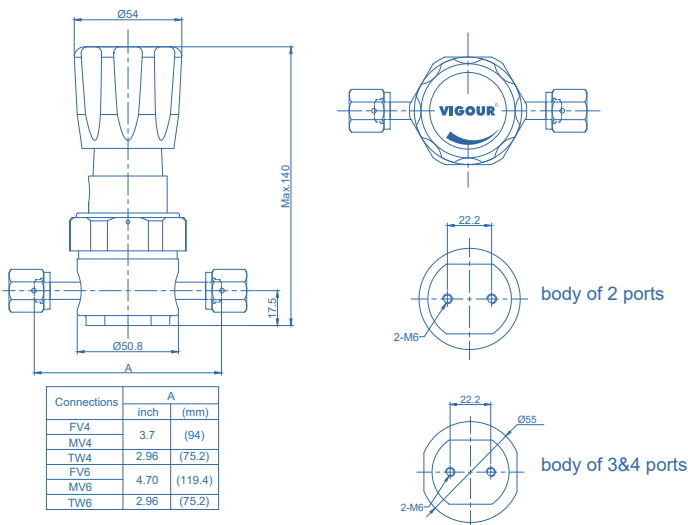

Technical Data

Type	single-stage
Inlet pressure P1	max. 3500 psig
Outlet pressure P2	10/30/60/100/150 psig
Surface finish	10µin.Ra (25µin.Ra optional)
Materials	
Body	see ordering info
Valve seat	PCTFE
Diaphragm	Hastelloy® C276
Inlets and Outlets	1/4" / 3/8" face seal and tube weld
Bonnet port	1/8"NPT(on panel mount option, bonnet port is not threaded)
Temperature range	-40°F to +160°F (-40°C to +71°C)
Leak rate (to atmosphere)	1x10 ⁻⁹ mbar l/s He
Leak rate (via seat)	1x10 ⁻⁸ mbar l/s He
Flow capacity	Cv=0.09 (Cv=0.15 option)
Weight	approx. 1.35 kg (depending on connections) 0.35 psig rise in delivery pressure per 100 psig source pressure drop @Cv=0.09
Supply pressure effect	0.5 psig rise in delivery pressure per 100 psig source pressure drop @Cv=0.15

Flowchart

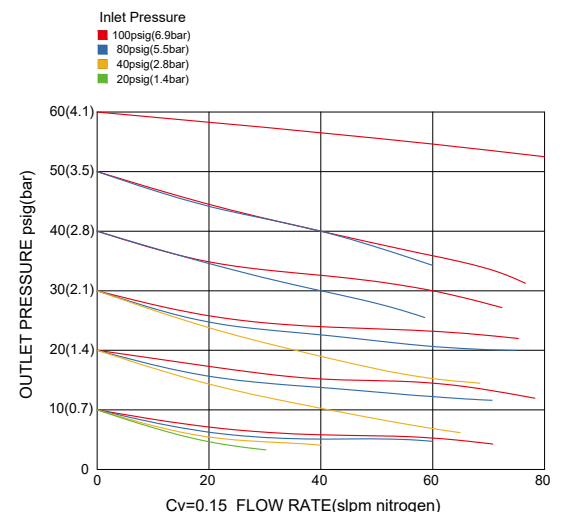
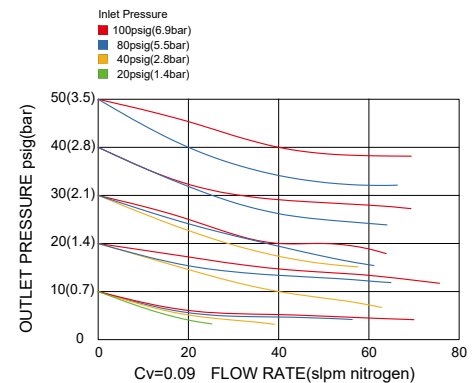
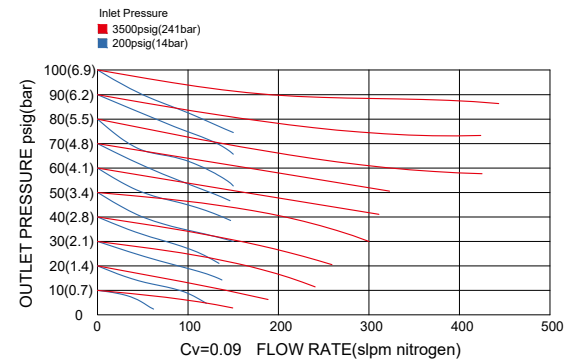

Single Stage Pressure Regulators VSR-1000UB Series

Ordering Information

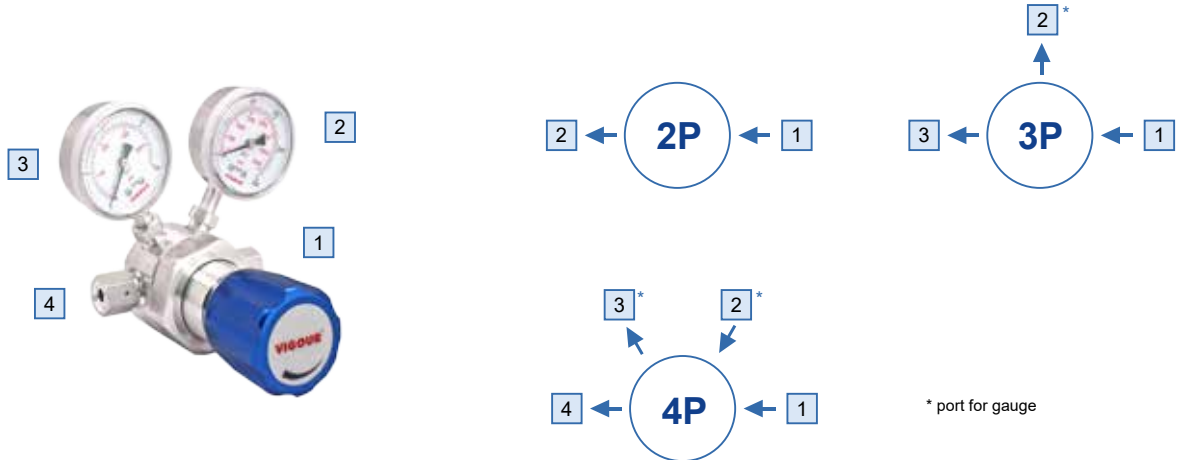

Inlet/outlet Connection

- | | |
|----------------------------|---------------------|
| FV4: 1/4" face seal female | TW4: 1/4" tube weld |
| MV4: 1/4" face seal male | TW6: 3/8" tube weld |
| FV6: 3/8" face seal female | P: gauge |
| MV6: 3/8" face seal male | |

* Other connection standard, consult factory

Port Selection

VSR - 1000UBPS - 250 - 10 - 4P - 1 - 2 - 3 - 4 - R25 - HF

Installation

- None: bottom mount
- P: panel mount

* Panel hole ϕ 36mm

Materials

- S: 316L
- H: Monel[®] alloy

Inlet Pressure

- 20: 300 psig
- 250: 3500 psig

Outlet Pressure

- V1: Vac to 10 psig
- V2: Vac to 30 psig
- V4: Vac to 60 psig
- V7: Vac to 100 psig
- V10: Vac to 150 psig
- 1: to 10 psig
- 2: to 30 psig
- 4: to 60 psig
- 7: to 100 psig
- 10: to 150 psig

Cv Option

- None: Cv=0.09
- HF: Cv=0.15

Surface Finish

- None: 10 μ m.Ra
- R25: 25 μ m.Ra

Port Config

- 2P: 2 ports
- 3P: 3 ports
- 4P: 4 ports

Ordering Example

VSR - 1000UBS - 250 - 10 - FV4 - P - P - FV4

1 - 2 - 3 - 4



Single Stage Pressure Regulators

VSR-1000UC Series

Product Feature

- Single-stage pressure regulator
- 15 μm . Ra max, 10 μm Ra average surface finish (10 μm .Ra max,7 μm .Ra max,5 μm .Ra max optional)
- Minimized internal volume for short purge times
- All gas-wetted parts made of stainless steel SS 316L,Hastelloy C276 and PCTFE respectively
- Internal connectors for pressure gauges
- Flow capacity: to 30 slpm(standard), to 120 slpm(option)
- High control accuracy
- Metal-to-metal seal to atmosphere
- Simple outlet pressure limitation by hand-wheel
- 100 % helium-leak-tested
- Cleaned for O₂ service

Dimensions(mm)

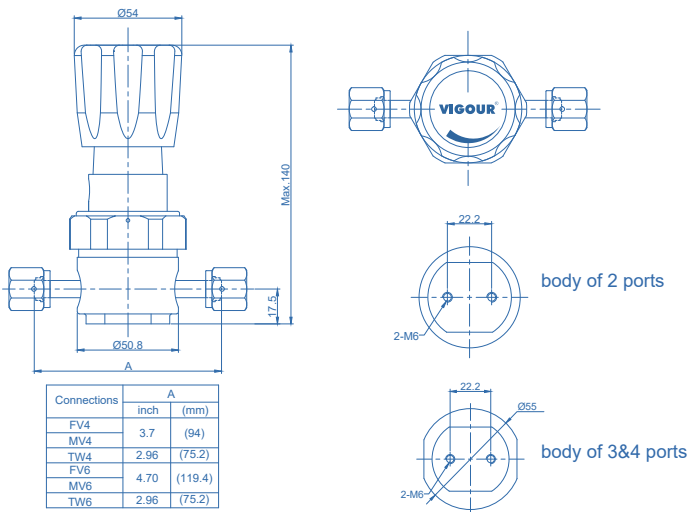

Technical Data

Type	single-stage
Inlet pressure P1	max. 3500 psig
Outlet pressure P2	10/30/60/100/150 psig
Surface finish	15 μm .Ra max/10 μm .Ra avg(10 μm .Ra max,7 μm .Ra max,5 μm .Ra max optional)
Materials	
Body	see ordering info
Valve seat	PCTFE
Diaphragm	Hastelloy [®] C276
Inlets and Outlets	1/4" / 3/8" face seal and tube weld
Bonnet port	1/8"NPT(on panel mount option,bonnet port is not threaded)
Temperature range	-40°F to +160°F (-40°C to +71°C)
Leak rate (to atmosphere)	1x10 ⁻⁹ mbar l/s He
Leak rate (via seat)	1x10 ⁻⁸ mbar l/s He
Flow capacity	Cv=0.09 (Cv=0.15 option)
Weight	approx. 1.35 kg (depending on connections) and options
Supply pressure effect	0.35 psig rise in delivery pressure per 100 psig source pressure drop@Cv=0.09 0.5 psig rise in delivery pressure per 100 psig source pressure drop@Cv=0.15



Flowchart

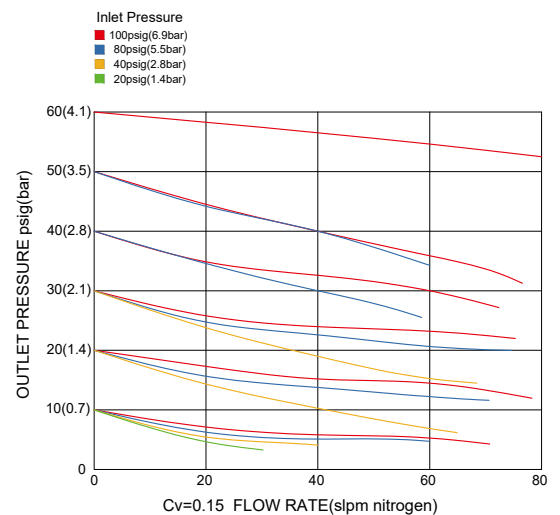
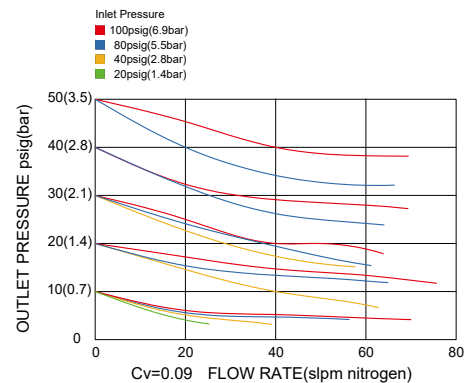
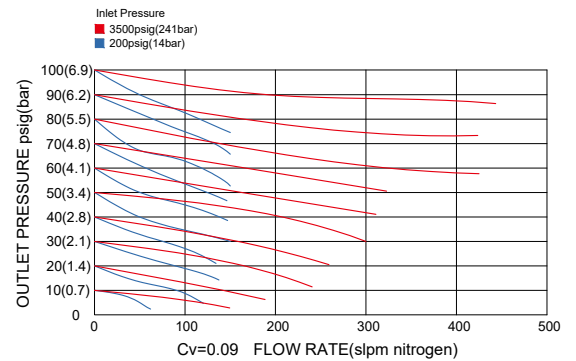

Single Stage Pressure Regulators VSR-1000UC Series

Ordering Information

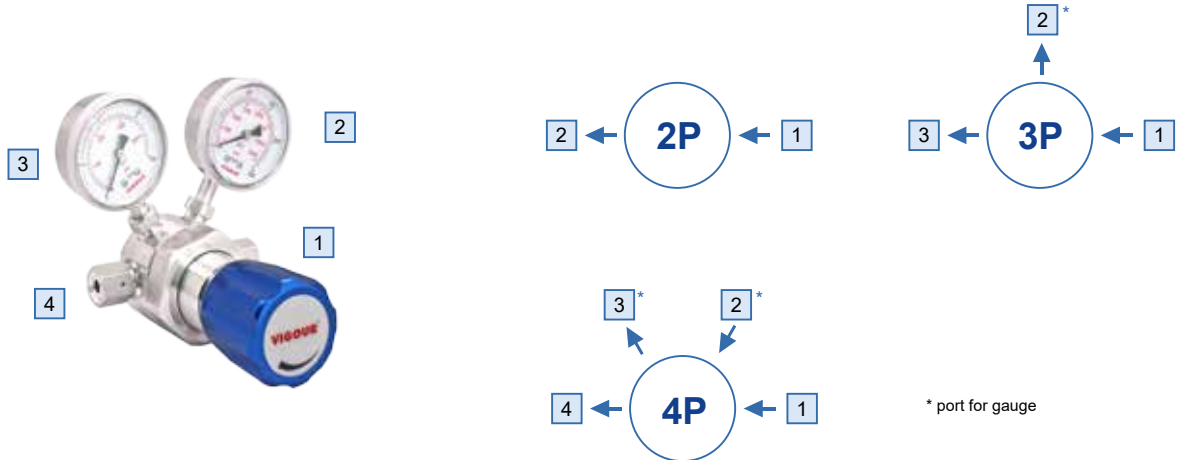

Inlet/outlet Connection

- | | |
|----------------------------|---------------------|
| FV4: 1/4" face seal female | TW4: 1/4" tube weld |
| MV4: 1/4" face seal male | TW6: 3/8" tube weld |
| FV6: 3/8" face seal female | P: gauge |
| MV6: 3/8" face seal male | |

* Other connection standard, consult factory

Port Selection

VSR - 1000UCPS - 250 - 10 - 4P - 1 - 2 - 3 - 4 - R5 - HF

Installation

- None: bottom mount
- P: panel mount

* Panel hole ϕ 36mm

Materials

- S: 316L secondary remelt
- H: Monel[®] alloy

Inlet Pressure

- 20: 300 psig
- 250: 3500 psig

Outlet Pressure

- V1: Vac to 10 psig
- V2: Vac to 30 psig
- V4: Vac to 60 psig
- V7: Vac to 100 psig
- V10: Vac to 150 psig
- 1: to 10 psig
- 2: to 30 psig
- 4: to 60 psig
- 7: to 100 psig
- 10: to 150 psig

Cv Option

- None: Cv=0.09
- HF: Cv=0.15

Surface Finish

- None: 15 μ m Ra max
- R10: 10 μ m Ra max
- R7: 7 μ m Ra max
- R5: 5 μ m Ra max

Port Config

- 2P: 2 ports
- 3P: 3 ports
- 4P: 4 ports

Ordering Example

VSR - 1000UCS - 250 - 10 - FV4 - P - P - FV4

1 - 2 - 3 - 4



Single Stage Pressure Regulators

VSR-1600UB Series

Product Feature

- Single-stage pressure regulator
- 10µin Ra surface finish (25 µin. Ra optional)
- Minimized internal volume for short purge times
- All gas-wetted parts made of stainless steel SS 316L, Hastelloy C276 and PCTFE respectively
- Internal connectors for pressure gauges
- Flow capacity: to 100 slpm
- High control accuracy
- Metal-to-metal seal to atmosphere
- Simple outlet pressure limitation by hand-wheel
- 100 % helium-leak-tested
- Cleaned for O₂ service



Dimensions(mm)

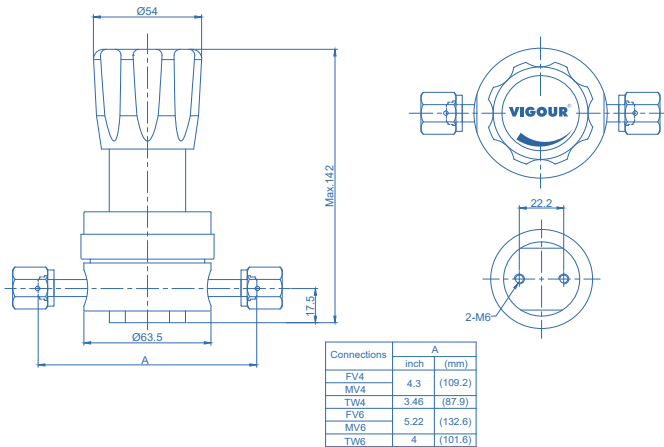

Technical Data

Type	single-stage
Inlet pressure P1	max. 3500 psig
Outlet pressure P2	10/30/60/100 psig
Surface finish	10µin.Ra (25µin.Ra optional)
Materials	
Body	see ordering info
Valve seat	PCTFE
Diaphragm	Hastelloy®C276
Inlets and Outlets	1/4" / 3/8" or 1/2" face seal or tube weld
Bonnet port	1/8" NPT (on panel mount option, bonnet port is not threaded)
Temperature range	-40°F to +160°F (-40°C to +71°C)
Leak rate (to atmosphere)	1x10 ⁻⁹ mbar l/s He
Leak rate (via seat)	1x10 ⁻⁸ mbar l/s He
Flow capacity	Cv=0.13
Weight	approx. 1.54 kg (depending on connections and options)
Supply pressure effect	0.25 psig rise in delivery pressure per 100 psig source pressure drop

Flowchart

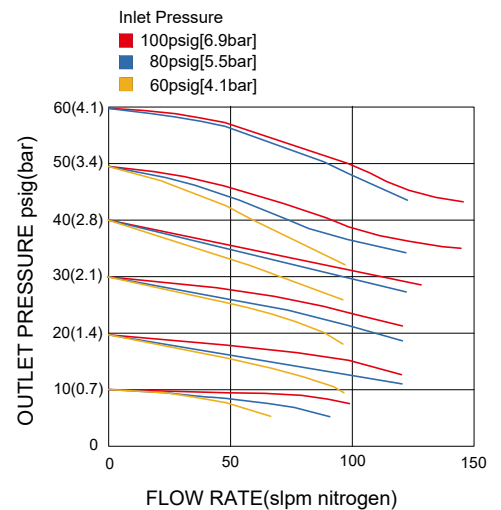
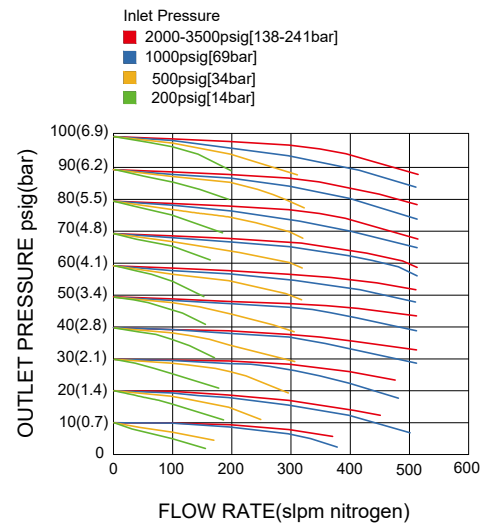

Single Stage Pressure Regulators VSR-1600UB Series

Ordering Information

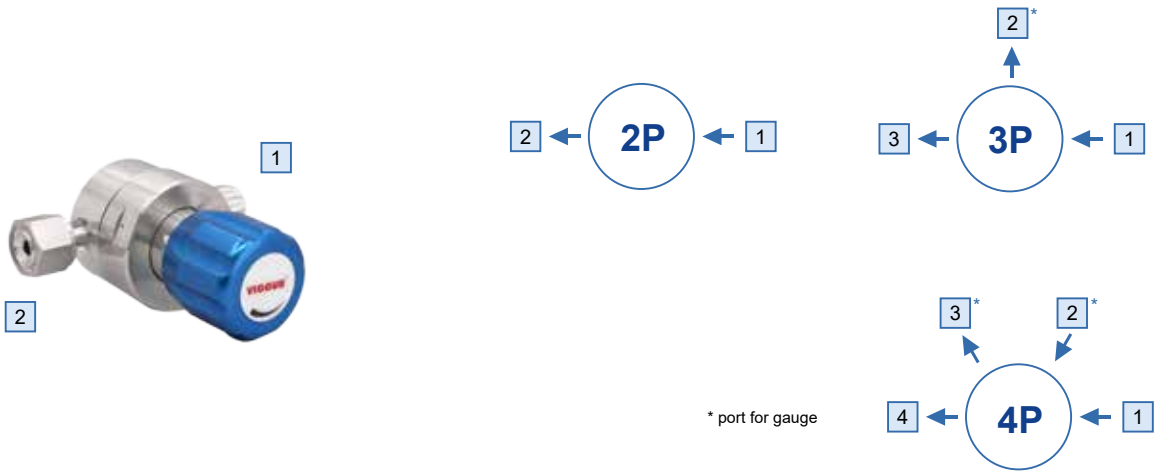

* port for gauge

Inlet/outlet Connection

FV4: 1/4" face seal female	TW4: 1/4" tube weld
MV4: 1/4" face seal male	TW6: 3/8" tube weld
FV6: 3/8" face seal female	TW8: 1/2" tube weld
MV6: 3/8" face seal male	P: gauge

* Other connection standard, consult factory

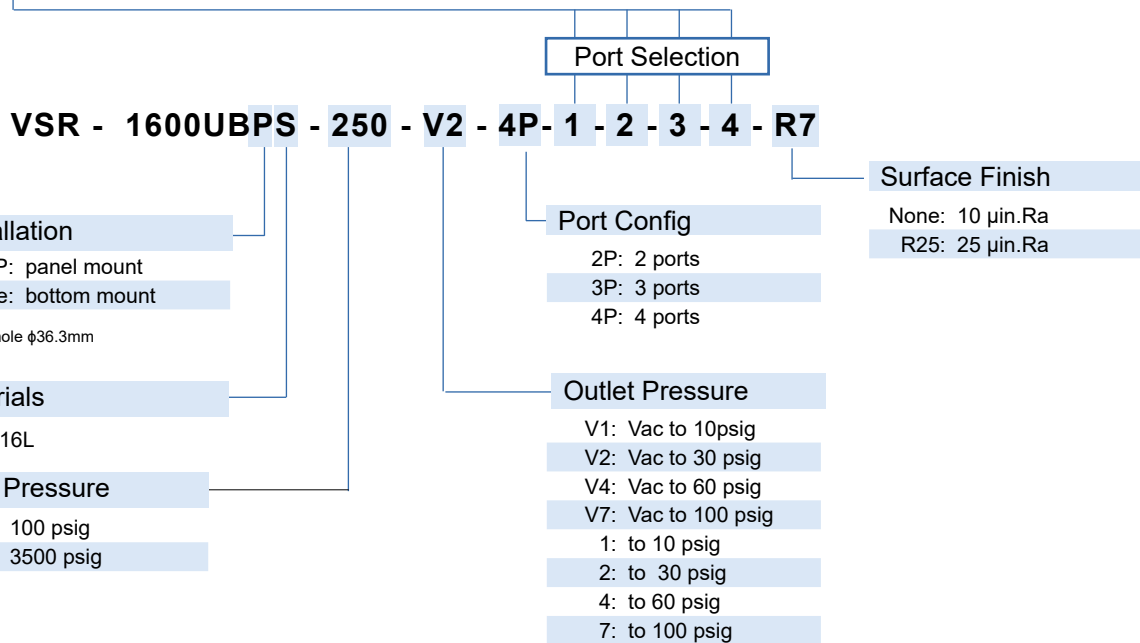

Ordering Example

VSR - 1600UBS - 250 - V4 - 2P - MV4 - FV4

1 - 2



Single Stage Pressure Regulators

VSR-1600UC Series

Product Feature

- Single-stage pressure regulator
- 15 μm . Ra max, 10 μm Ra average surface finish (10 μm .Ra max, 7 μm . Ra max, 5 μm . Ra max optional)
- Minimized internal volume for short purge times
- All gas-wetted parts made of stainless steel SS 316L, Hastelloy C276 and PCTFE respectively
- Internal connectors for pressure gauges
- Flow capacity: to 100 slpm
- High control accuracy
- Metal-to-metal seal to atmosphere
- Simple outlet pressure limitation by hand-wheel
- 100 % helium-leak-tested
- Cleaned for O₂ service

Dimensions(mm)

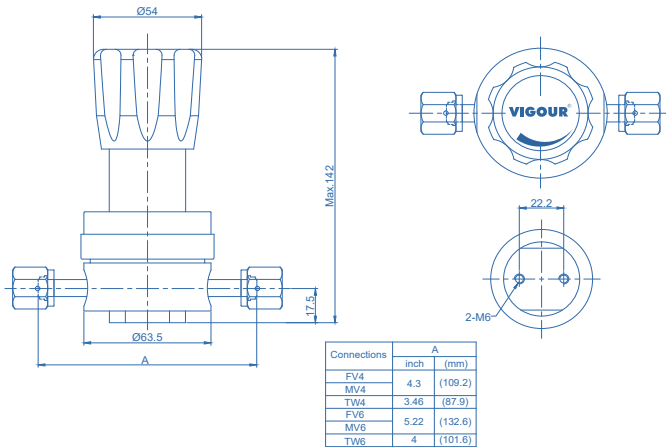

Technical Data

Type	single-stage
Inlet pressure P1	max. 3500 psig
Outlet pressure P2	10/30/60/100 psig
Surface finish	15 μm .Ra max/10 μm .Ra avg(10 μm .Ra max., 7 μm .Ra max., 5 μm .Ra max optional)
Materials	
Body	see ordering info
Valve seat	PCTFE
Diaphragm	Hastelloy®C276
Inlets and Outlets	1/4" / 3/8" or 1/2" face seal or tube weld
Bonnet port	1/8" NPT(on panel mount option, bonnet port is not threaded)
Temperature range	-40°F to +160°F (-40°C to +71°C)
Leak rate (to atmosphere)	1x10 ⁻⁹ mbar l/s He
Leak rate (via seat)	1x10 ⁻⁸ mbar l/s He
Flow capacity	Cv=0.13
Weight	approx.1.54 kg(depending on connections) and options
Supply pressure effect	0.25 psig rise in delivery pressure per 100 psig source pressure drop



Flowchart

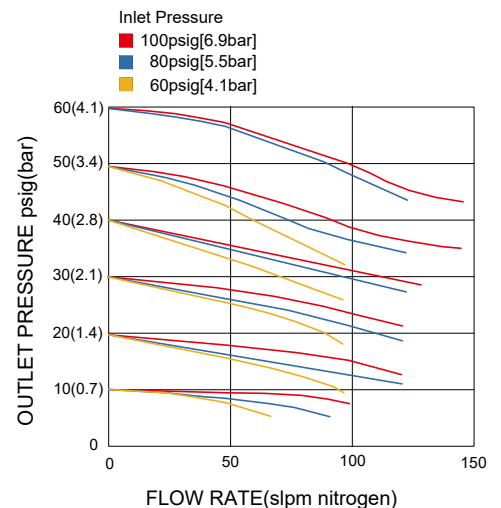
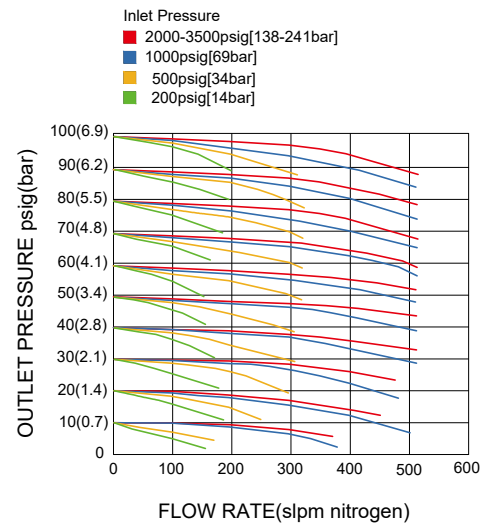

Single Stage Pressure Regulators VSR-1600UC Series

Ordering Information

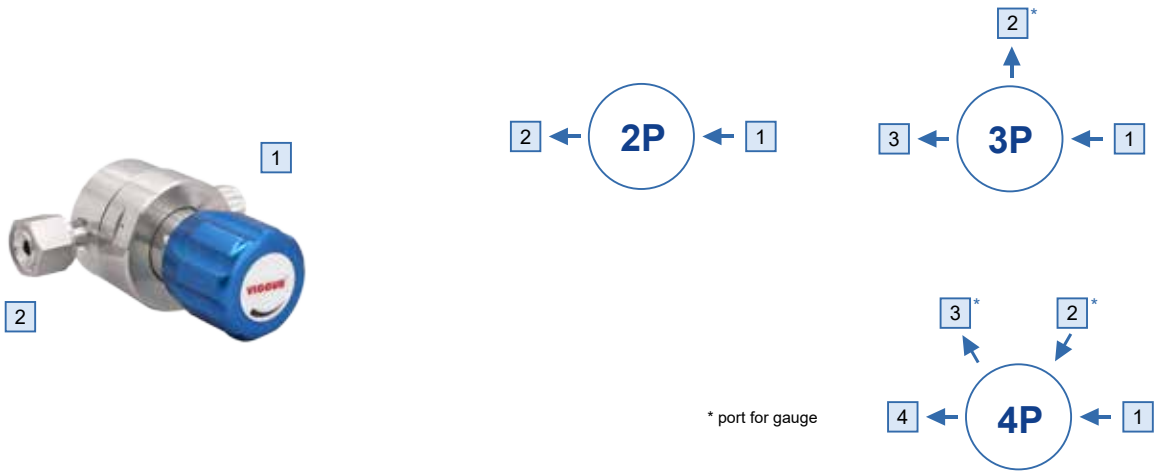

* port for gauge

Inlet/outlet Connection

FV4: 1/4" face seal female	TW4: 1/4" tube weld
MV4: 1/4" face seal male	TW6: 3/8" tube weld
FV6: 3/8" face seal female	TW8: 1/2" tube weld
MV6: 3/8" face seal male	P: gauge

* Other connection standard, consult factory

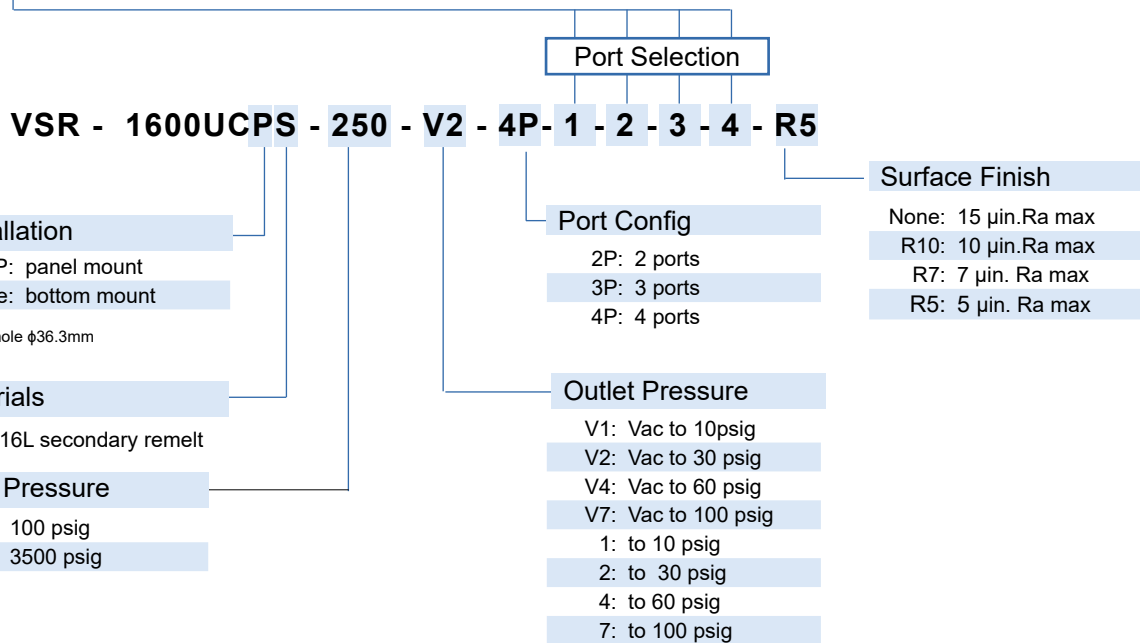

Ordering Example

VSR - 1600UCS - 250 - V4 - 2P - MV4 - FV4

1 - 2



Single Stage Pressure Regulators

VSR-9200UB Series

Product Feature

- Single-stage pressure regulator
- 10 μm . Ra surface finish
- Minimized internal volume for short purge times
- All gas-wetted parts made of stainless steel SS 316L, Hastelloy C276 and PCTFE respectively
- Internal connectors for pressure gauges
- Flow capacity: to 2000 slpm
- High control accuracy
- Metal-to-metal seal to atmosphere
- Simple outlet pressure limitation by hand-wheel
- 100 % helium-leak-tested
- Cleaned for O₂ service



Dimensions(mm)

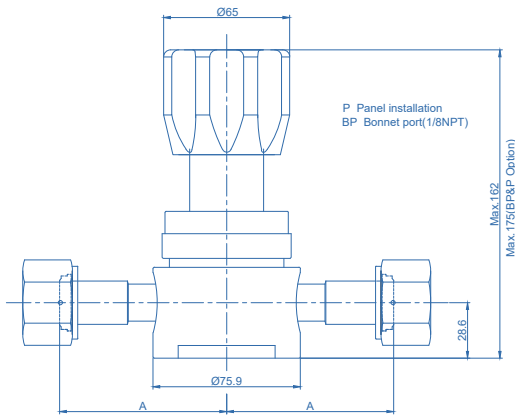

Connections	A	
	inch	(mm)
FV12	3.39	(86.1)
MV12	3.00	(76.2)
TW12	3.00	(76.2)
FV16	3.67	(93.2)
MV16	3.00	(76.2)
TW16	3.00	(76.2)

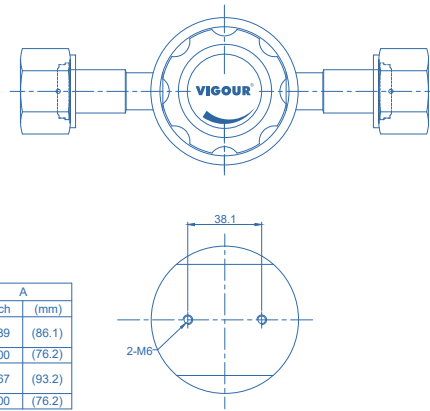

Technical Data

Type	single-stage
Inlet pressure P1	max. 300 psig
Outlet pressure P2	30/60/100/150 psig
Surface finish	10 μm . Ra
Materials	
Body	see ordering info
Valve seat	PFA
Diaphragm	Hastelloy® C276
Inlets and Outlets	3/4" / 1" Face seal or tube weld
Bonnet port	1/8" FNPT(option)
Temperature range	-40°F to +160°F (-40°C to +71°C)
Leak rate (to atmosphere)	1x10 ⁻⁹ mbar l/s He
Leak rate (via seat)	1x10 ⁻⁸ mbar l/s He
Flow capacity	Cv=1.6
Weight	approx.2.72kg (depending on connections and options)
Supply pressure effect	7 psig rise in delivery pressure per 100 psig source pressure drop

Flowchart

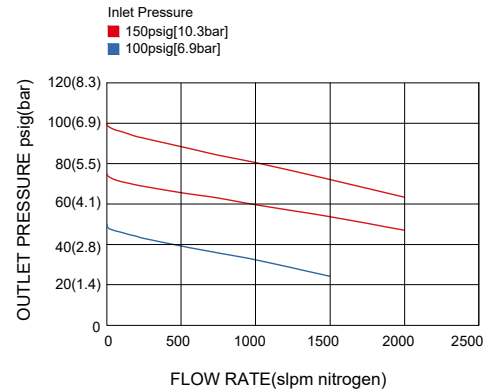

Single Stage Pressure Regulators VSR-9200UB Series

Ordering Information

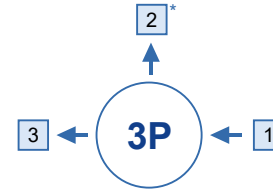

* port for gauge

Inlet/Outlet Connection

FV12: 3/4" face seal female
MV12: 3/4" face seal male
FV16: 1" face seal female
MV16: 1" face seal male

FV4: 1/4" face seal female (for gauge port)
MV4: 1/4" face seal male (for gauge port)

TW12: 3/4" tube weld
TW16: 1" tube weld
P: gauge

* Other connection standard, consult factory

Port Selection

VSR - 9200UBPS - 20 - V4 - 3P - 1 - 2 - 3

Installation

P: panel mount*
BP: bonnet port(1/8"FNPT)
None: bottom mount
* Panel hole ϕ 39.6mm

Materials

S: 316L

Outlet Pressure

V2: vac to 30 psig
V4: vac to 60 psig
V7: vac to 100 psig
V10: vac to 150 psig
2: to 30 psig
4: to 60 psig
7: to 100 psig
10: to 150 psig

Inlet Pressure

20: 300 psig

Ordering Example

VSR - 9200UBS - 20 - 10 - 2P - MV12 - FV12

1 - 2



Single Stage Pressure Regulators

VSR-9200UC Series

Product Feature

- Single-stage pressure regulator
- 10 μm . Ra surface finish
- Minimized internal volume for short purge times
- All gas-wetted parts made of stainless steel SS 316L, Hastelloy C276 and PCTFE respectively
- Internal connectors for pressure gauges
- Flow capacity: to 2000 slpm
- High control accuracy
- Metal-to-metal seal to atmosphere
- Simple outlet pressure limitation by hand-wheel
- 100 % helium-leak-tested
- Cleaned for O₂ service



Dimensions(mm)

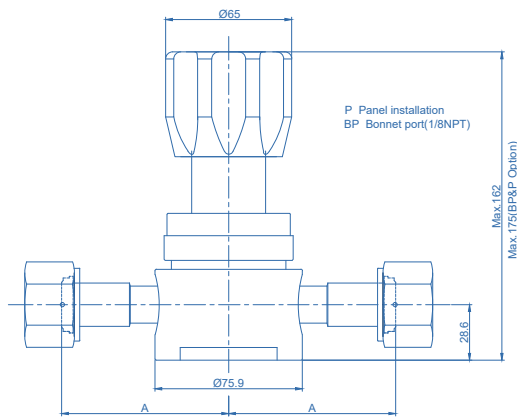

Connections	A	
	inch	(mm)
FV12	3.39	(86.1)
MV12	3.00	(76.2)
TW12	3.00	(76.2)
FV16	3.67	(93.2)
MV16	3.00	(76.2)
TW16	3.00	(76.2)

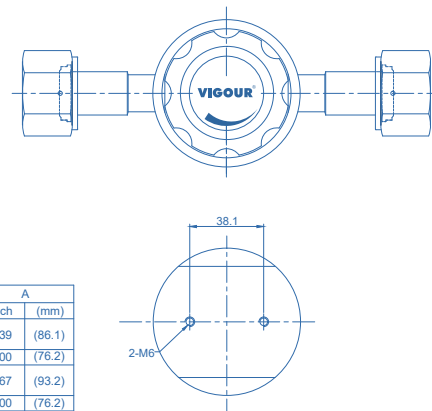

Technical Data

Type	single-stage
Inlet pressure P1	max. 300 psig
Outlet pressure P2	30/60/100/150 psig
Surface finish	10 μm . Ra
Materials	
Body	see ordering info
Valve seat	PFA
Diaphragm	Hastelloy®C276
Inlets and Outlets	3/4" / 1" Face seal or tube weld
Bonnet port	1/8" FNPT(option)
Temperature range	-40°F to +160°F (-40°C to +71°C)
Leak rate (to atmosphere)	1x10 ⁻⁹ mbar l/s He
Leak rate (via seat)	1x10 ⁻⁸ mbar l/s He
Flow capacity	Cv=1.6
Weight	approx.2.72kg (depending on connections and options)
Supply pressure effect	7 psig rise in delivery pressure per 100 psig source pressure drop

Flowchart

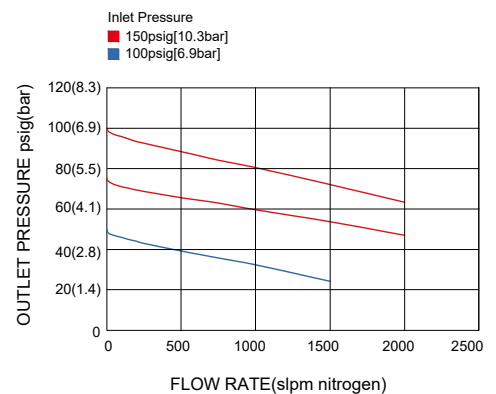

Single Stage Pressure Regulators VSR-9200UC Series

Ordering Information

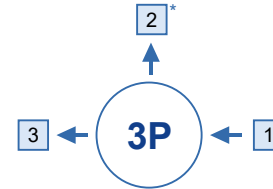

* port for gauge

Inlet/Outlet Connection

FV12: 3/4" face seal female
MV12: 3/4" face seal male
FV16: 1" face seal female
MV16: 1" face seal male

FV4: 1/4" face seal female
(for gauge port)
MV4: 1/4" face seal male
(for gauge port)

TW12: 3/4" tube weld
TW16: 1" tube weld
P: gauge

* Other connection standard, consult factory

Port Selection

VSR - 9200UCPS - 20 - V4 - 3P - 1 - 2 - 3

Installation

P: panel mount*
BP: bonnet port(1/8"FNPT)
None: bottom mount
* Panel hole ϕ 39.6mm

Materials

S: 316L secondary remelt

Outlet Pressure

V2: vac to 30 psig
V4: vac to 60 psig
V7: vac to 100 psig
V10: vac to 150 psig
2: to 30 psig
4: to 60 psig
7: to 100 psig
10: to 150 psig

Inlet Pressure

20: 300 psig

Ordering Example

VSR - 9200UCS - 20 - 10 - 2P - MV12 - FV12

1 - 2



Diaphragm Valves

VDV31UA Series

Temperature / Pressure Rating

- Diaphragm valve
- Suitable for high purity, flammable, corrosive or toxic fluid gases
- Inlet pressure max 300 bar
- Left or Right lever direction for Shutoff
- Wide range of inlets and outlets
- Metal-to-metal sealing to atmosphere



Temperature / Pressure Rating

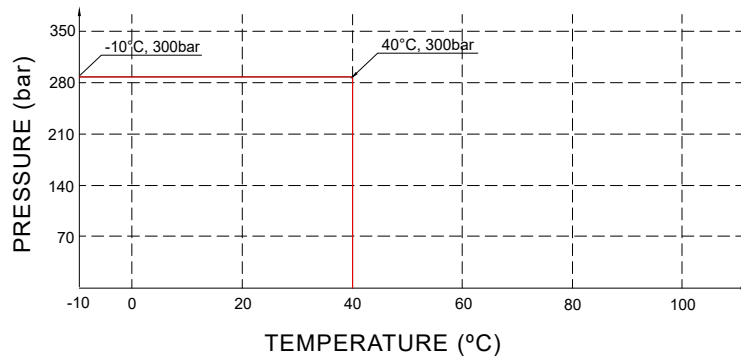

Schematic Drawing

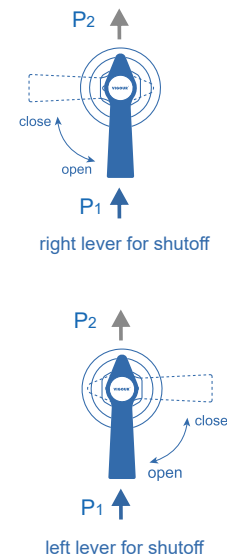

Technical Data

Max. Working Pressure	4500 psig (300 bar)
Max. Working Temp.	-10°F ~ 150°F (-23°C ~ 65°C)
Materials	
Body	316L
Diaphragm	Elgiloy®
Seat packing	PCTFE
Handle	AL
Internal Leakage Allowance(He)	1 x 10 ⁻⁹ atm • cc/sec
External Leakage Allowance (He)	1 x 10 ⁻⁹ atm • cc/sec
Orifice	Ø2.7 mm
Weight	approx.0.25 kg

Dimensions(mm)

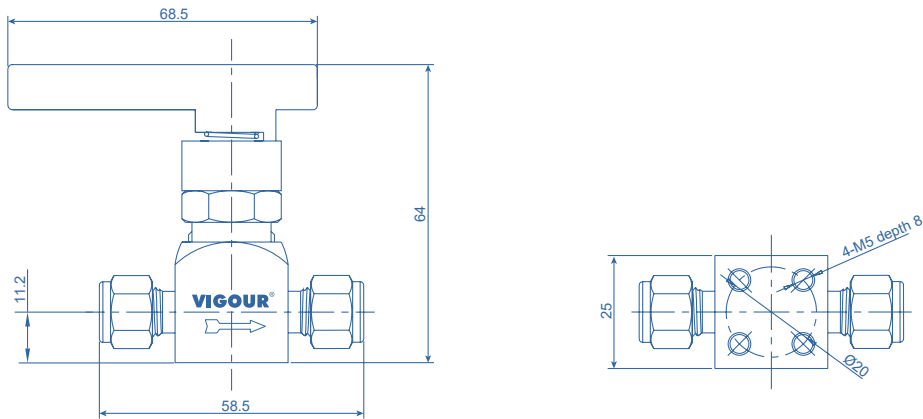

Ordering Information

VDV31UAS - 04 - 04 - L

Materials

S: 316L

Inlets / Outlets

M4: 1/4" NPT(M)

02: 1/8" tube fitting

04: 1/4" tube fitting

6M: 6mm tube fitting

8M: 8mm tube fitting

Lever

None: right lever for shutoff

L: left lever for shutoff

Diaphragm Valves

VDV32UA Series

Product Feature

- Suitable for high purity, flammable, corrosive or toxic fluid gases
- Direct diaphragm construction with superior sealing performance, remarkable durability, compactness and particle and dead-space-free performance
- Valve open and closed position is easily visible at a glance
- Excellent gas displacement characteristics
- Standard seat material is PCTFE. Ployimede/PFA is option



Temperature / Pressure Rating

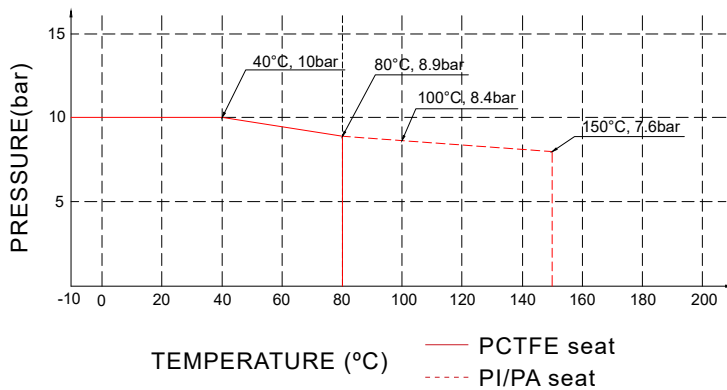

Technical Data

Max. Working Pressure	150 psig (10 bar)
Pneumatic Operating Pressure	58~87psig (4~6 bar)
Max. Working Temp.	-10°F ~ 150°F (-23°C ~ 65°C)
Materials	
Body	316L
Diaphragm	Elgiloy®
Seat packing	PCTFE(standard)
Handle	AL
Internal Leakage Allowance(He)	1 x 10 ⁻⁹ atm • cc/sec
External Leakage Allowance (He)	1 x 10 ⁻⁹ atm • cc/sec
Orifice	Ø4.4 mm
Weight	approx. 0.27 kg(actuator not included)

Diaphragm Valves VDV32UA Series

Dimensions(mm)

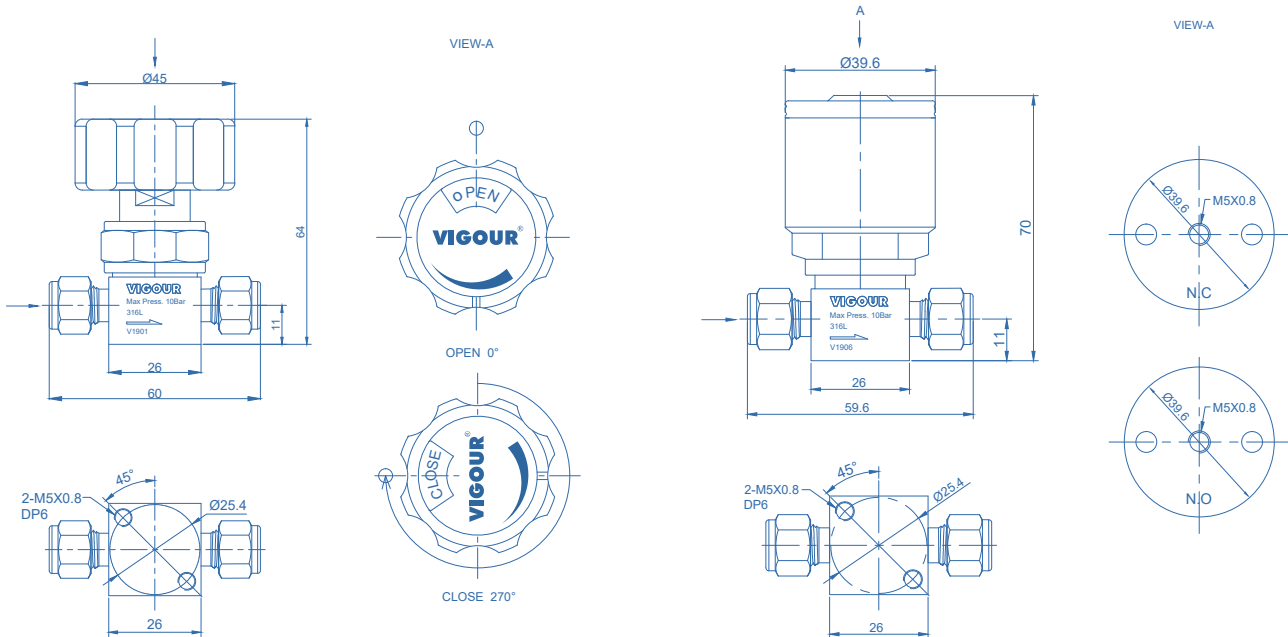

1/4" tube fitting dimensions for reference, other connections please contact factory.

Ordering Information

VDV32UAS - M - 04 - 04 - PA

Materials

S: 316L

Actuator

M: manual actuator

PO: pneumatic actuator, normally opened

PC: pneumatic actuator, normally closed

End Connection

F4: 1/4" FNPT

04: 1/4" tube fitting

06: 3/8" tube fitting

Seat Option

None: PCTFE(standard)

PI: Polyimide

PA: PFA

* Other connection standard, consult factory

Diaphragm Valves

VDV33UA Series

Product Feature

- Suitable for high purity, flammable, corrosive or toxic fluid gases
- Direct diaphragm construction with superior sealing performance, remarkable durability, compactness and particle and dead-space-free performance
- Valve open and closed position is easily visible at a glance
- Excellent gas displacement characteristics
- Standard seat material is PCTFE, Polyimide/PFA is option



Temperature / Pressure Rating

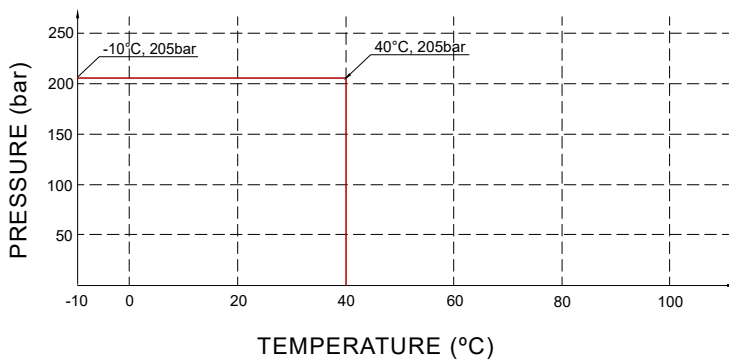

Technical Data

Max. Working Pressure	3000 psig (205 bar)
Pneumatic Operating Pressure	58~87psig (4~6 bar)
Max. Working Temp.	-10°F ~ 150°F (-23°C ~ 65°C)
Materials	
Body	316L
Diaphragm	Elgiloy®
Seat packing	PCTFE(standard)
Handle	AL
Internal Leakage Allowance(He)	1 x 10 ⁻⁹ atm • cc/sec
External Leakage Allowance (He)	1 x 10 ⁻⁹ atm • cc/sec
Orifice	Ø5 mm
Weight	approx. 0.27 kg(actuator not included)

Dimensions(mm)

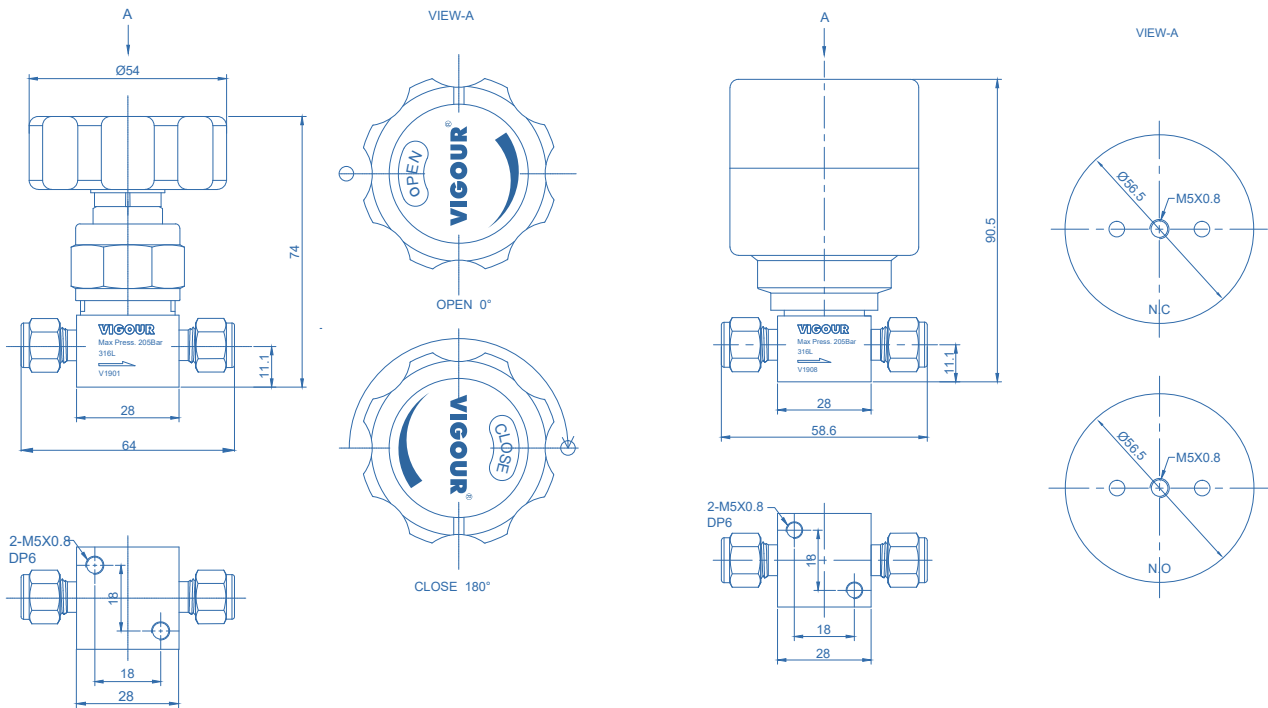

1/4" tube fitting dimensions for reference, other connections please contact factory.

Ordering Information

VDV33UAS - M - 04 - 04 - PA

Materials

S: 316L

Actuator

M: manual actuator

PO: pneumatic actuator, normally opened

PC: pneumatic actuator, normally closed

Seat Option

None: PCTFE(standard)

PA: PFA

PI: Polyimide

End Connection

F4: 1/4" FNPT

04: 1/4" tube fitting

* Other connection standard, consult factory

Diaphragm Valves

VDV31UB Series

Product Feature

- Quarter-turn ON/OFF, providing easy operation
- Left or Right lever direction for Shutoff
- Available on high and low-pressure models



Temperature / Pressure Rating

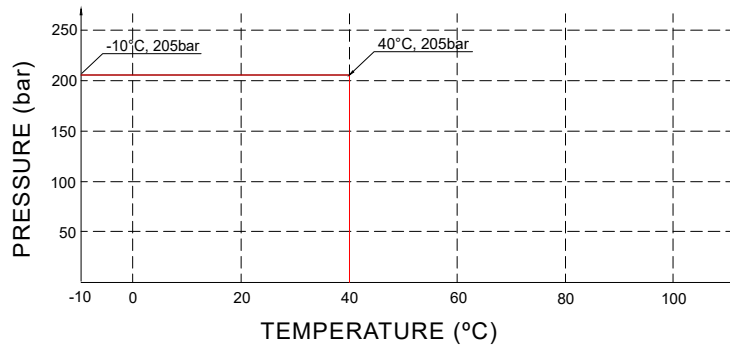

Technical Data

Max. Working Pressure	3000 psig (205 bar)
Max. Working Temp.	-10°F ~ 150°F (-23°C ~ 65°C)
Materials	
Body	316L secondary remelt
Diaphragm	Elgiloy®
Seat packing	PCTFE
Handle	AL
Internal Leakage Allowance(He)	1 x 10 ⁻⁹ atm • cc/sec
External Leakage Allowance (He)	1 x 10 ⁻⁹ atm • cc/sec
Orifice	Ø4.0 mm
Weight	approx. 0.25 kg

Diaphragm Valves VDV31UB Series

Dimensions(mm)

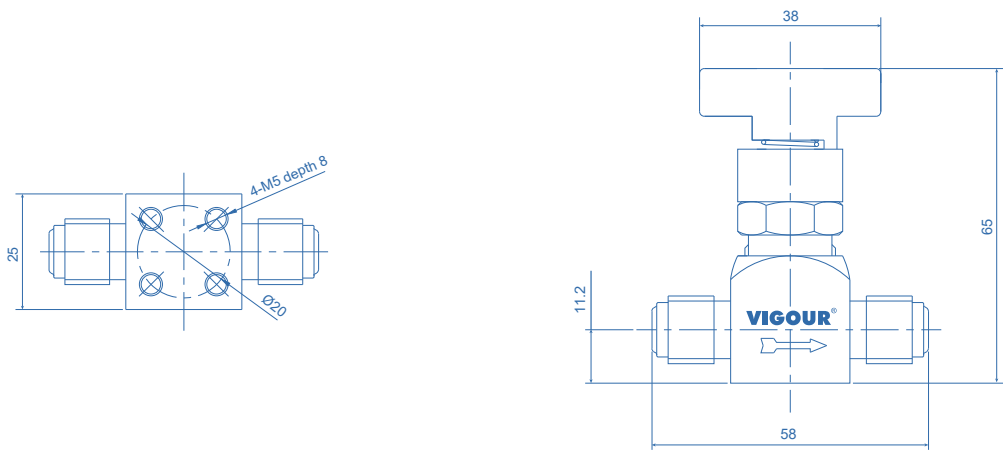

Ordering Information

VDV31UBS - MV4 - MV4

Materials

S: 316L secondary remelt

End Connection

MV4: 1/4" face seal male

* Other connection standard,consult factory

Diaphragm Valves

VDV32UB Series

Product Feature

- Suitable for ultra pure, flammable, corrosive or toxic fluid lines in semiconductor manufacturing equipment and facilities
- Direct diaphragm construction with superior sealing performance, remarkable durability, compactness and particle and dead-space-free performance
- Valve open and closed position is easily visible at a glance
- Excellent gas displacement characteristics
- EP treatment is standard for all wetted surfaces
- Standard seat material is PCTFE. Ployimede/PFA is option



Temperature / Pressure Rating

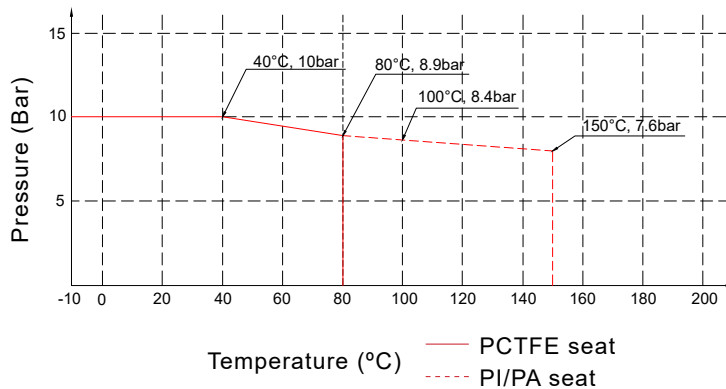

Technical Data

Max. Working Pressure	150 psig (10 bar)
Pneumatic Operating Pressure	58~87psig (4~6 bar)
Max. Working Temp.	-10°F ~ 150°F (-23°C ~ 65°C)
Materials	
Body	316L secondary remelt
Diaphragm	Elgiloy®
Seat packing	PCTFE(standard)
Handle	AL
Internal Leakage Allowance(He)	1 x 10 ⁻⁹ atm • cc/sec
External Leakage Allowance (He)	1 x 10 ⁻⁹ atm • cc/sec
Orifice	Ø4.4 mm
Weight	approx. 0.27 kg(actuator not included)

Diaphragm Valves VDV32UB Series

Dimensions(mm)

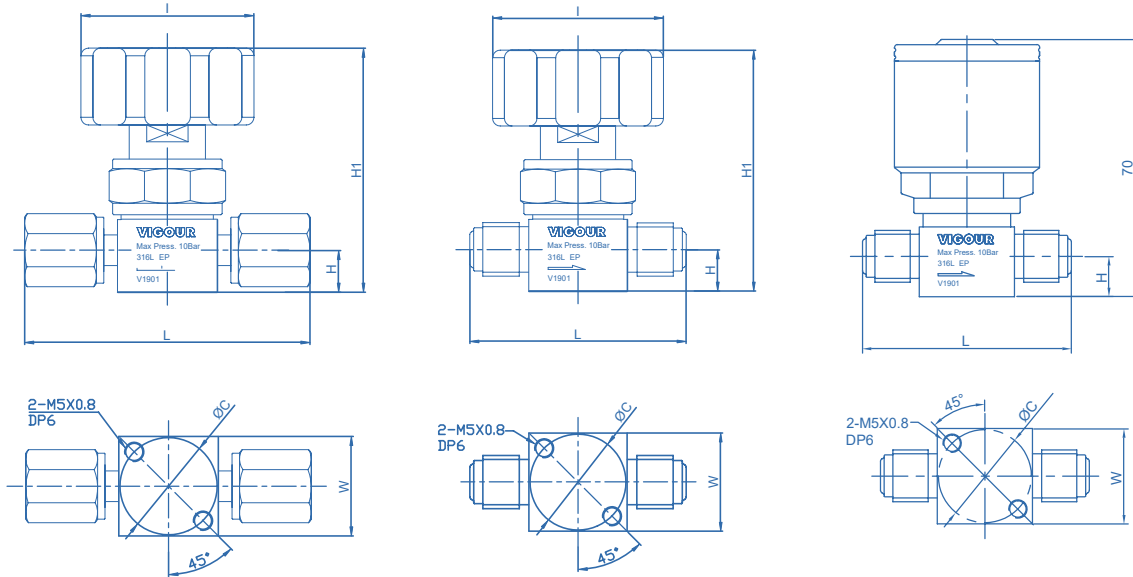

End Connection	Size in.	Dimensions in.(mm)					
		H	H1	L	I	W	C
MV4	1/4	0.433	2.520	2.244	1.772	1.024	1.000
		(11.0)	(64.0)	(57.0)	(45.0)	(26.0)	(25.4)
MV8	1/2	0.437	3.248	3.000	1.575	1.378	1.949
		(11.1)	(82.5)	(76.2)	(40.0)	(35.0)	(49.5)
FV4	1/4	0.563	2.933	2.780	1.575	1.024	1.000
		(14.3)	(74.5)	(70.6)	(40.0)	(26.0)	(25.4)
FV8	1/2	0.500	3.311	3.268	1.575	1.378	1.126
		(12.7)	(84.1)	(83.0)	(40.0)	(35.0)	(28.6)

Ordering Information

VDV32UBS - M - MV4 - MV4 - PA

Materials

S: 316L secondary remelt

Seat Option

None: PCTFE(standard)
PI: Polyimide
PA: PFA

Actuator

M: manual actuator
PO: pneumatic actuator, normally opened
PC: pneumatic actuator, normally closed

End Connection

MV4: 1/4" face seal male
FV4: 1/4" face seal female
MV8: 1/2" face seal male
FV8: 1/2" face seal female
TW4: 1/4" tube weld
TW8: 1/2" tube weld

* Other connection standard, consult factory

Diaphragm Valves

VDV33UB Series

Product Feature

- Suitable for ultra pure, flammable, corrosive or toxic fluid lines in semiconductor manufacturing equipment and facilities
- Direct diaphragm construction with superior sealing performance, remarkable durability, compactness and particle and dead-space-free performance
- Valve open and closed position is easily visible at a glance.
- Excellent gas displacement characteristics
- EP treatment is standard for all wetted surfaces
- Standard seat material is PCTFE, Polyimide/PFA is option



Temperature / Pressure Rating

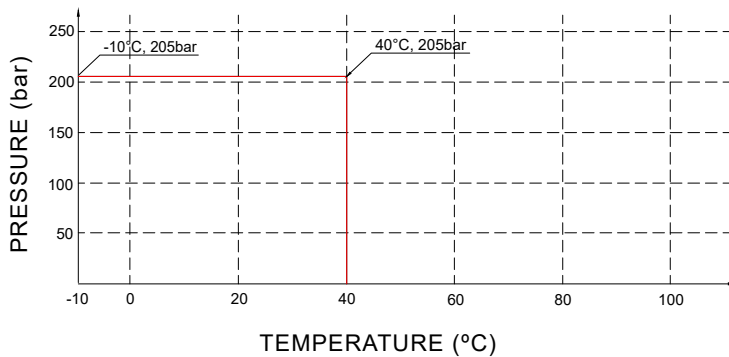

Technical Data

Max. Working Pressure	3000 psig (205 bar)
Pneumatic Operating Pressure	58~87psig (4~6 bar)
Max. Working Temp.	-10°F ~ 150°F (-23°C ~ 65°C)
Materials	
Body	316L secondary remelt
Diaphragm	Elgiloy®
Seat packing	PCTFE(standard)
Handle	AL
Internal Leakage Allowance(He)	1 x 10 ⁻⁹ atm • cc/sec
External Leakage Allowance (He)	1 x 10 ⁻⁹ atm • cc/sec
Orifice	Ø5 mm
Weight	approx. 0.27 kg(actuator not included)

Diaphragm Valves VDV33UB Series

Dimensions(mm)

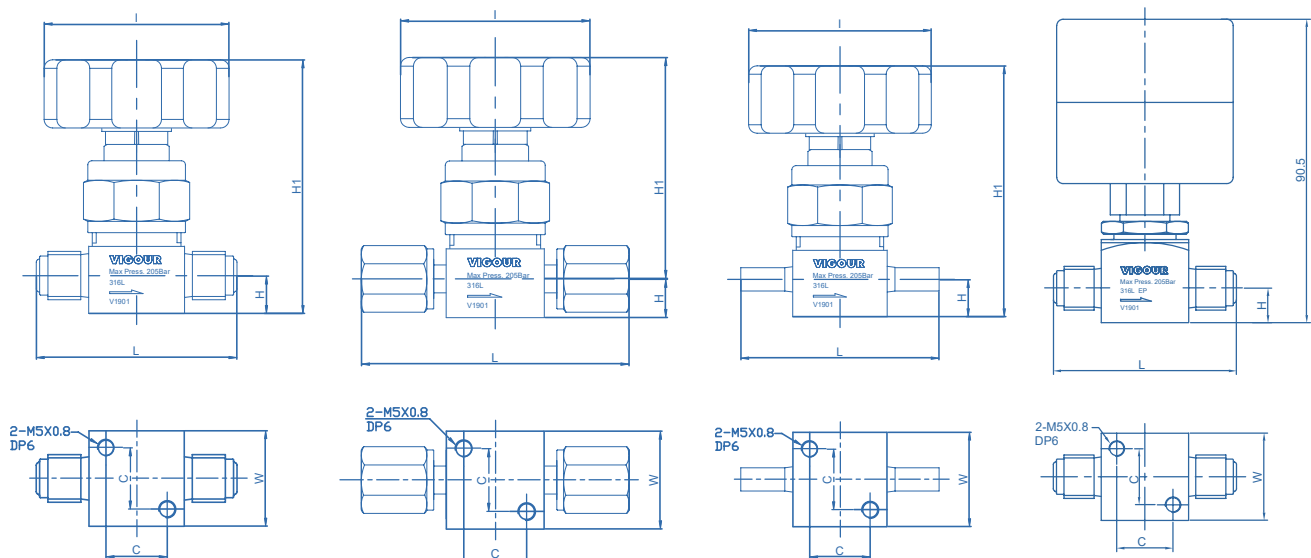

end connection	size in.	Dimensions in.(mm)					
		H	H1	L	I	W	C
MV4	1/4	0.437 (11.1)	2.913 (74.0)	2.307 (58.6)	2.126 (54.0)	1.102 (28.0)	0.709 (18.0)
MV8	1/2	0.437 (11.1)	3.213 (81.6)	3.000 (76.2)	1.969 (50.0)	1.102 (28.0)	0.709 (18.0)
FV4	1/4	0.437 (11.1)	3.075 (78.1)	3.000 (76.2)	1.969 (50.0)	1.102 (28.0)	0.709 (18.0)
TW4	1/4	0.437 (11.1)	3.075 (78.1)	2.913 (74.0)	1.969 (50.0)	1.102 (28.0)	0.709 (18.0)

Ordering Information

VDV33UBS - M - MV4 - MV4 - PA

Materials

S: 316L secondary remelt

Actuator

- M: manual actuator
- PO: pneumatic actuator, normally opened
- PC: pneumatic actuator, normally closed

Seat Option

- None: PCTFE(standard)
- PA: PFA
- PI: Polyimide

End Connection

- MV4: 1/4" face seal male
- FV4: 1/4" face seal female
- TW4: 1/4" tube weld
- MV8: 1/2" face seal male
- FV8: 1/2" face seal female
- TW8: 1/2" tube weld

* Other connection standard, consult factory

Face Seal Fittings VVR Series

General Information



Materials

Material	Ordering Number Designator	Specification
Glands, Bodies, and Nuts		
316L stainless steel	Standard	Bar stock: ASME SA479, ASTM A276 Forgings: ASME A182
316L secondary remelt stainless steel	-SLV	Bar stock: ASME SA479, ASTM A276 Forgings: ASME A182
Gaskets		
Nickel	-NI	ASTM B162
316L stainless steel	Standard	ASTM A240, ASTM A167

Dimensions

- Dimensions are for reference only and are subject to change.
- The D1 dimension refers to the smallest nominal inside diameter of the part.

Pressure Ratings

- Ratings are based upon tests conducted using VFS assemblies.
- All ratings comply with calculations per ANSI Code for Pressure Piping B31.3.
- To determine pressure ratings in accordance with ANSI B31.3, multiply psig rating by 0.94.
- Ratings determined at ambient temperature.

Components	Material	Temperature, °F (°C)
Fittings	316L stainless steel	1000 (537)
	316L secondary remelt stainless steel	1000 (537)
Gaskets	316L stainless steel	1000 (537)
	Nickel	600 (315)

Testing

The VFS assembly with silver plating has been helium leak tested to a rate of 4×10^{-9} std cm³/s and the unplated gasket to a rate of 4×10^{-11} std cm³/s without leakage.

Face seal Fittings VVR Series

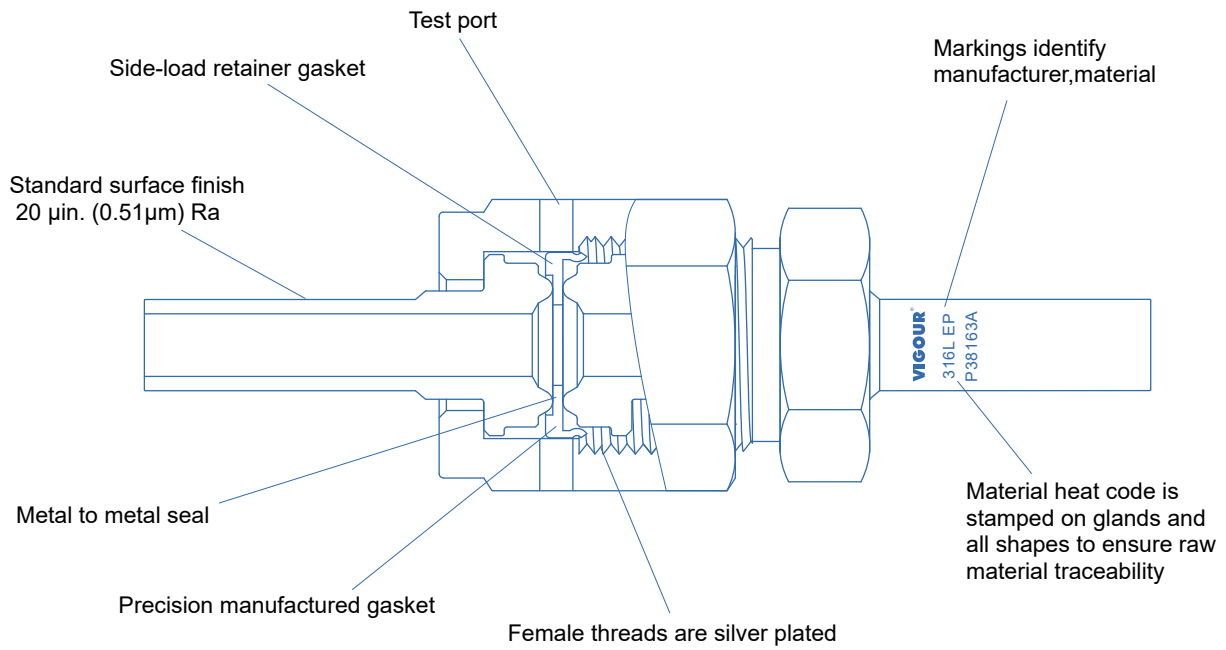

Typical VFS Assemblies

VFS assemblies are made up of four or five basic components.

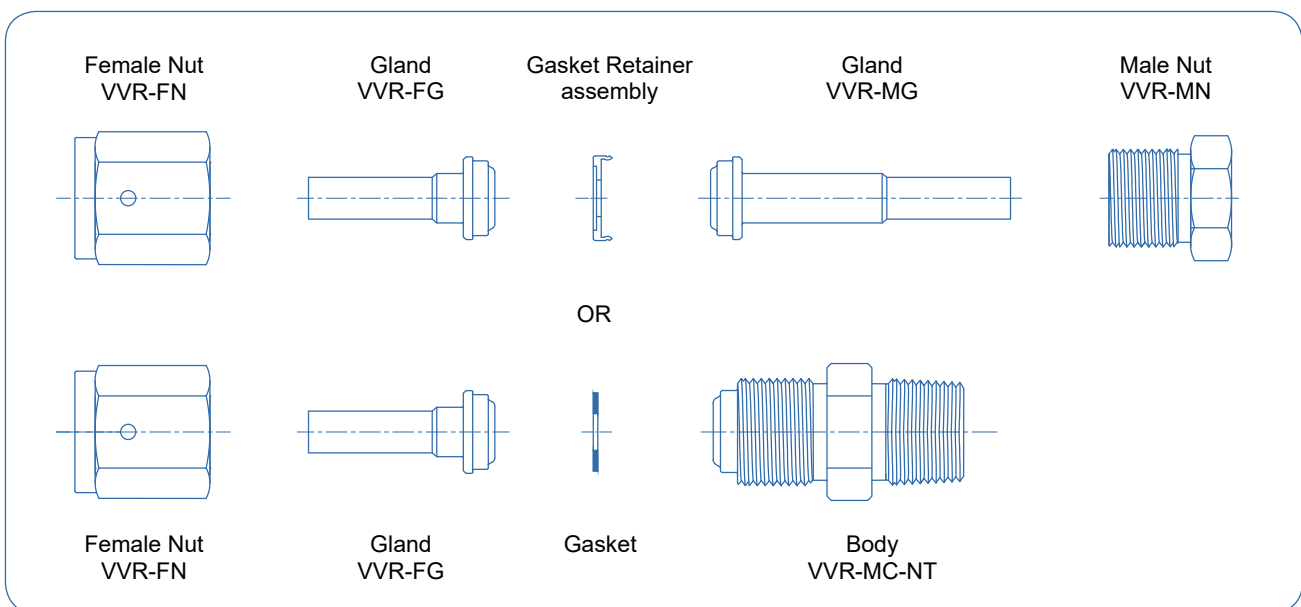

Face Seal Fittings

VVR Series

Glands

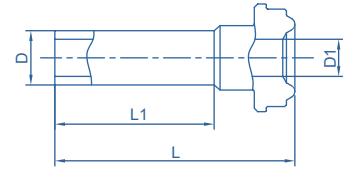

Short Tube Butt Weld

D Tube OD in.	Wall Thickness in.	VFS Size in.	Material	Ordering Number	Dimensions, in.(mm)			Working Pressure psig(bar)
					L1	D1	L	
1/8	0.028	1/8	316L	VVR-FG2-TB2 ^①	0.75	0.06	1.08	8500
			316L secondary remelt	VVR-FG2-TB2-SLV ^①	(19.1)	(1.5)	(27.4)	(585)
1/4	0.035	1/4	316L	VVR-FG4-TB4	0.75	0.18	1.10	5100
			316L secondary remelt	VVR-FG4-TB4-SLV	(19.1)	(4.6)	(27.9)	(351)
3/8	0.035	1/2	316L	VVR-FG8-TB6	0.75	0.31	1.12	3300
			316L secondary remelt	VVR-FG8-TB6-SLV	(19.1)	(7.9)	(28.4)	(227)
1/2	0.049	1/2	316L	VVR-FG8-TB8	0.75	0.40	1.12	3500
			316L secondary remelt	VVR-FG8-TB8-SLV	(19.1)	(10.2)	(28.4)	(241)

① not design for gasket retainer assembly

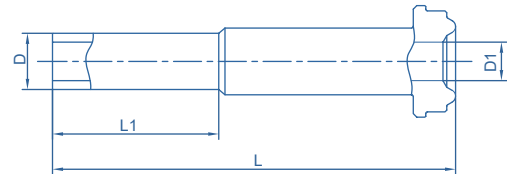

Long Tube Butt Weld

D Tube OD in.	Wall Thickness in.	VFS Size in.	Material	Ordering Number	Dimensions, in.(mm)			Working Pressure psig(bar)
					L1	D1	L	
1/8	0.028	1/8	316L	VVR-MG2-TB2 ^①	0.75	0.06	1.42	8500
			316L secondary remelt	VVR-MG2-TB2-SLV ^①	(19.1)	(1.5)	(36.1)	(585)
1/4	0.035	1/4	316L	VVR-MG4-TB4	0.75	0.18	1.70	5100
			316L secondary remelt	VVR-MG4-TB4-SLV	(19.1)	(4.6)	(43.2)	(351)
3/8	0.035	1/2	316L	VVR-MG8-TB6	0.75	0.31	1.79	3300
			316L secondary remelt	VVR-MG8-TB6-SLV	(19.1)	(7.9)	(45.5)	(227)
1/2	0.049	1/2	316L	VVR-MG8-TB8	0.75	0.40	1.79	3500
			316L secondary remelt	VVR-MG8-TB8-SLV	(19.1)	(10.2)	(45.5)	(241)
3/4	0.049	3/4	316L	VVR-MG12-TB12	0.75	0.65	2.03	2400
			316L secondary remelt	VVR-MG12-TB12-SLV	(19.1)	(16.5)	(51.6)	(165)
1	0.065	1	316L	VVR-MG16-TB16	0.75	0.87	2.32	2400
			316L secondary remelt	VVR-SLV-MG16-TB16	(19.1)	(22.1)	(58.9)	(165)

① not design for gasket retainer assembly

Gasket Retainer Assembly

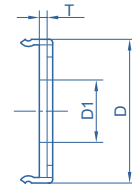

VFS Size in.	Ordering Number	Material	Dimension, in.(mm)		
			D1	T	D
1/4	VVR-GKR-G4	316L	0.24(6.1)	0.028(0.7)	0.50(12.7)
	VVR-GKR-G4-Ni	Nickel			
1/2	VVR-GKR-G8	316L	0.44 (11.2)	0.028(0.7)	0.79(20.1)
	VVR-GKR-G8-Ni	Nickel			
3/4	VVR-GKR-G12	316L	0.66(16.8)	0.028(0.7)	1.14(29.0)
	VVR-GKR-G12-Ni	Nickel			
1	VVR-GKR-G16	316L	0.89(22.6)	0.028(0.7)	1.40(35.6)
	VVR-GKR-G16-Ni	Nickel			

Gaskets

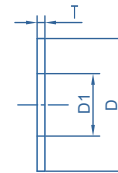

VFS Size in.	Ordering Number	Material	Dimensions, in.(mm)		
			D1	T	D
1/8	VVR-GK-G2	316L	0.09(2.3)	0.028(0.7)	0.26(6.6)
	VVR-GK-G2-Ni	Nickel			
1/4	VVR-GK-G4	316L	0.22 (5.6)	0.028(0.7)	0.47(11.9)
	VVR-GK-G4-Ni	Nickel			
1/2	VVR-GK-G6	316L	0.44(11.2)	0.028(0.7)	0.78(19.8)
	VVR-GK-G6-Ni	Nickel			
3/4	VVR-GK-G8	316L	0.66(16.8)	0.028(0.7)	1.14(29.0)
	VVR-GK-G8-Ni	Nickel			
1	VVR-GK-G16	316L	0.89(22.6)	0.028(0.7)	1.40(35.6)
	VVR-GK-G16-Ni	Nickel			

Face Seal Fittings VVR Series

Male NPT Connectors

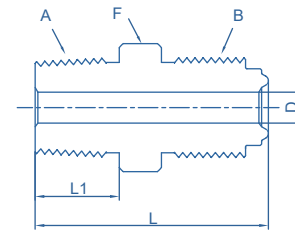

A NPT Size in.	B VFS Size in.	Material	Ordering Number	Dimensions, in.(mm)				Working Pressure psig(bar)	
				L	L1	D	F	Ni	316L
1/8	1/8	316L	VVR-MC2-NT2	1.07(27.2)	0.38	0.09(2.3)	7/16	9000	9000
		316L secondary remelt	VVR-MC2-NT2-SLV		(9.6)			(620)	(620)
1/4	1/4	316L	VVR-MC4-NT2	1.31(33.3)		0.18(4.6)	5/8	10000	6400
		316L secondary remelt	VVR-MC4-NT2-SLV					(689)	(440)
1/4	1/4	316L	VVR-MC4-NT4	1.49 (37.8)		0.18(4.6)	5/8	10000	6400
		316L secondary remelt	VVR-MC4-NT4-SLV		0.56			(689)	(440)
1/2	1/2	316L	VVR-MC8-NT4	1.65(41.9)		0.28(7.1)	15/16	4300	2800
		316L secondary remelt	VVR-MC8-NT4-SLV		(14.2)			(296)	(192)
3/8	1/2	316L	VVR-MC8-NT6	1.65(41.9)	0.56	0.38(9.6)	15/16	4300	2800
		316L secondary remelt	VVR-MC8-NT6-SLV		(14.2)			(296)	(192)
1/2	1/2	316L	VVR-MC8-NT8	1.84(46.7)	0.75	0.4(10.2)	15/16	4300	2800
		316L secondary remelt	VVR-MC8-NT8-SLV		(19.1)			(296)	(192)
3/4	3/4	316L	VVR-MC12-NT12	2.19(55.6)	0.75	0.62(15.7)	1-5/16	3700	2400
		316L secondary remelt	VVR-MC12-NT12-SLV		(19.1)			(254)	(165)

Female NPT Connectors^①

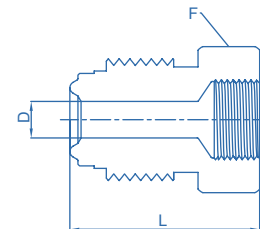

NPT Size in.	VFS Size in.	Material	Ordering Number	Dimensions, in.(mm)			Working Pressure psig(bar)	
				L	D	F flat	Ni	316L
1/16	1/8	316L	VVR-FC2-F1 ^②	1.10(27.9)	0.09(2.3)	7/16	6700	6700
		316L secondary remelt	VVR-FC2-F1-SLV ^②				(461)	(461)
1/8	1/8	316L	VVR-FC2-F2 ^②	1.19(30.2)	0.09(2.3)	9/16	6500	6500
		316L secondary remelt	VVR-FC2-F2-SLV ^②				(447)	(447)
1/4	1/4	316L	VVR-FC4-F2	1.41(35.8)	0.18(4.6)	5/8	8000	8000
		316L secondary remelt	VVR-FC4-F2-SLV				(551)	(551)
1/4	1/4	316L	VVR-FC4-F4	1.54(39.1)	0.18(4.6)	3/4	6600	6600
		316L secondary remelt	VVR-FC4-F4-SLV				(454)	(454)
3/8	1/2	316L	VVR-FC8-F6	1.76(44.7)	0.40(10.2)	15/16	3500	4300
		316L secondary remelt	VVR-FC8-F6-SLV				(241)	(296)
1/2	1/2	316L	VVR-FC8-F8	1.99(50.5)	0.40(10.2)	1-1/16	3500	4300
		316L secondary remelt	VVR-FC8-F8-SLV				(241)	(296)
3/4	3/4	316L	VVR-FC12-F12	2.36(59.9)	0.62(15.7)	1-5/16	3000	3700
		316L secondary remelt	VVR-FC12-F12-SLV				(206)	(254)
1	1	316L	VVR-FC16-F16	2.51(63.8)	0.87(22.1)	1-5/8	2400	3000
		316L secondary remelt	VVR-FC16-F16-SLV				(165)	(206)

① VFS components with fixed threads must remain stationary during installation. These fitting connections should be assembled only to glands with rotating male or female threaded nuts.

② Not designed for gasket retainer assembly

Male Union^①

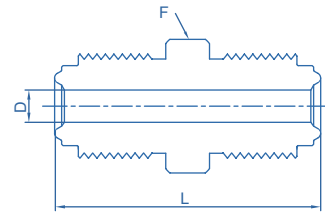

VFS Size in.	Material	Ordering Number	Dimensions in.(mm)			Working Pressure psig(bar)	
			L	D	F	Ni	316L
1/8	316L	VVR-MU2 ^②	1.13(28.7)	0.09(2.3)	3/8	9000(620)	11200(771)
	316L secondary remelt	VVR-MU2-SLV ^②					
1/4	316L	VVR-MU4	1.55(39.4)	0.18(4.6)	5/8	8000(551)	10000(689)
	316L secondary remelt	VVR-MU4-SLV					
1/2	316L	VVR-MU8	1.84(46.7)	0.40(10.2)	15/16	3500(241)	4300(296)
	316L secondary remelt	VVR-MU8-SLV					
3/4	316L	VVR-MU12	2.44(62.0)	0.62(15.7)	1-5/16	3000(206)	3700(254)
	316L secondary remelt	VVR-MU12-SLV					
1	316L	VVR-MU16	2.59(65.8)	0.87(22.1)	1-5/8	2400(165)	3000(206)
	316L secondary remelt	VVR-MU16-SLV					

① VFS components with fixed threads must remain stationary during installation. These fitting connections should be assembled only to glands with rotating male or female threaded nuts.

② Not designed for gasket retainer assembly

Coupling

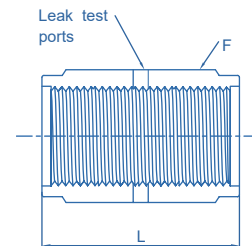

VFS Size in.	Material	Ordering Number	Dimensions in.(mm)	
			L	F
1/8	316L	VVR-FU2	0.66(16.8)	7/16
	316L secondary remelt	VVR-FU2-SLV		
1/4	316L	VVR-FU4	1.19(30.2)	3/4
	316L secondary remelt	VVR-FU4-SLV		
1/2	316L	VVR-FU8	1.31(33.3)	1-1/16
	316L secondary remelt	VVR-FU8-SLV		
3/4	316L	VVR-FU12	1.68(42.7)	1-1/2
	316L secondary remelt	VVR-FU12-SLV		
1	316L	VVR-FU16	2.04(51.8)	1-3/4
	316L secondary remelt	VVR-FU16-SLV		

Face Seal Fittings VVR Series

Male Nut

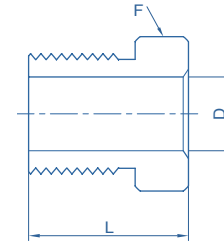

VFS Size in.	Ordering Number	Material	F Hex Flat	Dimensions, in.(mm)	
				L	D
1/8	VVR-MN2	316L	3/8	0.50(12.7)	0.21(5.3)
	VVR-MN2-SLV	316L secondary remelt			
1/4	VVR-MN4	316L	5/8	0.71(18.0)	0.36(9.1)
	VVR-MN4-SLV	316L secondary remelt			
1/2	VVR-MN8	316L	15/16	0.81 (20.6)	0.61(15.5)
	VVR-MN8-SLV	316L secondary remelt			
3/4	VVR-MN12	316L	1-5/16	1.00(25.4)	0.89(22.6)
	VVR-MN12-SLV	316L secondary remelt			
1	VVR-MN16	316L	1-5/8	1.19(30.2)	1.20(30.5)
	VVR-MN16-SLV	316L secondary remelt			

Female Nut

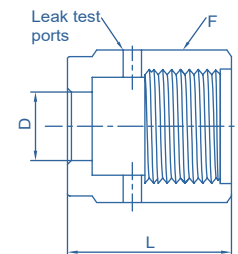

VFS Size in.	Ordering Number	Material	F Hex Flat	Dimensions, in.(mm)	
				L	D
1/8	VVR-FN2	316L	7/16	0.53(13.5)	0.21(5.3)
	VVR-FN2-SLV	316L secondary remelt			
1/4	VVR-FN4	316L	3/4	0.81(20.6)	0.36(9.1)
	VVR-FN4-SLV	316L secondary remelt			
1/2	VVR-FN8	316L	1-1/16	0.88(22.4)	0.61(15.5)
	VVR-FN8-SLV	316L secondary remelt			
3/4	VVR-FN12	316L	1-1/2	1.12(28.4)	0.89(22.6)
	VVR-FN12-SLV	316L secondary remelt			
1	VVR-FN16	316L	1-3/4	1.34(34.0)	1.20(30.5)
	VVR-FN16-SLV	316L secondary remelt			

Face Seal Fittings VVR Series

Cap

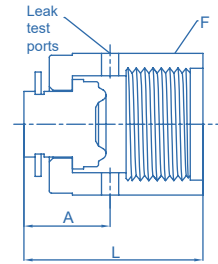

VFS Size in.	Material	Ordering Number	Dimensions, in.(mm)		
			L	A	F Hex Flat
1/8	316L	VVR-C2	0.63(16.0)	0.30(7.6)	7/16
	316L secondary remelt	VVR-C2-SLV			
1/4	316L	VVR-C4	0.94(23.9)	0.44(11.2)	3/4
	316L secondary remelt	VVR-C4-SLV			
1/2	316L	VVR-C8	1.01(25.6)	0.45(11.4)	1-1/16
	316L secondary remelt	VVR-C8-SLV			
3/4	316L	VVR-C12	1.29(32.8)	0.54(13.7)	1-1/2
	316L secondary remelt	VVR-C12-SLV			
1	316L	VVR-C16	1.54(39.1)	0.63(16.0)	1-3/4
	316L secondary remelt	VVR-C16-SLV			

Plug

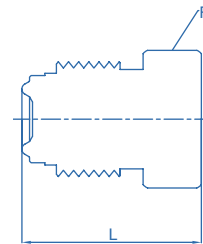

VFS Size in.	Material	Ordering Number	Dimensions, in.(mm)	
			L	F Hex Flat
1/8	316L	VVR-P2 ^①	0.68(17.3)	3/8
	316L secondary remelt	VVR-P2-SLV ^①		
1/4	316L	VVR-P4 ^②	0.92(23.4)	5/8
	316L secondary remelt	VVR-P4-SLV ^②		
1/2	316L	VVR-P8	1.08(27.4)	15/16
	316L secondary remelt	VVR-P8-SLV		
3/4	316L	VVR-P12	1.43(36.3)	1-5/16
	316L secondary remelt	VVR-P12-SLV		

① Not designed for gasket retainer assembly.

② Also available as a rotatable plug.
Ordering number: VVR-P8-R

Micro Weld fittings VMW Series

Reducing union

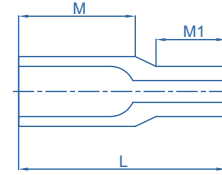

Tube OD	Wall Thickness	Tube OD	Wall Thickness	Ordering Number	Dimensions, in.(mm)			Pressure Rating psig(bar)
					L	M	M1	
1/4	0.035	1/8	0.028	VMW-RU4-2				5100 (351)
3/8	0.035	1/4	0.035	VMW-RU6-4	0.75 (19.0)	0.42 (10.7)	0.25 (6.4)	3300 (227)
1/2	0.049	1/4	0.035	VMW-RU8-4				3700 (254)
		3/8		VMW-RU8-6				3300 (227)

Union Elbow

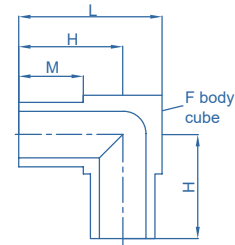

Tube OD	Wall Thickness	Ordering Number	L	Dimensions, in.(mm)			Pressure Rating psig(bar)
				M	F	H	
1/8	0.028	VMW-UE2			5/16	0.41 (10.4)	8500 (585)
1/4	0.035	VMW-UE4	0.56 (14.2)	0.25	5/16	0.41 (10.4)	5100 (351)
3/8	0.035	VMW-UE6	0.69 (17.5)	(6.4)	7/16	0.47 (11.9)	3300 (227)
1/2	0.049	VMW-UE8	0.81 (20.6)		9/16	0.53 (13.5)	3700 (254)

Reducing Union Elbow

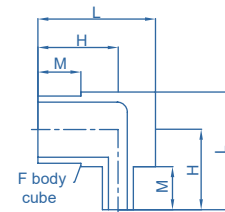

Tube OD	Wall Thickness	Tube OD	Wall Thickness	Ordering Number	Dimensions, in.(mm)				Pressure Rating psig(bar)
					L	M	F	H	
3/8	0.035	1/4	0.035	VMW-RUE6-4	0.69 (17.5)	0.25 (6.4)	7/16	0.47 (11.9)	3300(227)
1/2	0.049	1/4	0.035	VMW-RUE8-4	0.81		9/16	0.53	3700(254)
		3/8		VMW-RUE8-6	(20.6)			(13.5)	3300(227)

Union Tee

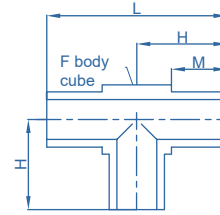

Tube OD	Wall	Ordering Number	Dimensions, in.(mm)				Pressure rating psig(bar)
			L	M	F	H	
1/8	0.028	VMW-UT2	0.82 (20.8)	0.25 (6.4)	5/16	0.41 (10.4)	8500 (585)
1/4	0.035	VMW-UT4			5/16	0.41 (10.4)	5100 (351)
3/8	0.035	VMW-UT6	0.94 (23.9)		7/16	0.47 (11.9)	3300 (227)
1/2	0.049	VMW-UT8	1.06 (26.9)		9/16	0.53 (13.5)	3700 (254)

Reducing Tee

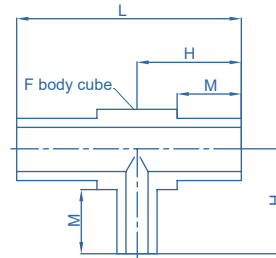

Tube OD	Wall Thickness	Tube OD	Wall Thickness	Ordering Number	Dimensions, in.(mm)				Pressure Rating psig(bar)
					L	M	F	H	
3/8	0.035	1/4	0.035	VMW-RT6-4	0.94(23.9)	0.25 (6.4)	7/16	0.47 (11.9)	3300(227)
1/2	0.049	3/8		VMW-RT8-4	1.06(26.9)		9/16	0.53 (13.5)	3700(254)
				VMW-RT8-6					3300(227)

Cross Union

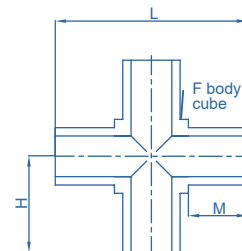

Tube OD	Wall Thickness	Ordering Number	Dimensions, in.(mm)				Pressure Rating psig(bar)
			L	M	F	H	
1/8	0.028	VMW-CU2	0.82 (20.8)	0.25 (6.4)	5/16	0.41 (10.4)	8500 (585)
1/4	0.035	VMW-CU4			5/16	0.41 (10.4)	5100 (351)
3/8	0.035	VMW-CU6	0.94 (23.9)		7/16	0.47 (11.9)	3300 (227)
1/2	0.049	VMW-CU8	1.06 (26.9)		9/16	0.53 (13.5)	3700 (254)

Micro Weld fittings VMW Series

Tribow

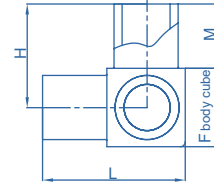

Tube OD	Wall Thickness	Ordering Number	L	Dimensions, in.(mm)			Pressure Rating psig(bar)
				M	F	H	
1/4	0.035	VMW-TB4	0.56(14.2)	0.25 (6.4)	5/16	0.41(10.4)	5100(351)
3/8	0.035	VMW-TB6	0.69(17.5)		7/16	0.47(11.9)	3300(227)
1/2	0.049	VMW-TB8	0.81(20.6)		9/16	0.53(13.5)	3700(254)

Product Features

- Cylinder Connections
- Connect to a cylinder valve
- 1/4NPT male /6mm tube fitting /6mm OD tube connection
- All connections are degrease to oxygen service
- 15 µin. Ra max, 10µin Ra average surface finish

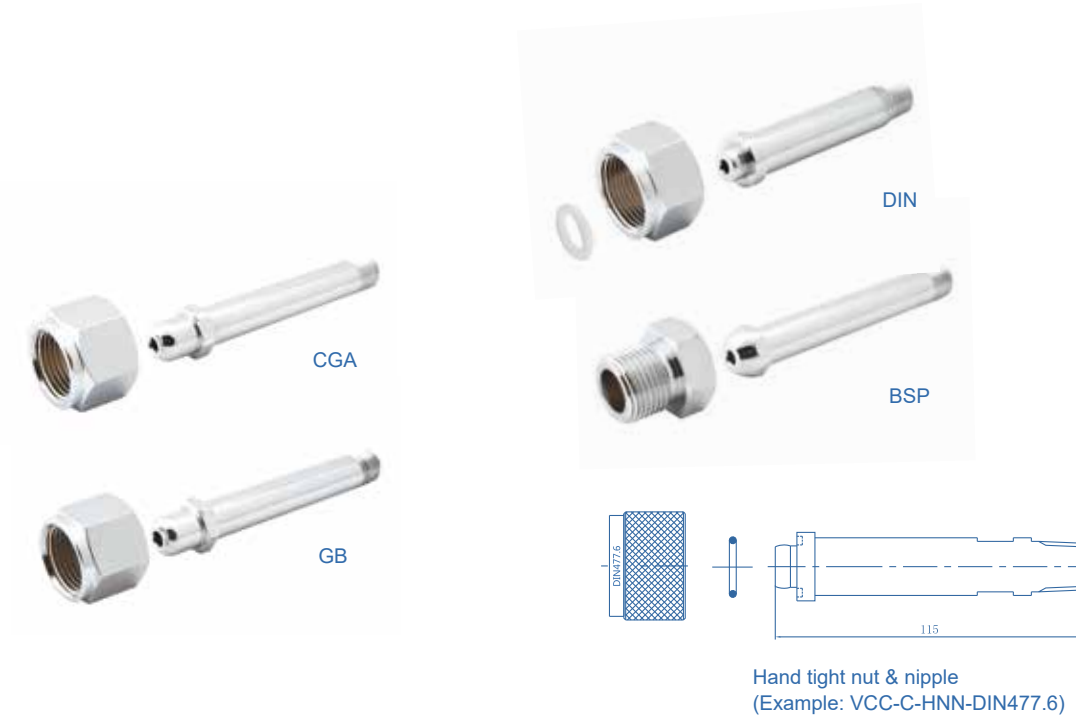

Ordering Information

VUC - S - N - CGA580 - TF6M

Material

S: 316L

Parts

N: nut

NN: nut & nipple

HN: hand tight nut

HNN: hand tight nut & nipple

G: gasket

Inlet Connection

None: 1/4"NPT(M)

6M: 6mm tube fitting

TW6M: 6mm tube weld

TW4: 1/4" tube weld

Cylinder Connection

Detailed description of the cylinder connection including the relevant standard and number of the connection

Cylinder Connections

VUC DISS Series

Technical Data

Materials of Construction	
Wetted	
Nuts	316 Stainless Steel
Nipples	316L Stainless Steel
Outlet Adapters	316L Stainless Steel
Cylinder Valve Outlet Caps	316L Stainless Steel
Gaskets	Nickel Standard*

*Contact factory for other materials available.



Nut, Nipple and Nickel Gasket Assembly

CGA/DISS Number	End Connection	F Hex Flat in.
632 ~ 642	1/4" Tube Weld	1-1/4
	1/2" Tube Weld	
	1/4" Face seal Male	
	1/4" NPT Male	
712 ~ 728	1/4" Tube Weld	1-3/8"
	1/2" Tube Weld	
	1/4" Face seal Male	
	1/4" NPT Male	

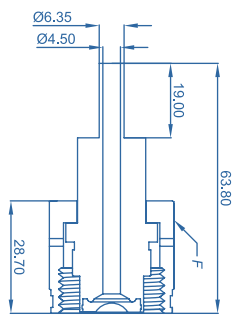

1/4" Tube Weld

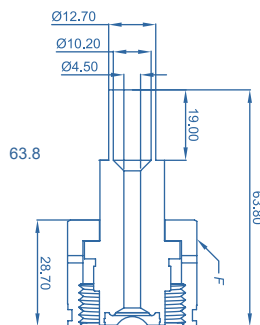

1/2" Tube Weld

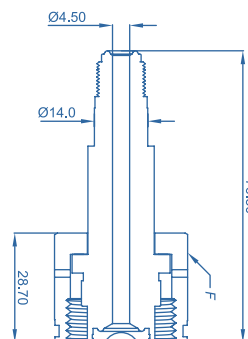

1/4" Face seal male

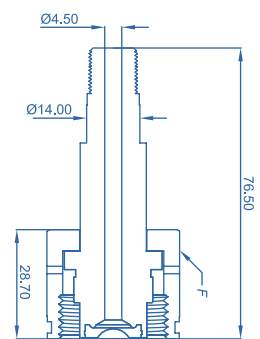

1/4" NPT Male

CAPS

CGA/DISS Number	Ordering Number	Material	F Hex Flat in.	H Length in.	Gas Tight
632 ~ 642	VUC-DISS-C-63	Stainless Steel with	1-1/4	0.98	Yes
712 ~ 728	VUC-DISS-C-71	Nickel gasket	1-3/8		

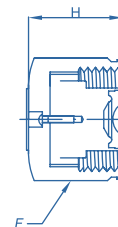

Cylinder Connections VUC DISS Series

GASKETS

Material	Ordering Number	A	H	E
Nickle	VUC-DISS-G-NI	0.56	0.105	0.21
PCTFE	VUC-DISS-G-PC		0.125	

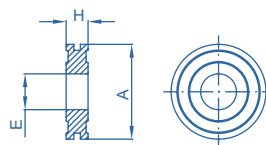

Plugs and Adapters

CGA/DISS Number	Ordering Number	End Connection	H Overall Length	F HexFlat in.
632 ~ 642	VUC-DISS-BP-63	Plug	1.53	1-1/8
	VUC-DISS-A-NT4-63	1/4" NPT Female	1.85	
712 ~ 718	VUC-DISS-BP-71	Plug	1.53	1-1/4
	VUC-DISS-A-NT4-71	1/4" NPT Female	1.85	
720 ~ 728	VUC-DISS-BP-72	Plug	1.53	1-1/4
	VUC-DISS-A-NT4-72	1/4" NPT Female	1.85	

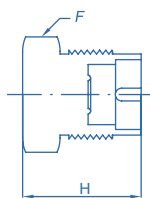

Plug

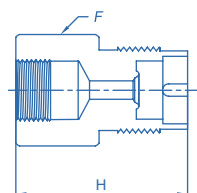

Adaptor

Ordering Information

VUC-DISS- NNG - CGA632 - TW4 - Ni

Parts Code

N: nut

P: nipple

NNG: nut,nipple,gasket

CGA Number

CGA632 CGA642 CGA720

CGA634 CGA712 CGA722

CGA636 CGA714 CGA724

CGA638 CGA716 CGA726

CGA640 CGA718 CGA728

Gasket Material

Ni: Nickle

PC: PCTFE

End Connection

MV4: 1/4" face seal male

TW4: 1/4" tube weld

TW8: 1/2" tube weld

M4: 1/4" NPT Male

* Other connection standard,consult factory

Pressure Gauge

VGU/VRU/VGT/VRT/VG/VR Series

Product Feature

- UHP "clean" for semiconductor gas applications, in accordance with SEMI/SEMATECH
- Packaged in two bags
- Purged with nitrogen
- Protective cap over threaded connection
- 100 % factory calibrated and helium leak tested to a maximum rate of 1×10^{-9} std cm³/s

Technical Data

Type	pressure gauge
Materials:	
End connection	316L VAR,electropolished
Bourdon tube	316L SS
Case	304 SS
Lens	polycarbonate
Movement	stainless steel
Dial & Pointer	aluminum
Scale	psig/bar dual scale
Dial size	2"
Accuracy	±2%
Ambient temperature	-40°F to 140°F (-40°C to 60°C)



VRU

VGU



VRT

VGT



VR

VG

Dimensions

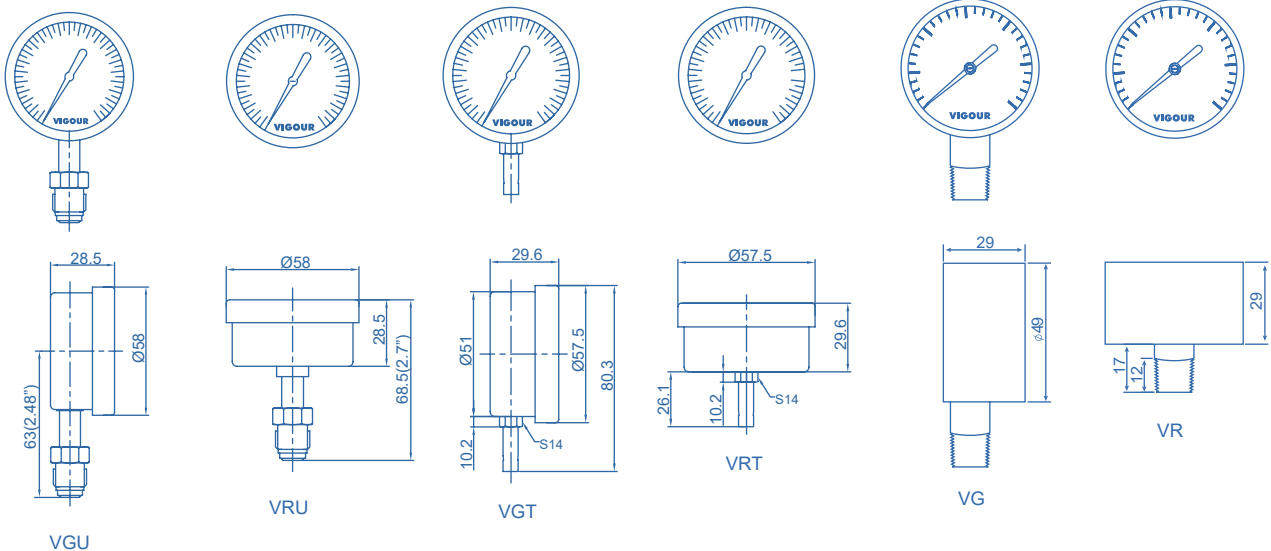

Ultra High Purity Gauge VGU/VRU/VGT/VRT/VG/VR Series

Ordering Information

VGU/VRU Series (Ultra High Purity)

Ordering Number	Inlet Connection	Pressure Range(bar/psig)
VGU Series, Lower Mount, VFS End		
VGU20S-1.6/2.5/4/6/10/16/25/35/60B-FV4	1/4"face seal female	0~1.6/2.5/4/6/10/16/25/35/60 bar 0~23/30/60/86/140/230/350/500/860 psig
VGU20S-1.6/2.5/4/6/10/16/25/35/60B-MV4	1/4"face seal male	
VGU20S-1.6/2.5/4/6/10/16/25/35/60B-RMV4	1/4"rotatable face seal male	
VGU20S-100/150/250/315/400B-FV4	1/4"face seal female	0~100/150/250/315/400 bar 0~1500/2000/3500/4500/5800 psig
VGU20S-100/150/250/315/400B-MV4	1/4"face seal male	
VGU20S-100/150/250/315/400B-RMV4	1/4"rotatable face seal male	
VGU20S-V1.6/V2.5/V4/V6/V10/V16B-FV4	1/4"face seal female	Vac~1.6/2.5/4/6/10/16 bar Vac~23/30/60/86/140/230 psig
VGU20S-V1.6/V2.5/V4/V6/V10/V16B-MV4	1/4"face seal male	
VGU20S-V1.6/V2.5/V4/V6/V10/V16B-RMV4	1/4"rotatable face seal male	
VRU Series, Center-Back Mount, VFS End		
VRU20S-1.6/2.5/4/6/10/16/25/35/60B-FV4	1/4"face seal female	0~1.6/2.5/4/6/10/16/25/35/60 bar 0~23/30/60/86/140/230/350/500/860 psig
VRU20S-1.6/2.5/4/6/10/16/25/35/60B-MV4	1/4"face seal male	
VRU20S-1.6/2.5/4/6/10/16/25/35/60B-RMV4	1/4"rotatable face seal male	
VRU20S-100/150/250/315/400B-FV4	1/4"face seal female	0~100/150/250/315/400 bar 0~1500/2000/3500/4500/5800 psig
VRU20S-100/150/250/315/400B-MV4	1/4"face seal male	
VRU20S-100/150/250/315/400B-RMV4	1/4"rotatable face seal male	
VRU20S-V1.6/V2.5/V4/V6/V10/V16B-FV4	1/4"face seal female	Vac~1.6/2.5/4/6/10/16 bar Vac~23/30/60/86/140/230 psig
VRU20S-V1.6/V2.5/V4/V6/V10/V16B-MV4	1/4"face seal male	
VRU20S-V1.6/V2.5/V4/V6/V10/V16B-RMV4	1/4"rotatable face seal male	

VGT/VRT Series(Tube Connection)

Ordering Number	Inlet Connection	Pressure Range(bar/psig)
VGT Series, Lower Mount, Tube End		
VGT20S-1.6/2.5/4/6/10/16/25/35/60B-T4	1/4"tube	0~1.6/2.5/4/6/10/16/25/35/60 bar 0~23/30/60/86/140/230/350/500/860 psig
VGT20S-1.6/2.5/4/6/10/16/25/35/60B-T6M	6mm tube	
VGT20S-100/150/250/315/400B-T4	1/4"tube	
VGT20S-100/150/250/315/400B-T6M	6mm tube	0~100/150/250/315/400 bar 0~1500/2000/3500/4500/5800 psig
VGT20S-V2.5/V4/V16B-T4	1/4"tube	
VGT20S-V2.5/V4/V16B-T6M	6mm tube	
VRT Series, Center-Back Mount, Tube End		
VRT20S-1.6/2.5/4/6/10/16/25/35/60B-T4	1/4"tube	0~1.6/2.5/4/6/10/16/25/35/60 bar 0~23/30/60/86/140/230/350/500/860 psig
VRT20S-1.6/2.5/4/6/10/16/25/35/60B-T6M	6mm tube	
VRT20S-100/150/250/315/400B-T4	1/4"tube	
VRT20S-100/150/250/315/400B-T6M	6mm tube	0~100/150/250/315/400 bar 0~1500/2000/3500/4500/5800 psig
VRT20S-V1.6/V2.5/V4/V6/V10/V16B-T4	1/4"tube	
VRT20S-V1.6/V2.5/V4/V6/V10/V16B-T6M	6mm tube	

VG/VR Series(NPT Connection)

Ordering Number	Inlet Connection	Pressure Range(bar/psig)
VG Series, Lower Mount, NPT End		
VG20S-1.6/2.5/4/6/10/16/25/35/60B-M4	1/4"male NPT	0~1.6/2.5/4/6/10/16/25/35/60 bar 0~23/30/60/86/140/230/350/500/860 psig
VG20S-100/150/250/315/400B-M4	1/4"male NPT	
VG20S-V1.6/V2.5/V4/V6/V10/V16B-M4	1/4"male NPT	
VR Series, Center-Back Mount, Tube End		
VR20S-1.6/2.5/4/6/10/16/25/35/60B-M4	1/4"male NPT	0~1.6/2.5/4/6/10/16/25/35/60 bar 0~23/30/60/86/140/230/350/500/860 psig
VR20S-100/150/250/315/400B-M4	1/4"male NPT	
VR20S-V1.6/V2.5/V4/V6/V10/V16B-M4	1/4"male NPT	

Elgiloy® is registered trademark of Elgiloy Specialty Metals.
Hastelloy® is registered trademark of Haynes International, Inc.
Viton® and Kalrez® are registered trademarks of Dupont.



Wir bieten Lösungen für Ihre Ideen!

We offer solutions regarding your ideas!

Wir bieten Lösungen für Ihre Ideen!
We offer solutions regarding your ideas!